CORPORATE INFORMATION

Secretary and registered office

Selwyn Noik, CA(SA)
Investec Group Limited
2nd Floor
100 Grayston Drive
Sandown
Sandton, 2196
(PO Box 785700, Sandton, 2146)

South African law advisers

Jowell Glyn & Marais Inc.
(Registration number 1990/000849/21)
Jowell Glyn & Marais House
72 Grayston Drive
Sandown
Sandton, 2196
(PO Box 652361, Benmore, 2010)

Lead sponsor in South Africa

Ernst & Young Sponsors (Proprietary) Limited
(Registration number 2000/031843/07)
In association with Jowell Glyn & Marais Inc.
2nd Floor
Ernst & Young House
Wanderers Office Park
52 Corlett Drive
Illovo, 2196
(PO Box 2322, Johannesburg, 2000)

Sponsoring broker in Botswana

Motswedi Securities (Proprietary) Limited
(Registration number 2002/28)
2nd Floor
United Nations Building
Plot 22
Khama Crescent
Gaborone, Botswana
(PO Box 41015, Gabarone, Botswana)

Transfer secretaries in South Africa

Computershare Investor Services Limited
(Registration number 1958/003546/06)
2nd Floor
Edura
41 Fox Street
Johannesburg, 2001
(PO Box 61051, Marshalltown, 2107)

Transfer secretaries in the United Kingdom

Computershare Investor Services PLC
PO Box 82
The Pavilions
Bridgwater Road
Bristol BS99 7NH
United Kingdom
(PO Box 82, The Pavilions, Bridgwater Road, BS99 7NH, England)

Merchant bank

Investec Bank Limited
(Registration number 1969/004763/06)
2nd Floor
100 Grayston Drive
Sandown
Sandton, 2196
(PO Box 785700, Sandton, 2146)

English law advisers

Linklaters
One Silk Street
London EC2Y 8HQ
United Kingdom

Joint sponsor in South Africa

Investec Securities Limited
(Registration number 1972/008905/06)
3rd Floor
100 Grayston Drive
Sandown
Sandton, 2196
(PO Box 785700, Sandton, 2146)

Sponsoring broker in Namibia

HSBC Securities (Namibia) (Proprietary) Limited
(Registration number 95/505)
4th Floor
Sanlam Centre
154 Independence Avenue
Windhoek, Namibia
(PO Box 1272, Windhoek, Namibia)

Reporting accountants and auditors

Ernst & Young
(Chartered Accountants (SA))
Ernst & Young House
Wanderers Office Park
52 Corlett Drive
Illovo, 2196
(PO Box 2322, Johannesburg, 2000)

Transfer secretaries in Namibia

The Transfer Secretaries (Proprietary) Limited
(Registration number 93/713)
Shop 12, Kaiserkrone Centre
Post Street Mall
Windhoek, Namibia
(PO Box 2401, Windhoek, Namibia)

LETTER FROM YOUR CHAIRMAN

20 June 2002

Dear Shareholder,

Over ten years ago, Investec recognised that the opening of South Africa to foreign banking institutions was inevitable and that if Investec was to maintain its position in the domestic market and to grow, it would have to internationalise its operations.

From that time, Investec's mission was to be one of the world's great specialist banking institutions and it adopted a strategy of establishing itself in significant banking centres abroad. There, Investec would be exposed to the latest thinking and products and would be able to raise capital to improve the competitive positioning of both its South African and its foreign operations. Central to achieving this objective, once Investec had reached critical mass in London, was to obtain a listing on the London Stock Exchange.

In November last year, Investec announced that it had obtained permission from the Minister of Finance and the South African Reserve Bank to establish a "Dual Listed Companies" Structure with linked companies listed in London and Johannesburg. The circular to members of Investec Holdings Limited ("**Inhold**") and Investec Group Limited ("**IGL**"), which accompanies this letter, invites members to pass the resolutions that are necessary to achieve that aim. The Inhold pyramid structure is clearly not appropriate to the changed circumstances and it is intended that Inhold will unbundle the IGL shares it holds and then be wound up.

Since Dual Listed Companies Structures are not all that well-known in the South African market, I thought that an informal word of explanation might help.

IGL will retain all its businesses in continental Southern Africa and Mauritius and its primary listing on the JSE. Most of its other businesses will be placed into a United Kingdom company, Investec PLC, which is presently a wholly owned subsidiary of IGL. Investec PLC will then be unbundled from IGL and listed on the London Stock Exchange with a secondary listing on the JSE.

The purpose of the Dual Listed Companies Structure is to knit IGL and Investec PLC back together again as a single economic enterprise. This is achieved by a number of agreements and mechanisms, principally a Sharing Agreement between IGL and Investec PLC. The agreements are designed to ensure, insofar as possible, that the economic and, therefore, market value, of a share in one company will be the same as the economic and market value of a share in the other.

Perhaps the easiest way to conceptualise the structure is to think of a single economic "pot" in which each share, irrespective of the company that issued it, is intended to confer the same dividends and right to capital of the pot and the same right to vote in respect of its future.

The concept behind the structure is really as simple as that. The complexities are legal niceties intended to ensure that the structure is properly entrenched under two different legal systems and that the intended equity is maintained in the face of likely (and even some relatively unlikely) future scenarios or, to the extent that equity cannot be fully achieved, to compensate for any measurable inequity that may be introduced.

Thus, under the structure, if one company fares better than the other, there are equalisation mechanisms to ensure that the shareholders of both companies are paid the same dividends. If one company makes a bad decision (or a good one for that matter), the loss (or profit) to the shareholders of both will be the same. If one of the companies becomes insolvent, because there are no cross guarantees, the other company need not also become insolvent and the shareholders of the insolvent company are compensated by getting shares in the other (solvent) company. All shares vote (where there is no conflict of interest) as if they were part of a single common class of ordinary shares. Where conflicts of interest may arise, the shareholders of the company that could be prejudiced have, in effect, a veto.

The intention of this structure is that a shareholder should generally (i.e. aside from certain considerations such as personal tax) be indifferent to which of the companies' shares he or she holds.

To underline the point and facilitate the market's operation, we have arranged the mechanics of the IGL unbundling so that for every 100 IGL shares you hold, you will, after all is said and done, hold 37 IGL ordinary shares and 63 Investec PLC ordinary shares, i.e. 100 instruments. Market conditions aside, each of those instruments should have the same market value as each of the others and the same market value as an original IGL share. In practice, differentials will arise, but we would expect the markets to arbitrage out most of these differentials.

South African residents will be able to hold shares in Investec PLC on its South African branch register. UK residents can hold shares in Investec PLC on its principal register in the UK.

I believe the above should equip you with a conceptual understanding of the structure and so make the circular easier to read and understand. Some more details of the structure are given in paragraph 3 of the enclosed circular and a much fuller summary is to be found in Annexure I to the circular. By definition, summaries leave things out and contractual arrangements of the nature described in this letter can only really be understood in all their detail by reading the contracts themselves. These contracts lie for inspection at the place and time referred to in the circular.

We at Investec are very excited by the development, which is recommended by the directors and, as the circular tells you, the directors intend to vote their shareholdings in favour of the resolutions. If you are at all confused, or do not know how you should vote or what you need to do, you should consult your stockbroker, auditor, bank manager, attorney or other adviser.

Yours sincerely

A handwritten signature in black ink, appearing to read 'Hugh Herman', with a stylized, cursive script.

Hugh Herman

Chairman

CONTENTS

	<i>Page</i>
Corporate information	1
Letter from your Chairman	2
Salient dates and times	6
Salient features	8
Circular to Inhold members and IGL members	
1. Introduction	14
2. Rationale	15
3. Outline of the DLC Structure	15
4. Procedure for the implementation of the DLC Structure	18
5. Financial information relating to Inhold	25
6. Financial information relating to IGL	26
7. Taxation considerations	29
8. Exchange Control considerations	31
9. Procedure for the surrender of Inhold share certificates and IGL share certificates	35
10. Suspensive conditions	37
11. Listings	37
12. Major shareholders of Inhold and IGL	37
13. Inhold directors' interests	38
14. IGL directors and directors' interests	38
15. Litigation statement	41
16. Experts' consents	41
17. Opinion and recommendation	41
18. Notices of general meetings	41
19. Directors' responsibility statement	42
20. Documents available for inspection	42
Annexure I Details of the DLC Structure	43
Annexure II Historic financial information relating to Inhold	67
Annexure III Published audited results of Inhold for the year ended 31 March 2002	71
Annexure IV Pro forma financial information relating to Inhold	72
Annexure V Reporting accountants' report on the pro forma financial information relating to Inhold	74
Annexure VI Historic financial information relating to IGL	76
Annexure VII Published audited results of IGL for the year ended 31 March 2002	84
Annexure VIII Pro forma financial information relating to IGL and Investec PLC	86

Annexure IX	Reporting accountants' report on the pro forma financial information relating to IGL and Investec PLC	89
Annexure X	Trading history of Inhold ordinary shares on the JSE	91
Annexure XI	Table of entitlement of Inhold members in terms of the Inhold unbundling	92
Annexure XII	Trading history of IGL ordinary shares on the JSE	94
Annexure XIII	Table of entitlement of IGL members in terms of the IGL capital restructure and the IGL unbundling	95
Annexure XIV	Extracts from the IGL Articles	96
Annexure XV	Continuing rights under the IGL employee ownership schemes, the adoption of the IGL 2002 scheme and salient features of the Investec PLC employee share plans and the Investec PLC employee trusts	104
Annexure XVI	Terms and conditions of shares held in the nominee	116
Annexure XVII	Terms and conditions of the custody agreement	121
Annexure XVIII	Service and settlement fees of Computershare Custodial Services Limited for members	127
Definitions		128
Notice of general meeting of Inhold members		136
Form of proxy for the general meeting of Inhold members (blue)		Attached
Notice of general meeting of IGL members		143
Form of proxy for the general meeting of IGL members (yellow)		Attached
Form of surrender for use by certificated Inhold members only (pink)		Attached
Form of surrender for use by certificated IGL members only (green)		Attached

SALIENT DATES AND TIMES

2002

Last day for submission of forms of proxy by not later than 09:00 in the case of Inhold members or 09:30 in the case of IGL members	Thursday, 11 July
Last day to dematerialise or rematerialise Inhold ordinary shares prior to the Inhold unbundling (17:00)	Thursday, 11 July
Inhold general meeting at 09:00	Friday, 12 July
IGL general meeting at 09:30, or as soon thereafter as the Inhold general meeting is concluded	Friday, 12 July
Results of the Inhold general meeting and the IGL general meeting announced on SENS	Friday, 12 July
Last day to dematerialise or rematerialise IGL ordinary shares prior to the IGL unbundling (17:00)	Friday, 12 July
Results of the Inhold general meeting and the IGL general meeting published in the press	Monday, 15 July
Last day to trade Inhold ordinary shares to participate in the Inhold unbundling (17:00)	Thursday, 18 July
Effective date of the Inhold unbundling after the close of business (17:00)	Thursday, 18 July
Inhold ordinary shares suspended on the JSE from the commencement of business (09:00)	Friday, 19 July
Last day to trade IGL ordinary shares (including IGL ordinary shares distributed pursuant to the Inhold unbundling) to participate in, <i>inter alia</i> , the IGL capital restructure and the IGL unbundling (17:00)	Friday, 19 July
Effective date of the IGL capital restructure and the IGL unbundling after the close of business (17:00)	Friday, 19 July
IGL ordinary shares trade ex-entitlement (to participate in the IGL capital restructure and the IGL unbundling) from the commencement of business (09:00)	Monday, 22 July
Secondary listing of Investec PLC ordinary shares in the Financials – “Speciality & Other Finance” sector of the JSE lists at the commencement of business (09:00) and commencement of conditional trading in the new Investec PLC ordinary shares to be issued pursuant to the Investec PLC capital raising will commence at the commencement of business (08:00 London time) on the London Stock Exchange	Monday, 22 July
Record date to participate in the Inhold unbundling (17:00)	Thursday, 25 July
Dematerialised Inhold members will have their safe custody accounts that they hold with their CSDP or broker updated in respect of their entitlement to IGL ordinary shares arising from the Inhold unbundling	Friday, 26 July
Listing of Inhold ordinary shares terminated on the JSE from the commencement of business (09:00)	Friday, 26 July
Record date to participate in, <i>inter alia</i> , the IGL capital restructure and the IGL unbundling (17:00)	Friday, 26 July
Admission of Investec PLC ordinary shares to the UKLA’s Official List and admission to trading on the London Stock Exchange in the “Speciality & Other Finance” sector at the commencement of business at (08:00 London time)	Monday, 29 July
Listing of new Investec PLC ordinary shares, issued pursuant to the Investec PLC capital raising on the JSE from the commencement of business (09:00)	Monday, 29 July
Final Offering Circular in respect of the admission of Investec PLC’s ordinary shares to the UKLA’s Official List and admission to trading on the London Stock Exchange will be posted to IGL members recorded in the register of IGL members as such at the close of business (17:00) on Friday, 26 July 2002	Monday, 29 July

New Investec PLC share certificates and new IGL share certificates in respect of the Inhold unbundling, the IGL capital restructure, the IGL name change and the IGL unbundling posted to certificated Inhold members and certificated IGL members who surrender their documents of title by the close of business on the record date for the Inhold unbundling or the record date for the IGL unbundling, as the case may be, or, failing such surrender, within five business days of surrender	Monday, 29 July
Dematerialised IGL members (and dematerialised Inhold members who become dematerialised IGL members pursuant to the Inhold unbundling) will have their safe custody account that they hold with their CSDP or broker updated in respect of the IGL capital restructure, the IGL name change and the IGL unbundling	Monday, 29 July

Notes:

1. The above dates and times are subject to amendment. Any amendment will be announced on SENS and in the press.
2. All references to time in this circular are South African time unless otherwise stated.
3. The definitions commencing on page 128 of this circular apply, *mutatis mutandis*, to this information on salient dates and times.
4. No dematerialisation or rematerialisation of Inhold ordinary shares will take place after Thursday, 11 July 2002 and, accordingly, Inhold members are advised that in order to trade their entitlement to the IGL ordinary shares on the last day to trade for the IGL capital restructure and the IGL unbundling, being Friday, 19 July 2002, their existing Inhold ordinary shares will need to be dematerialised prior to the close of business on Thursday, 11 July 2002.
5. No dematerialisation or rematerialisation of IGL ordinary shares existing prior to the IGL capital restructure will take place after Friday, 12 July 2002. Dematerialisation and rematerialisation of IGL ordinary shares resulting from the IGL capital restructure can only take place from Monday, 29 July 2002.
6. All dealings in the new Investec PLC ordinary shares between commencement of conditional dealing on the London Stock Exchange and unconditional dealing on the London Stock Exchange will be on a "when issued" basis. If listing by the UKLA and admission to trading does not become effective, all such dealings would be of no effect and any such deal would be at the sole risk of the parties concerned.

SALIENT FEATURES

This salient features section provides an outline of the transactions detailed in this circular and details of the separate general meetings of Inhold members and IGL members. This circular should be read in its entirety for a full appreciation of the transactions and the actions required by Inhold members and IGL members. The definitions commencing on page 128 of this circular are also applicable to these salient features.

I. INTRODUCTION

It was announced on 22 November 2001 that IGL would pursue a listing on both the London Stock Exchange and the JSE using a DLC Structure. Further, it has been decided that as part of the implementation of the DLC Structure, Inhold will unbundle its holding of IGL ordinary shares, delist from the JSE and be wound-up by way of a members' voluntary winding-up. A summary of the transactions proposed to implement the DLC Structure is outlined in paragraph 2 of these salient features below.

2. THE TRANSACTIONS

In order to implement the DLC Structure, the directors of Inhold and the directors of IGL propose, subject to the fulfillment of the suspensive conditions, that the following transactions be implemented:

2.1 The Inhold reorganisation

(i) *The conversion of the IGL convertible preference shares*

Inhold holds 2 000 000 IGL convertible preference shares. The IGL convertible preference shares are convertible into IGL ordinary shares on a 1 for 1 basis. Inhold agreed to the early conversion of the IGL convertible preference shares with effect from 18 June 2002 in consideration for the receipt of R35 million from IGL to compensate for the present value of the lower dividend that Inhold is expected to receive by holding IGL ordinary shares earlier than envisaged by the conversion terms. The terms of the IGL convertible preference shares will be amended to allow for their early conversion by the adoption of IGL Articles referred to in paragraph 2.5 of these salient features.

(ii) *Cancellation of certain agreements between Inhold and Fintique II and Fintique III*

Inhold was a party to an agreement with Fintique II which it agreed to cancel in return for which it received compensation of 75 000 IGL ordinary shares from Fintique II.

Inhold was also a party to an agreement with Fintique III. Inhold agreed to the cancellation of this agreement in return for which it received compensation of 120 000 IGL ordinary shares from Fintique III.

(iii) *Sale by Inhold of IGL ordinary shares, settlement of outstanding liabilities and redemption of cumulative redeemable preference shares in Inhold*

Inhold sold 2 985 176 of its IGL ordinary shares between 10 June 2002 and 12 June 2002 thereby raising R505 million. This, together with the settlement it received in (i) above, has enabled Inhold to redeem its outstanding cumulative redeemable preference shares at par and settle other liabilities, subsequent to which its only remaining liability will be unclaimed dividends, which will be transferred into a trust for the benefit of the relevant shareholders.

The pro forma financial effects of the Inhold reorganisation are included in the pro forma financial information relating to Inhold in Annexure IV to this circular.

2.2 The Inhold unbundling, the Inhold delisting and the Inhold winding-up

After giving effect to the Inhold reorganisation in 2.1 above, Inhold will have no liabilities and its only asset will be its shareholding in IGL, which will be unbundled to Inhold members.

In terms of the Inhold unbundling, Inhold will distribute its entire shareholding in IGL to Inhold members registered as such on the record date for the Inhold unbundling, in the ratio of 86.04 IGL ordinary shares for every 100 Inhold ordinary shares held, by way of a dividend *in specie* and a reduction of share capital and share premium.

A table of entitlement to IGL ordinary shares to which an Inhold member is entitled in terms of the Inhold unbundling where the number of Inhold ordinary shares held on the record date for the Inhold unbundling is not a multiple of 100, is set out in Annexure XI to this circular. It should be noted that an Inhold member's entitlement to IGL ordinary shares in terms of the abovementioned ratio will be rounded down to the nearest whole number if any fraction resulting is less than 0.5 or rounded up to the nearest whole number if any fraction resulting is equal to or greater than 0.5.

The pro forma financial effects of the Inhold unbundling and the pro forma financial information relating to Inhold are included in Annexure IV to this circular.

Subsequent to the Inhold unbundling, Inhold will have no assets or liabilities and, accordingly, an application will be made to the JSE for the suspension of the listing of Inhold with effect from the commencement of business on Friday, 19 July 2002 and the delisting of Inhold from the JSE with effect from the commencement of business on Friday, 26 July 2002, subsequent to which it is proposed that Inhold will be wound-up by way of a members' voluntary winding-up.

Inhold members who **do not trade** their entitlement to IGL ordinary shares received in terms of the Inhold unbundling on Friday, 19 July 2002 (being the last day to trade in IGL ordinary shares in order to participate in the IGL capital restructure and the IGL unbundling), will **automatically participate** in the IGL capital restructure and the IGL unbundling referred to in paragraphs 2.6 and 2.7 of these salient features below.

An Inhold member who participates in the IGL capital restructure and the IGL unbundling will, for each 100 IGL ordinary shares to which he is entitled in terms of the Inhold unbundling, **instead** receive 37 IGL ordinary shares and 63 Investec PLC ordinary shares in terms of the IGL capital restructure and the IGL unbundling.

A table of entitlement to IGL ordinary shares and Investec PLC ordinary shares to which an Inhold member who participates in the IGL capital restructure and the IGL unbundling is entitled, where the number of IGL ordinary shares received in terms of the Inhold unbundling is not a multiple of 100, is set out in Annexure XI to this circular.

2.3 The IGL reorganisation

(i) *The conversion of the IGL convertible preference shares*

IGL has agreed to accelerate the conversion of 2 000 000 IGL convertible preference shares held by Inhold by way of an issue of 2 000 000 IGL ordinary shares to Inhold, by way of an issue of 2 000 000 IGL ordinary shares to Inhold together with a payment of R35 million, with effect from 18 June 2002. The terms of the IGL convertible preference shares will be amended to allow for their early conversion by the adoption of IGL Articles referred to in paragraph 2.5 of these salient features;

(ii) *Cancellation of agreement with Inhold*

IGL has agreed to the cancellation of an agreement with Inhold in terms of which IGL acquired and agreed that on 31 July 2008 it will take delivery of 3 573 994 Investec Bank shares from Inhold in exchange for the issue of 3 573 994 IGL ordinary shares. Inhold had acquired the shares in question from Fintique II and has agreed to cancel that agreement. IGL will, on 31 July 2008, take delivery of the 3 573 994 Investec Bank shares against delivery of 3 573 994 IGL ordinary shares; and

(iii) *Acquisition of compulsorily convertible debentures issued by Investec Bank from Fintique III*

IGL entered into an agreement with Fintique III to accelerate the implementation of certain existing agreements which would have taken place in December 2004. Accordingly, with effect from 18 June, 2002, IGL acquired the right to receive the redemption proceeds and the obligation to subscribe for Investec Bank ordinary shares in respect of 9 500 000 compulsorily convertible debentures issued by Investec Bank for a total consideration of R1 656 million which was settled by the issue of 9 500 000 IGL ordinary shares. Fintique III has agreed to waive its right to receive ordinary dividends until:

- 15 December 2004 (the original date for implementation) in respect of 7 500 000 of these IGL ordinary shares and has undertaken not to dispose of these IGL ordinary shares before that date; and
- 31 March 2008 in respect of 2 000 000 of these IGL ordinary shares and has undertaken not to dispose of these IGL ordinary shares before that date. The IGL share scheme has agreed that on 15 December 2004 it will acquire these 2 000 000 IGL ordinary shares and has undertaken to waive its right to receive ordinary dividends until 31 March 2008 and not to dispose of these shares until that date, in exchange for the delivery to Fintique III of 2 000 000 IGL ordinary shares which are not subject to any restrictions.

The pro forma financial effects of the IGL reorganisation are included in the pro forma financial information relating to IGL and Investec PLC in Annexure VIII to this circular.

2.4 The IGL internal restructure

In order to implement the DLC Structure, IGL will transfer the PLC operations to Investec PLC or subsidiaries of Investec PLC. The effect will be that all the PLC operations will be held by Investec PLC or its subsidiaries with the balance of the existing operations still being held by IGL or its subsidiaries. Investec PLC is currently a wholly owned subsidiary of IGL.

The subsidiaries being transferred in terms of the IGL internal restructure and the intermediary holding companies are wholly-owned subsidiaries of IGL. Accordingly, the IGL internal restructure will have no effect on the earnings, headline earnings, net asset value or tangible net asset value per IGL ordinary share for the year ended 31 March 2002 or at 31 March 2002, as the case may be.

2.5 Adoption of a memorandum and new articles of association by IGL

Certain of the provisions of the DLC Agreements will be reflected in the IGL Memorandum and Articles. For convenience of administration, IGL's Memorandum and Articles will be aligned, insofar as the laws of their respective jurisdictions permit, with those of Investec PLC. The IGL Board proposes to adopt new memorandum and articles of association to accomplish this and to incorporate the various amendments to the Act and the Listings Requirements which have come into force over the past few years.

2.6 The IGL capital restructure

The IGL capital restructure is designed to result in an IGL member who holds 100 IGL ordinary shares before the IGL capital restructure referred to in this paragraph and the IGL unbundling referred to in paragraph 2.7 below, holding 100 instruments of equivalent value – 37 IGL ordinary shares and 63 Investec PLC ordinary shares – after those transactions have been implemented. To achieve this, IGL will restructure its share capital, in terms of which:

- (i) the par value of the ordinary shares in the authorised and issued share capital of IGL will be reduced from R0.60 each to R0.001 each; and
- (ii) each 100 ordinary shares in the authorised and issued share capital of IGL will be reduced to 37 ordinary shares.

A table of entitlement to IGL ordinary shares to which an IGL member is entitled after the IGL capital restructure where the number of IGL ordinary shares held on the record date for the IGL capital restructure is not a multiple of 100 is set out Annexure XIII to this circular. It should be noted that an IGL member's entitlement to IGL ordinary shares in terms of the IGL capital restructure will be rounded down to the nearest whole number if any fraction resulting is less than 0.5 or rounded up to the nearest whole number if any fraction resulting is equal to or greater than 0.5.

2.7 The IGL unbundling

Subject to the fulfillment of the suspensive conditions and subsequent to the IGL capital restructure, IGL will distribute its entire shareholding of Investec PLC ordinary shares to IGL members registered as such on the record date for the IGL unbundling in the ratio of 63 Investec PLC ordinary shares for every 100 IGL ordinary shares held before the IGL capital restructure, by way of a dividend *in specie* and a reduction of share capital and share premium.

A table of entitlement to Investec PLC ordinary shares to which an IGL member is entitled where the number of IGL ordinary shares held on the record date for the IGL unbundling is not a multiple of 100 is set out in Annexure XIII to this circular. It should be noted that an IGL member's entitlement to Investec PLC ordinary shares in terms of the abovementioned ratio will be rounded down to the nearest whole number if any fraction resulting is less than 0.5 or rounded up to the nearest whole number if any fraction resulting is equal to or greater than 0.5.

2.8 The financial effects of the IGL capital restructure and the IGL unbundling

The combined effect of the IGL capital restructure and the IGL unbundling will be that the number of IGL ordinary shares held by an IGL member before the IGL capital restructure and the IGL unbundling will equal the aggregate number of IGL ordinary shares and Investec PLC ordinary shares held by that IGL member after the IGL capital restructure and the IGL unbundling, i.e. for every 100 IGL ordinary shares held before the IGL capital restructure and the IGL unbundling, an IGL member will, after the IGL capital restructure and IGL unbundling, hold 37 IGL ordinary shares and 63 Investec PLC ordinary shares, being 100 shares in the aggregate.

The IGL ordinary shares and the Investec PLC ordinary shares have identical economic rights and, market conditions aside, each of those shares should have the same market value as an original IGL ordinary share. Accordingly, personal tax considerations aside, the IGL capital restructure and the IGL unbundling should have no financial effect on an IGL member.

2.9 The implementation of the DLC Structure

Subject to the fulfillment of the suspensive conditions and upon the IGL unbundling, the DLC Agreements, which implement the DLC Structure, will come into effect. A brief explanation of the DLC Structure is given in paragraph 3 below and more details of the DLC Structure are included in paragraph 3 and Annexure I to this circular.

The pro forma financial information relating to IGL and Investec PLC subsequent to the IGL unbundling is included in Annexure VIII to this circular.

2.10 Listing of Investec PLC and the proposed Investec PLC capital raising

The secondary listing of Investec PLC ordinary shares in the Financials – “Speciality & Other Finance” sector of the JSE lists will be effective with effect from the commencement of business (09:00) on Monday, 22 July 2002, on which date it is expected that the conditional trading in the new Investec PLC ordinary shares to be issued pursuant to the Investec PLC capital listing will also commence at the commencement of business (08:00 London time) on the London Stock Exchange. The admission of Investec PLC’s ordinary shares to the UKLA’s Official List and admission to unconditional trading in Investec PLC ordinary shares on the London Stock Exchange is expected to be effective from the commencement of business (08:00 London time) on Monday, 29 July 2002.

In conjunction with the listing of Investec PLC ordinary shares on the London Stock Exchange and on the JSE, it is proposed, subject to prevailing market conditions, that Investec PLC raise capital by way of an issue of up to 10 million Investec PLC ordinary shares. At the request of the JSE the approval of IGL members will be sought for the proposed Investec PLC capital raising as though it were a specific issue of shares for cash.

The exact amount that is raised and the price at which the new Investec PLC ordinary shares will be issued will be established through an international book building exercise, having regard to market conditions which will result in the issue price of the new Investec PLC ordinary shares being determined by investor demand. Details of the final issue price of the new Investec PLC ordinary shares as well as the number of new Investec PLC ordinary shares will be announced as and when available.

2.11 The IGL name change

In order to align the names of the listed companies in the DLC Structure and in the interests of clarity, it is proposed to change IGL’s name from Investec Group Limited to Investec Limited. The special resolution to effect the name change is included in the notice convening the IGL general meeting attached to and forming part of this circular.

3. THE DLC STRUCTURE

Subject to the fulfillment of the suspensive conditions and upon the IGL unbundling, the DLC Agreements which implement the DLC Structure will come into effect. The concept of a DLC Structure is essentially simple, but the protections for shareholders are such that it is difficult to explain the concept simply and accurately and without deviating into complex detail. This section gives a basic description of the concept of a DLC Structure, the entities which will comprise the DLC Structure and how it effects an IGL member (and an existing Inhold member who becomes an IGL member pursuant to the Inhold unbundling). The description below is intentionally biased towards simplicity for ease of understanding. Further details of the DLC Structure and the DLC Agreements are set out in paragraph 3 and Annexure I to this circular.

The DLC Structure is, in essence, a mechanism to reconstitute Investec as a single corporate group after the unbundling of Investec PLC (refer to paragraph 2.7 above) – in effect binding the IGL group and the Investec PLC group back together in the same way as before, except that instead of a traditional group comprising one holding company and its subsidiary companies, there will be a synthetic group with two holding companies and their respective subsidiary companies.

Accordingly, despite the fact that IGL and Investec PLC are separate legal entities, the intention is that a shareholder should be largely indifferent as to the entity in which they hold shares. It is intended that the companies should, so far as is possible, function in all respects as if they were combined in a traditional group with consolidated accounts and (except for some shareholder protections designed to re-inforce the integrity of the structure) a shareholder body holding one class of shares.

It is vital for an appreciation of the concept, to understand that the DLC Structure does not assume that the individual companies' fortunes will always be the same, as this would clearly be unrealistic. There is thus no attempt to create or force equality between the companies. The intended equivalence is at the level of the rights attaching to a single share in either of the companies.

IGL and Investec PLC will have separate corporate identities with separate stock exchange listings. IGL will continue to have a primary listing on the JSE and Investec PLC is seeking a primary listing on the London Stock Exchange and a secondary listing on the JSE. Following Admission, Investec PLC will be eligible for inclusion in the FTSE indices. In South Africa, on the JSE, Investec PLC and IGL will be considered together, as a single enterprise, for the purposes of index inclusion.

In addition, neither Investec PLC nor IGL may issue any blanket cross-guarantees between themselves.

On implementation of the DLC Structure, an ordinary share held in either Investec PLC or IGL will give the holder the same effective economic interest in Investec, including the same rights to dividends, capital and voting, in respect of joint electorate matters. For every 100 IGL ordinary shares held, whether by an original IGL member or one who has received IGL ordinary shares as a result of the Inhold unbundling, as at the record date for the IGL capital restructure (which is the same as the record date for the IGL unbundling) such holder will, after the implementation of the IGL capital restructure and the IGL unbundling, hold 100 instruments, being 37 IGL ordinary shares and 63 Investec PLC ordinary shares.

4. NOTICES OF GENERAL MEETINGS

A general meeting of Inhold members will be held at 09:00 on Friday, 12 July 2002 for the purpose of considering and, if deemed fit, passing, with or without modification, the resolutions necessary for the Inhold unbundling, the Inhold delisting and the Inhold winding-up.

A general meeting of IGL members will be held at 09:30, or as soon thereafter as the Inhold general meeting is concluded, on Friday, 12 July 2002 for the purpose of considering and, if deemed fit, passing, with or without modification, the resolutions necessary for, *inter alia*, the IGL internal restructure, the IGL capital restructure, the IGL unbundling and the implementation of the DLC Structure.

5. OPINION AND RECOMMENDATION

The board of directors of Inhold and the board of directors of IGL as currently constituted, has considered the terms and conditions of the transactions and are of the opinion that they are fair and reasonable to Inhold members and IGL members, as the case may be, and recommend that Inhold members and IGL members vote in favour of the relevant resolutions necessary to implement the transactions. All the directors of Inhold and IGL who hold shares in Inhold and/or IGL intend to vote in favour of the resolutions for the implementation of the transactions.

6. ACTION TO BE TAKEN

If you are in any doubt as to the action you should take, please contact your stockbroker, attorney, accountant, banker or other professional adviser immediately.

6.1 Inhold members and IGL members who have disposed of their Inhold ordinary shares or IGL ordinary shares

Inhold members or IGL members who have disposed of all their ordinary shares in Inhold or IGL should hand this circular to the purchaser of such ordinary shares or the stockbroker, banker or other agent through whom the disposal was effected.

6.2 The Inhold general meeting and the IGL general meeting

6.2.1 The Inhold general meeting

A form of proxy (blue) for use by certificated Inhold members and dematerialised "own name" Inhold members who are unable to attend the Inhold general meeting, but who wish to be represented thereat, is attached to and forms part of this circular.

Dematerialised Inhold members must inform their CSDP or broker of their intention to attend the Inhold general meeting in order to be issued with the necessary authorisation to attend and vote at the Inhold general meeting. Alternatively dematerialised Inhold members who are unable to attend the Inhold general meeting, but who wish to be represented thereat, must provide their CSDP or broker with their voting instructions.

6.2.2 The IGL general meeting

A form of proxy (yellow) for use by certificated IGL members and dematerialised "own name" IGL members who are unable to attend the IGL general meeting, but who wish to be represented thereat, is attached to and forms part of this circular.

Dematerialised IGL members must inform their CSDP or broker of their intention to attend the IGL general meeting in order to be issued with the necessary authorisation to attend and vote at the IGL general meeting. Alternatively, dematerialised IGL members who are unable to attend the IGL general meeting, but who wish to be represented thereat, must provide their CSDP or broker with their voting instructions.

6.3 Surrender of documents of title

6.3.1 In order to give effect to the transactions, it will be necessary to recall all certificated Inhold ordinary shares and certificated IGL ordinary shares in issue.

6.3.2 Certificated Inhold members and certificated IGL members who wish to anticipate the Inhold unbundling and the IGL capital restructure, the IGL name change and the IGL unbundling and who do not wish to deal in their existing Inhold ordinary shares or their existing IGL ordinary shares, as the case may be, prior to the aforementioned transactions becoming effective, are requested to surrender their certificated Inhold ordinary shares or their certificated IGL ordinary shares to the transfer secretaries, namely, Computershare Investor Services Limited, 2nd Floor, Edura, 41 Fox Street, Johannesburg, 2001 (PO Box 61051, Marshalltown, 2107) in respect of Inhold ordinary shares or IGL ordinary shares listed on the JSE or the BSE, or, in the case of IGL ordinary shares listed on the NSX, to The Transfer Secretaries (Proprietary) Limited, Shop 12, Kaiserkrone Centre, Post Street Mall, Windhoek, Namibia (PO Box 2401, Windhoek, Namibia).

A second form of surrender will be sent to Inhold and IGL members together with the announcement of the results of the Inhold general meeting and the IGL general meeting.

6.3.3 The attention of Inhold members and IGL members is drawn to the fact that any Inhold member or IGL member who elects to receive new IGL share certificates and new Investec PLC share certificates will be required to dematerialise such shares certificates in order to trade their IGL ordinary shares or Investec PLC ordinary shares, as the case may be, on the JSE and in the case of IGL ordinary shares, also the BSE and NSX. The dematerialisation process can take between 24 hours and 10 days, depending on the volumes being processed by STRATE at the time of dematerialisation.

6.4 Taxation considerations

All Inhold members and IGL members are advised to seek appropriate professional advice regarding the effect of the transactions on their taxation position.



Investec

Group Limited

(Incorporated in the Republic of South Africa)
(Registration number 1925/002833/06)
Share code on the JSE: INT ISIN: ZAE000012555
Share code on the NSX: IVC
Share code on the BSE: INV.BT
("IGL" or "the company")



Investec

Holdings Limited

(Incorporated in the Republic of South Africa)
(Registration number 1985/005574/06)
Share code on the JSE: INH ISIN: ZAE000003562
("Inhold")

Executive directors

Stephen Koseff (*Chief Executive Officer*)
Bernard Kantor (*Managing Director*)
David M Lawrence
Bradley Tapnack

Non-executive directors

Hugh S Herman (*Chairman*)
Sam E Abrahams
Dr Hilton K Davies
Graham H Davin
Donn E Jowell
Ian R Kantor
Daphne R Motsepe
Dr Morley Z Nkosi
Peter R S Thomas

Directors

Ian R Kantor (*Chairman*)
Bas Kardol (*Deputy Chairman*)*
Glynn R Burger
Graham H Davin
Hugh S Herman
Bernard Kantor
Stephen Koseff
Peter R S Thomas

*Dutch

CIRCULAR TO INHOLD MEMBERS AND IGL MEMBERS

I. INTRODUCTION

It was announced on 22 November 2001 that IGL would pursue a listing on the London Stock Exchange and the JSE using a DLC Structure.

Further it has been decided that, as part of the implementation of the DLC Structure, Inhold will, subsequent to the Inhold reorganisation, distribute *in specie* its entire holding of IGL ordinary shares to Inhold members, pursuant to which Inhold will be delisted from the JSE and wound-up in terms of a members' voluntary winding-up.

IGL members and Inhold members (who will become IGL members pursuant to the Inhold unbundling) are advised that, subject to the fulfillment of the suspensive conditions, IGL will:

- accelerate the conversion of the IGL convertible preference shares;
- cancel certain sale agreements with Fintique II and Fintique III and enter into a new sale agreement with Fintique II to deliver IGL ordinary shares in exchange for Investec Bank ordinary shares;
- restructure its subsidiaries so that Investec PLC holds the PLC operations;
- adopt a new memorandum and articles of association;
- restructure its ordinary share capital to effectively reduce the number and par value of the IGL ordinary shares in issue;
- distribute 65 382 130 Investec PLC ordinary shares held by IGL subsequent to the IGL internal restructure;
- enter into the DLC Agreements;
- change the name of IGL from Investec Group Limited to Investec Limited; and
- list Investec PLC on the London Stock Exchange, with a secondary listing on the JSE. IGL will retain its primary listing on the JSE and its secondary listings on the BSE and NSX.

It is important to note that a holder of 100 IGL ordinary shares will, after the implementation of the IGL capital restructure and the IGL unbundling hold 100 instruments – those instruments will comprise 37 IGL ordinary shares and 63 Investec PLC ordinary shares and, market conditions aside, should individually and collectively have the same value as the original 100 IGL ordinary shares held by such holder.

The purpose of this circular is to provide Inhold members and IGL members with information regarding the transactions referred to above and to convene separate general meetings of Inhold members and IGL members at which the special and ordinary resolutions necessary to give effect to the transactions will be proposed.

2. RATIONALE

Investec is an international, specialist banking group that provides a diverse range of financial products and services to a niche client base located principally in South Africa and the United Kingdom, but also in certain other countries including Australia, the United States and Israel. Investec is organised as a network comprising four business divisions:

- **Investment Banking**, with corporate finance, institutional research, sales and trading, direct investments and private equity operations;
- **Treasury and Specialised Finance**, with a range of banking and financial market activities;
- **Private Client Activities**, with private banking and private client stockbroking and portfolio management operations; and
- **Asset Management**, with asset management and assurance activities.

In addition, Investec's South African head office provides certain integrating Group-wide functions such as risk management, information technology, finance, investor relations, marketing, human resources and organisational development. It also has responsibility for the Group's central funding as well as certain other activities such as property, trade finance and traded endowment operations.

Investec's strategy is to be one of the world's leading specialist banking groups, differentiated and driven by a passionate commitment to its distinctive culture and its people. Investec pursues its strategy, through an emphasis on reinforcing a specialised and focused approach, pursuing growth opportunities, leveraging group skills and perpetuating its culture.

In 1992, Investec made its first international acquisition when it acquired Allied Trust Bank in London, which was later re-named Investec Bank (UK) Limited. Since 1992, Investec has made in excess of 25 acquisitions in over 10 countries. As at 31 March 2002, international operations accounted for 53% of headline attributable earnings and 64% of its assets.

Investec competes in an increasingly global market where the availability and cost of capital is vitally important. By undertaking the transactions, Investec will benefit by increasing its global profile, enhancing its capital raising capability, lowering its cost of capital and improving access to international capital markets. This will, in turn, enhance Investec's ability to grow and develop its Southern African and other businesses.

3. OUTLINE OF THE DLC STRUCTURE

Subject to the fulfillment of the suspensive conditions and upon the IGL unbundling, the DLC Agreements which implement the DLC Structure will come into effect. The concept of a DLC Structure is essentially simple, but the protections for shareholders are such that it is difficult to explain the concept simply and accurately and without deviating into fairly complex detail. The description below is intentionally biased towards simplicity for ease of understanding. Further details of the DLC Structure and the DLC Agreements are set out in Annexure I to this circular.

3.1 DLC concept

The DLC Structure is, in essence, a mechanism to reconstitute Investec as a single corporate group after the unbundling of Investec PLC – in effect binding the IGL group and the Investec PLC group back together in the same way as before, except that instead of a traditional group comprising one holding company and its subsidiary companies, there will be a synthetic group with two holding companies and their respective subsidiary companies.

Accordingly, despite the fact that IGL and Investec PLC are separate legal entities, the intention is that a shareholder should be largely indifferent as to the entity in which they hold shares. It is intended that the companies should, as far as is possible, function in all respects as if they were combined in a traditional group with consolidated accounts and (except for some shareholder protections designed to re-inforce the integrity of the structure) a shareholder body holding one class of shares.

It is vital for an appreciation of the concept to understand that the DLC Structure does not assume that the individual company's fortunes will always be the same, as this would clearly be unrealistic. There is thus no attempt to create or force equality between the companies. The intended equivalence is at the level of the rights attaching to a single share in either of the companies.

3.2 Separate entities and listings

IGL and Investec PLC will have separate corporate identities with separate stock exchange listings. IGL will continue to have a primary listing on the JSE and Investec PLC is seeking a primary listing on the London Stock Exchange and a secondary listing on the JSE. Following Admission, Investec PLC will be eligible for inclusion in the FTSE indices. In South Africa, on the JSE, Investec PLC and IGL will be considered together, as a single enterprise, for the purposes of index inclusion.

Neither Investec PLC nor IGL may issue any blanket cross-guarantees between themselves.

3.3 Holdings of IGL ordinary shares and Investec PLC ordinary shares

On implementation of the DLC Structure, an ordinary share held in either Investec PLC or IGL will give the holder the same effective economic interest in Investec, including the same rights to dividends, capital and voting in respect of joint electorate matters. For every 100 IGL ordinary shares held, whether as an original IGL member or one who has received IGL ordinary shares as a result of the Inhold unbundling, as at the record date for the IGL capital restructure (which is the same as the record date for the IGL unbundling) such holder will, after the implementation of the IGL capital restructure and the IGL unbundling, hold 100 instruments, being 37 IGL ordinary shares and 63 Investec PLC ordinary shares.

3.4 Unified board and management

IGL and Investec PLC will operate and be managed as if they were a single economic enterprise.

However, as IGL and Investec PLC will be separate corporate entities, each will continue to have its own board of directors, but the Boards will comprise the same persons. Each board will, in addition to its duties to its company, be both authorised and empowered (by the articles of association of both companies) to have regard to the interests of the ordinary shareholders of both IGL and Investec PLC in the management of Investec.

3.5 Common economic and voting interests

IGL members and Investec PLC shareholders will have economic and voting interests in Investec very much as if it were a single corporate group. The economic and voting interests represented by a single ordinary share in one company relative to the economic and voting interests of a single ordinary share in the other company will initially be the same. This relationship, known as the "Equalisation Ratio", will initially be 1:1. For reasons of practical expediency it is anticipated that the Equalisation Ratio will remain 1:1, but the DLC Agreements do make provision for an adjustment to the Equalisation Ratio in appropriate circumstances – see "Maintenance of economic and voting interests" below and in Annexure I to this circular.

3.6 Maintenance of economic and voting interests

If either IGL or Investec PLC undertakes an Action (an "Initial Action") which, having regard to the then prevailing Equalisation Ratio, provides a disproportionate economic benefit to one company's ordinary shareholders then:

- a Matching Action must be taken so as to ensure that the ordinary shareholders in the other company ("the "disadvantaged shareholders") receive an equivalent (but not necessarily identical) economic benefit; or
- the disadvantaged shareholders can agree that no Matching Action is required; or
- the ratio in which the disadvantaged shareholders share in the profits, capital and voting rights of the Group will be increased relative to the rights of a shareholder in the other company (by adjusting the Equalisation Ratio) by an amount which is appropriate to redress the disproportionate effect introduced by the Initial Action.

With regard to cash dividends, if either IGL or Investec PLC pays a dividend to its ordinary shareholders, the other company will be required to pay an equivalent dividend unless the Boards decide to take some other form of Matching Action or adjust the Equalisation Ratio. To enable matching dividends to be paid, IGL and Investec PLC have each issued Dividend Access Shares for the benefit of ordinary shareholders in the other company. Accordingly, subject to any regulatory approvals, an ordinary shareholder may receive his dividend entitlement from either or both companies.

3.7 Voting arrangements

In terms of the DLC Agreements, the IGL Articles and the Investec PLC Articles, special voting arrangements are to be implemented so that:

- the ordinary shareholders of both companies vote together as if they were a single decision-making body on matters affecting the ordinary shareholders of each company in similar ways ("Joint Electorate Actions"). Unless there is a change in the Equalisation Ratio, each IGL ordinary share will effectively have the same voting rights as each Investec PLC ordinary share on Joint Electorate Actions; and
- if the relevant matter is such that the two bodies of ordinary shareholders might have divergent interests, or is proposing a change to the DLC Structure (a "Class Rights Action"), the prior approval of the ordinary shareholders of both companies voting separately is required. In practice this gives the shareholders of both companies an effective veto right.

Under the terms of the DLC Agreements and in order to facilitate voting as if IGL and Investec PLC were a single enterprise, IGL will issue Special Converting Shares and Investec PLC will issue a Special Voting Share.

3.8 Restrictions on takeovers of one company only

The IGL Articles and Investec PLC Articles provide that a person (and his connected parties) cannot gain control of one company without having made an equivalent offer to the ordinary shareholders of both companies on equivalent terms. The articles of association of both companies provide that a compulsory offer must be made if any person (with concert parties, if such is the case) gains control of 30% or more of the voting rights of ordinary shareholders of either IGL or Investec PLC or 30% or more of the total votes exercisable by the joint electorate.

It is noted that the foregoing will be enforced by the IGL Board and the Investec PLC Board through the IGL Articles and Investec PLC Articles. The Securities Regulation Code on Takeovers and Mergers and the Rules of the SRP will only apply when the threshold (presently 35%) provided for in the SRP Code is reached in which event it will only apply to IGL.

3.9 Termination

On termination of the DLC Structure (for whatever reason), it will be necessary to ensure the structure is unwound so that, immediately following termination, the economic interest of a holder of one IGL ordinary share will be the same as the economic interest of a holder of one Investec PLC ordinary share (or that those interests are in proportion to the Equalisation Ratio if that is not then 1:1). This will be achieved through the issue of an additional class of shares (known as "Special Converting Shares") by IGL and Investec PLC, to be held on trust pending termination, which convert into (and will be converted into) ordinary shares in the issuing company and which will be transferred out of the trust to the ordinary shareholders of the other company following termination. Simply put, IGL members will receive Investec PLC ordinary shares and Investec PLC members will receive IGL ordinary shares so that, after receipt, each shareholder will have the same percentage holding in each company as that previously held in the Group.

3.10 Financial reporting subsequent to the implementation of the DLC Structure

Subsequent to the implementation of the DLC Structure, it is intended that IGL and Investec PLC will publish a single primary set of consolidated financial statements, denominated in pounds sterling and prepared in accordance with UK GAAP and IGL will publish consolidated financial statements denominated in Rand and prepared in accordance with SA GAAP. IGL and Investec PLC will furthermore also prepare and publish any other financial information needed to meet their respective local requirements. The financial year-end of both IGL and Investec PLC will be 31 March.

3.11 Cash dividends

IGL will continue to declare and pay dividends and other distributions in Rand. Investec PLC will declare and pay dividends and other distributions in pounds sterling.

3.12 Regulation

The IGL group and Investec PLC group are subject to extensive regulation by governmental and self-regulatory organisations in various jurisdictions in which they operate around the world, including, in particular, SARB in South Africa and the FSA in the United Kingdom. The requirements imposed by Investec's regulations, including capital adequacy, are designed to ensure the integrity of the financial markets and to protect customers and other third parties who deal with Investec. The South African Ministry of Finance and the FSA have imposed certain conditions specifically in respect of the DLC Structure, relating, *inter alia*, to prudential regulation, national identity, listing and shareholder arrangements, and exchange control matters. Full details have been included in paragraph 2.9 of Annexure I to this circular.

4. PROCEDURE FOR THE IMPLEMENTATION OF THE DLC STRUCTURE

4.1 The Inhold reorganisation, the Inhold unbundling, the Inhold delisting and the Inhold winding-up

4.1.1 Details of the Inhold reorganisation

(i) *The conversion of the IGL convertible preference shares held by Inhold*

Inhold holds 2 000 000 IGL convertible preference shares, bearing a dividend payment calculated at a variable rate of 45% of the prime overdraft rate as quoted by Investec Bank. The IGL convertible preference shares are convertible into IGL ordinary shares on a 1 for 1 basis when the dividend on an IGL ordinary share exceeds the dividend on the IGL convertible preference share.

Inhold agreed to the early conversion of the IGL convertible preference shares with effect from 18 June 2002, in consideration for the receipt of R35 million from IGL to compensate for the present value of the lower dividend that Inhold is expected to receive by holding IGL ordinary shares earlier than envisaged by the conversion terms.

The terms of the IGL convertible preference shares will be amended to allow for their early conversion by the adoption of the IGL Articles referred to in paragraph 4.4 below.

(ii) *Cancellation of certain agreements between Inhold and Fintique II and Fintique III*

Fintique II and Fintique III are employee ownership plans which were structured and arranged by Investec and substantially funded from external sources. Further details regarding Fintique II and Fintique III are included in Annexure XV to this circular.

Inhold was a party to an agreement in terms of which it acquired and agreed that on 31 July 2008 it would take delivery of 3 573 994 Investec Bank shares from Fintique II against delivery of 4 033 507 Inhold ordinary shares, and simultaneously deliver the 3 573 994 Investec Bank shares to IGL against delivery of 3 573 994 IGL ordinary shares. Inhold agreed to the cancellation of this agreement in return for which it received compensation of 75 000 IGL ordinary shares from Fintique II.

On 31 March 1999, Inhold entered into an agreement with Fintique III, in terms of which Inhold has purchased and agreed that on 15 December 2004 it would take delivery of 6 800 000 IGL ordinary shares in exchange for the delivery of 7 480 000 Inhold ordinary shares. Inhold agreed to the cancellation of this agreement in return for which it received compensation of 120 000 IGL ordinary shares from Fintique III.

(iii) *Sale by Inhold of IGL ordinary shares, settlement of outstanding liabilities and redemption of cumulative redeemable preference shares in Inhold*

Inhold sold 2 985 176 IGL ordinary shares between 10 June 2002 and 12 June 2002 for a total amount of R505 million. This, together with the settlement of R35 million it received as set out in (i) above, has enabled Inhold to redeem its 800 issued cumulative redeemable preference shares of 50 cents each at par for R382 million and settle other liabilities of R158 million.

(iv) **Transfer of unclaimed dividends**

At 31 March 2002, Inhold members had claims of R25 598 for unclaimed dividends, which moneys, together with the unclaimed dividends arising from the dividend declared by Inhold for the period ended 31 March 2002, will be transferred into a trust for the benefit of the relevant members.

Following the Inhold reorganisation as set out above, Inhold will have no liabilities and its only asset will be its shareholding of 31 850 682 ordinary shares in IGL, which will be unbundled to Inhold members as set out in 4.1.2 below.

The pro forma financial effects of the Inhold reorganisation are included in the pro forma financial information relating to Inhold in Annexure IV to this circular.

4.1.2 Details of the Inhold unbundling

4.1.2.1 Ratio of entitlement

Subject to the approval of the Inhold unbundling by Inhold members, Inhold will distribute its entire shareholding in IGL to Inhold members registered as such on the record date for the Inhold unbundling, in the ratio of 86.04 IGL ordinary shares for every 100 Inhold ordinary shares held on the record date for the Inhold unbundling, by way of a dividend *in specie* and a reduction of share capital and share premium.

A table of entitlement to IGL ordinary shares to which an Inhold member is entitled in terms of the Inhold unbundling, where the number of Inhold ordinary shares held on the record date for the Inhold unbundling is not a multiple of 100, is set out in Annexure XI to this circular. It should be noted that an Inhold member's entitlement to IGL ordinary shares in terms of the abovementioned ratio will be rounded down to the nearest whole number if any fraction resulting is less than 0.5 or rounded up to the nearest whole number if any fraction resulting is equal to or greater than 0.5.

4.1.2.2 Pro forma financial effects of the Inhold unbundling

The pro forma financial effects of the Inhold unbundling are included in the pro forma financial information relating to Inhold in Annexure IV to this circular.

4.1.2.3 Participation in the IGL capital restructure and the IGL unbundling

Inhold members who **do not** trade their entitlement to IGL ordinary shares received in terms of the Inhold unbundling on Friday, 19 July 2002 (being the last day to trade in IGL ordinary shares in order to participate in the IGL capital restructure and the IGL unbundling), will automatically participate in the IGL capital restructure and the IGL unbundling referred to in paragraphs 4.6 and 4.7 below. Inhold members are advised that in order to trade their entitlement to IGL ordinary shares on Friday, 19 July 2002, their Inhold ordinary shares must be dematerialised by Thursday, 11 July 2002.

An Inhold member who participates in the IGL capital restructure and the IGL unbundling will, for each 100 IGL ordinary shares to which he is entitled in terms of the Inhold unbundling, **instead** receive 37 IGL ordinary shares and 63 Investec PLC ordinary shares.

A table of entitlement to IGL ordinary shares and Investec PLC ordinary shares to which an Inhold member who participates in the IGL capital restructure and the IGL unbundling is entitled where the number of IGL ordinary shares received in terms of the Inhold unbundling is not a multiple of 100 is set out in Annexure XI to this circular.

4.1.3 Details of the Inhold delisting and the Inhold winding-up

4.1.3.1 The Inhold delisting

Subsequent to the Inhold reorganisation and the Inhold unbundling, Inhold will have no assets or liabilities and, accordingly, an application will be made to the JSE for the delisting of Inhold from the JSE, and Inhold will be wound up by way of a members' voluntary winding-up. The listing of Inhold on the JSE will be suspended from the commencement of business (09:00) on Friday, 19 July 2002 and will be terminated from the commencement of business (09:00) on Friday, 26 July 2002.

4.1.3.2 *The Inhold winding-up*

Inhold will be wound-up by way of a members' voluntary winding-up in terms of sections 349 and 350 of the Act.

In terms of the Inhold winding-up, Inhold will pay, as a final liquidation dividend, the balance, if any, of the cash held by it after any other liabilities relating to the Inhold reorganisation, the Inhold unbundling and the Inhold winding-up have been settled, to Inhold members registered as such on the record date for the Inhold unbundling. The amount of such final liquidation dividend will be published on finalisation of the Inhold winding-up and it is currently anticipated that such amount will be approximately one cent per Inhold ordinary share. Subject to the approval of Inhold members, it is proposed that, should the final liquidation dividend be less than such amount which, in the opinion of the liquidator appointed for the Inhold winding-up, it would not be warranted to distribute to Inhold members by virtue of the fact that the costs involved in distributing such amount to Inhold members will exceed any amount distributed, to pay such amount to a charitable organisation.

4.1.4 **Procedure for the implementation of the Inhold unbundling, the Inhold delisting and the Inhold winding-up**

- 4.1.4.1 A general meeting of Inhold members will be held at 09:00 on Friday, 12 July 2002 to consider and, if deemed fit, pass the ordinary and special resolutions required to implement the Inhold unbundling, the Inhold delisting and the Inhold winding-up.
- 4.1.4.2 The last day to trade in existing Inhold ordinary shares in order to participate in the Inhold unbundling will be Thursday, 18 July 2002.
- 4.1.4.3 Inhold members who do not wish to automatically participate in the IGL capital restructure and the IGL unbundling in respect of their entitlement to the IGL ordinary shares received in terms of the Inhold unbundling, will be able to trade their entitlement to IGL ordinary shares on Friday, 19 July 2002 (being the last day to trade IGL ordinary shares in order to participate in the IGL capital restructure and the IGL unbundling). However, certificated Inhold members will first need to dematerialise their Inhold ordinary shares prior to the close of business on Thursday, 11 July 2002 in order to be able to trade their entitlement to IGL ordinary shares on Friday, 19 July 2002.
- 4.1.4.4 Certificated Inhold members will be required to surrender their documents of title in respect of their Inhold ordinary shares in accordance with the procedure in paragraph 9 below in order to be able to receive their entitlement to IGL ordinary shares and Investec PLC ordinary shares in terms of the Inhold unbundling, the IGL capital restructure and the IGL unbundling.
- 4.1.4.5 Certificated Inhold members who do not dematerialise their Inhold ordinary shares prior to the close of business on Thursday, 11 July 2002, will, on surrender of their Inhold documents of title, and subject to the election made by such members in accordance with the surrender procedure in paragraph 9 below, be issued new IGL share certificates and new Investec PLC share certificates, which share certificates will be posted, at the risk of the Inhold member concerned, to the address reflected in the register of Inhold members on the record date for the Inhold unbundling.
- 4.1.4.6 **Certificated Inhold members are advised that, should they elect to receive the IGL ordinary shares and the Investec PLC ordinary shares due to them in certificated form, they will need to dematerialise such shares prior to trading in them. Certificated Inhold members are referred to paragraph 9.3 of this circular for details of an issuer-sponsored nominee programme to assist Inhold members who are eligible to do so to dematerialise their existing certificated shares and an offer to Inhold members who are eligible to do so to participate in the said programme.**
- 4.1.4.7 Dematerialised Inhold members and existing certificated Inhold members who dematerialise their Inhold ordinary shares prior to Thursday, 11 July 2002, will have the IGL ordinary shares to be received by them in terms of the Inhold unbundling credited to their safe custody accounts on Friday, 26 July 2002.
- 4.1.4.8 Inhold members resident outside South Africa must satisfy themselves as to the full observance of the laws of the country or territory of residence, as well as the application to them of the Exchange Control Regulations of South Africa, summarised in paragraph 8 below.
- 4.1.4.9 Inhold members' attention is drawn to the taxation considerations summarised in paragraph 7 below.

4.2 The IGL reorganisation

(i) *The conversion of the IGL convertible preference shares*

IGL has agreed to accelerate the conversion of 2 000 000 IGL convertible preference shares held by Inhold by way of an issue of 2 000 000 IGL ordinary shares to Inhold, together with a payment of R35 million, with effect from 18 June 2002, which payment will compensate for the present value of the lower dividend that Inhold is expected to receive by holding IGL ordinary shares earlier than envisaged by the conversion terms; The terms of the IGL convertible preference shares will be amended to allow for their early conversion by the adoption of the IGL Articles referred to in paragraph 4.4 below.

(ii) *Cancellation of agreement with Inhold*

IGL has agreed to the cancellation of an agreement with Inhold in terms of which IGL acquired and agreed that on 31 July 2008 it will take delivery of 3 573 994 Investec Bank shares from Inhold in exchange for the issue of 3 573 994 IGL ordinary shares. Inhold had acquired the shares in question from Fintique II and has agreed to cancel that agreement. IGL will, on 31 July 2008, take delivery of the 3 573 994 Investec Bank shares against delivery of 3 573 994 IGL ordinary shares; and

(iii) *Acquisition of compulsorily convertible debentures issued by Investec Bank from Fintique III*

IGL entered into an agreement with Fintique III to accelerate the implementation of certain existing agreements which would have taken place in December 2004. Accordingly, with effect from 18 June 2002, IGL acquired the right to receive the redemption proceeds and the obligation to subscribe for Investec Bank ordinary shares in respect of 9 500 000 compulsorily convertible debentures issued by Investec Bank for a total consideration of R1 656 million which was settled by the issue of 9 500 000 IGL ordinary shares. Fintique III has agreed to waive its right to receive ordinary dividends until:

- 15 December 2004 (the original date for implementation) in respect of 7 500 000 of these IGL ordinary shares and has undertaken not to dispose of these IGL ordinary shares before that date; and
- 31 March 2008 in respect of 2 000 000 of these IGL ordinary shares and has undertaken not to dispose of these IGL ordinary shares before that date. The IGL share scheme has agreed that on 15 December 2004 it will acquire these 2 000 000 IGL ordinary shares and has undertaken to waive its right to receive ordinary dividends until 31 March 2008 and not to dispose of these shares until that date, in exchange for the delivery to Fintique III of 2 000 000 IGL ordinary shares which are not subject to any restrictions.

The pro forma financial effects of the IGL reorganisation are included in the pro forma financial information relating to IGL and Investec PLC in Annexure VIII of this circular.

4.3 The IGL internal restructure

In order to implement the DLC Structure, IGL will transfer the PLC operations to Investec PLC or subsidiaries of Investec PLC. The effect will be that all the PLC operations will be held by Investec PLC or its subsidiaries with the balance of the existing operations being held by IGL or its subsidiaries. Investec PLC is currently a wholly-owned subsidiary of IGL. As the subsidiaries to be transferred and the intermediary holding companies are wholly-owned subsidiaries of IGL, IGL's beneficial interest in them is not changed.

Approval by IGL members of the IGL internal restructure is a technical requirement in terms of the Act as the IGL internal restructure will be a disposal by IGL of a greater part of its assets, albeit to wholly-owned subsidiaries of IGL. The required approval is included as an ordinary resolution in the notice convening the IGL general meeting, which is attached to and forms part of this circular.

As stated above, the subsidiaries being transferred in terms of the IGL internal restructure and the intermediary holding companies are wholly-owned subsidiaries of IGL. Accordingly, the IGL internal restructure will have no effect on the earnings, headline earnings, net asset value or tangible net asset value per IGL ordinary share for the year ended 31 March 2002 or at 31 March 2002, as the case may be.

Subsequent to the IGL internal restructure, IGL will hold 70 633 746 Investec PLC ordinary shares. Prior to the IGL unbundling, 5 251 616 of the Investec PLC ordinary shares will be transferred to the IGL share scheme to ensure that all the IGL employee ownership plans will be able to give effect to Group policy that employees should acquire both IGL and Investec PLC shares in order to maintain the unity of the Group. IGL will then unbundle 65 382 130 Investec PLC ordinary shares in terms of the IGL unbundling.

4.4 Adoption of a new memorandum and articles of association by IGL

Certain of the provisions of the DLC Agreements will be reflected in the IGL Memorandum and Articles. For convenience of administration the IGL Memorandum and Articles will be aligned, insofar as the laws of their respective jurisdictions permit, with those of Investec PLC. The IGL Board proposes to adopt a new memorandum and articles of association which accomplish the aforementioned and also incorporate the various amendments to the Act and the Listings Requirements which have come into force over the past few years.

The salient extracts from the proposed new IGL Articles are reflected in Annexure XIV to this circular. The special resolution to be passed by IGL members which provides for the adoption of the IGL Memorandum and Articles is included in the notice convening the IGL general meeting, which is attached to and forms part of this circular.

4.5 The IGL name change

In order to align the names of the listed companies in the DLC Structure and in the interests of clarity, it is proposed to change IGL's name from Investec Group Limited to Investec Limited. The special resolution to effect the name change is included in the notice convening the IGL general meeting attached to and forming part of this circular.

The JSE has approved the change of name of the company from Investec Group Limited to Investec Limited with effect from the commencement of business on Monday, 22 July 2002.

The procedure for the surrender of existing IGL ordinary share certificates in terms of the IGL name change and the IGL capital restructure is set out in paragraph 9 below.

4.6 The IGL capital restructure

4.6.1 Details of the IGL capital restructure

In order to implement the DLC Structure, IGL will restructure its share capital in terms of which:

- the par value of the ordinary shares in the issued and authorised share capital of IGL will be reduced from R0,60 each to R0,001 each; and
- each 100 ordinary shares in the authorised and issued share capital of IGL will be reduced to 37 ordinary shares.

The IGL capital restructure will be effected by way of a share split of existing IGL ordinary shares, which will be followed by a capital reduction by way of a transfer to IGL's reserves.

The net effect of the IGL share split and the IGL capital reduction will be to reduce the number and par value of IGL ordinary shares held by each IGL member so that an IGL member who holds 100 IGL ordinary shares with a nominal value of 60 cents each before the IGL capital restructure, will hold 37 IGL ordinary shares with a nominal value of 0.1 cent each after the IGL capital restructure.

A table of entitlement to IGL ordinary shares to which an IGL member is entitled after the IGL capital restructure where the number of IGL ordinary shares held on the record date for the IGL capital restructure is not a multiple of 100 is set out in Annexure XIII to this circular. It should be noted that an IGL member's entitlement to IGL ordinary shares in terms of the abovementioned ratio will be rounded down to the nearest whole number if any fraction resulting is less than 0.5 or rounded up to the nearest whole number if any fraction resulting is equal to or greater than 0.5.

An application has been made to the JSE to amend the listing of IGL's share capital on the JSE to take account of the IGL capital restructure.

The record date for the IGL capital restructure will be the close of business (17:00) on Friday, 26 July 2002 – the same date as the record date for the IGL unbundling.

The pro forma financial effect of the IGL capital restructure and the IGL unbundling on an IGL member is set out in paragraph 4.7.1.2 below

4.6.2 Procedure for the surrender of existing share certificates

Certificated IGL members will be required to surrender their documents of title in respect of their IGL ordinary shares in accordance with paragraph 9 below in order to, subject to the election made by such members in terms of paragraph 9 below, be able to receive new IGL share certificates that reflect the IGL capital restructure. The safe custody accounts that dematerialised IGL members hold with their CSDP or broker will be automatically amended to reflect the IGL capital restructure.

4.7 The IGL unbundling

4.7.1 Details of the IGL unbundling

4.7.1.1 Ratio of entitlement

Subject to the fulfillment of the suspensive conditions and subsequent to the IGL capital restructure, IGL will distribute its entire shareholding of Investec PLC ordinary shares to IGL members registered as such on the record date for the IGL unbundling, in the ratio of 63 Investec PLC ordinary shares for every 100 IGL ordinary shares held prior to the IGL capital restructure by way of a dividend *in specie* and a reduction of share capital and share premium.

A table of entitlement to Investec PLC ordinary shares to which an IGL member is entitled where the number of IGL ordinary shares held on the record date for the IGL unbundling is not a multiple of 100, is set out in Annexure XIII to this circular. It should be noted that an IGL member's entitlement to IGL ordinary shares in terms of the abovementioned ratio will be rounded down to the nearest whole number if any fraction resulting is less than 0.5 or rounded up to the nearest whole number if any fraction resulting is equal to or greater than 0.5.

4.7.1.2 Pro forma financial effects of the IGL capital restructure and IGL unbundling

The combined effect of the IGL capital restructure and the IGL unbundling will be that the number of IGL ordinary shares held by an IGL member before the IGL capital restructure and the IGL unbundling will equal the aggregate number of IGL ordinary shares and Investec PLC ordinary shares held by that IGL member after the IGL capital restructure and the IGL unbundling, i.e. for every 100 IGL ordinary shares held before the IGL capital restructure and the IGL unbundling, an IGL member will, after the IGL capital restructure and IGL unbundling, hold 37 IGL ordinary shares and 63 Investec PLC ordinary shares, being 100 shares in the aggregate.

The IGL ordinary shares and the Investec PLC ordinary shares have identical economic rights and, market conditions aside, each of those shares should have the same market value as an original IGL ordinary share. Accordingly, personal tax considerations aside, the IGL capital restructure and the IGL unbundling should have no financial effect on an IGL member:

Subsequent to the implementation of the DLC Structure, the holder of an IGL ordinary share and/or an Investec PLC ordinary share, will be entitled to participate in the earnings, net asset value and tangible net asset value of Investec on the same effective economic basis as which an existing IGL member currently participates in the IGL group.

Accordingly, because of the implementation of a DLC Structure, the IGL capital restructure and the IGL unbundling should, collectively, have no financial effect on the earnings, headline earnings, net asset value or tangible net asset value per IGL ordinary share.

Pro forma financial information relating to IGL and Investec PLC subsequent to the IGL unbundling is included in Annexure VIII to this circular.

4.7.2 Procedure for the implementation of the IGL unbundling

- 4.7.2.1 A general meeting of IGL members will be held at 09:30, or as soon thereafter as the Inhold general meeting is concluded, on Friday, 12 July 2002 to consider and, if deemed fit, pass the necessary resolution to implement the IGL unbundling.
- 4.7.2.2 The last day to trade in IGL ordinary shares in order to participate in the IGL unbundling will be Friday, 19 July 2002.
- 4.7.2.3 Certificated IGL members will be required to surrender their documents of title in respect of their IGL ordinary shares in accordance with the procedure in paragraph 9 below in order to be able to receive their entitlement to Investec PLC ordinary shares in terms of the IGL unbundling.
- 4.7.2.4 Certificated IGL members who do not dematerialise their IGL ordinary shares prior to the close of business on Friday, 12 July 2002 will, on surrender of their IGL documents of title, and subject to the election made by such members in accordance with the surrender procedure in paragraph 9 below, be issued with new IGL ordinary shares and new Investec PLC ordinary shares in certificated form.
- 4.7.2.5 **Certificated IGL members are advised that they will have to dematerialise the IGL ordinary shares received by them in terms of the IGL capital restructure and the IGL name change and the Investec PLC ordinary shares received by them in terms of the IGL unbundling, prior to trading in such IGL ordinary shares and Investec PLC ordinary shares. Certificated IGL members are referred to paragraph 9.3 of this circular for details of an issuer-sponsored nominee programme to assist IGL members who are eligible to do so to dematerialise their existing certificated IGL ordinary shares and an offer to IGL members who are eligible to do so to participate in the said programme.**
- 4.7.2.6 Dematerialised IGL members and existing certificated IGL members who dematerialise their IGL ordinary shares prior to the close of business on Friday, 12 July 2002, will automatically have the Investec PLC ordinary shares credited to their safe custody accounts on Monday, 29 July 2002.

- 4.7.2.7** For those shareholders of Investec PLC who will be registered on the principal register of Investec PLC in the UK, Investec PLC ordinary share certificates or share statements, as the case may be, will, where applicable, be posted by registered post, at the risk of the member, to the address set out in the register, on or about, Monday, 29 July 2002 if the documents of title are received prior to the close of business on Thursday, 25 July 2002 in respect of Inhold ordinary shares or, in respect of IGL ordinary shares, on Friday, 26 July 2002, or within five business days of receipt by the transfer secretaries of the applicable form of surrender and relevant documents of title.
- 4.7.2.8** In relation to those certificated shareholders of Investec PLC who will be registered on the branch register, the South African transfer secretaries will, where applicable and subject to paragraph 9 and the election made in terms of that paragraph, send the Investec PLC ordinary share certificates in respect of the Investec PLC ordinary shares by pre-paid registered post from South Africa to the addresses registered in the branch register in accordance with the provisions of paragraph 8.5, or in accordance with any valid and lawful instructions to the contrary then in force, on Monday, 29 July 2002 if the documents of title are received prior to the close of business on Thursday, 25 July 2002 in respect of Inhold ordinary shares, or, in respect of IGL ordinary shares on Friday, 26 July 2002, or within five business days of receipt by the transfer secretaries of the applicable form of surrender and relevant documents of title.
- 4.7.2.9** IGL members resident outside of South Africa must satisfy themselves as to full observance of the laws of their country or territory of residence, as well as the application of the Exchange Control Regulations of South Africa summarised in paragraph 8 below.
- 4.7.2.10** IGL members' attention is drawn to the taxation considerations summarised in paragraph 7 below.

4.8 The implementation of the DLC Structure

Subject to the fulfillment of the suspensive conditions and upon the IGL unbundling, the DLC Agreements which implement the DLC Structure will come into effect. A brief explanation of the DLC Structure is given in paragraph 3 above and more details of the DLC Structure are included in Annexure I to this circular.

The implementation by IGL of the DLC Structure will, *inter alia*, include the creation of three additional classes of share capital, comprising:

- the Dividend Access Shares described in paragraph 7.4 of Annexure I to this circular comprising, the SA DAS Share and the SA DAN Share, each being a redeemable preference share with a par value of R1,00; and
- the IGL Special Converting Shares described in paragraph 2.5 of Annexure I to this circular, comprising convertible redeemable preference shares with a par value of R0,001 each, the issued number of which will mirror the issued number of Investec PLC ordinary shares whilst the Equalisation Ratio is 1:1.

The resolutions required to be passed by IGL members and which provide for, *inter alia*, the creation of the abovementioned classes of share capital; the authority of the directors of IGL to enter into the DLC Agreements and the implementation of the DLC Structure are included in the notice convening the IGL general meeting, which is attached to and forms part of this circular.

Investec PLC will be headquartered in London and IGL and Investec as a whole will be headquartered in Sandton, South Africa.

4.9 Listing of Investec PLC and the proposed Investec PLC capital raising

4.9.1 Listing of Investec PLC

The secondary listing of Investec PLC ordinary shares in the Financials – “Speciality & Other Finance” sector of the JSE lists will be effective with effect from the commencement of business (09:00) on Monday, 22 July 2002, on which date it is expected that the conditional trading of new Investec PLC ordinary shares to be issued pursuant to the Investec PLC capital raising will also commence on the London Stock Exchange at the commencement of business (08:00 London time). The admission of Investec PLC's ordinary shares to the UKLA's Official List and admission to unconditional trading in Investec PLC ordinary shares on the London Stock Exchange is expected to be effective from the commencement of business (08:00 London time) on Monday, 29 July 2002. Investec PLC and IGL have agreed that in a discrepancy between the rules of the JSE and the London Stock Exchange, Investec PLC and IGL will apply the rule most beneficial to shareholders, expected to be the more stringent rule.

4.9.2 Trading in Investec PLC ordinary shares

Investec PLC will have its principal register of shareholders in the UK in respect of its primary listing on the London Stock Exchange, trading in respect of which will be in pounds sterling and a branch register in South Africa in respect of its secondary listing on the JSE, trading in respect of which will be in Rand.

Investec PLC shareholders who are South African residents and who hold shares on the South African branch register may only deal in their Investec PLC ordinary shares and/or acquire Investec PLC ordinary shares on that register unless they make use of the offshore allowance permitted by the SARB in order to trade their Investec PLC ordinary shares on the principal register.

4.9.3 The proposed Investec PLC capital raising

In conjunction with the listing of Investec PLC ordinary shares on the London Stock Exchange and on the JSE, it is proposed, subject to prevailing market conditions, that Investec PLC raise capital by way of an issue of up to 10 million new Investec PLC ordinary shares. At the request of the JSE, the approval of IGL members is sought for the proposed Investec PLC capital raising as though it were a specific issue of shares for cash. Accordingly, the resolution required to give effect to the proposed PLC capital raising is included as a resolution for a specific issue of shares for cash, which resolution is included in the notice convening the IGL meeting which is attached to and forms part of this circular.

The exact amount that is raised and the price at which the new Investec PLC ordinary shares will be issued will be established through an international bookbuilding exercise, having regard to market conditions which will result in the issue price of the new Investec PLC ordinary shares being determined by investor demand. Details of the final issue price of the new Investec PLC ordinary shares as well as the number of new Investec PLC ordinary shares will be announced as and when available. Application will be made to the JSE for the listing of the new Investec PLC ordinary shares. It is expected that the new Investec PLC ordinary shares will be listed on the JSE on Admission which is expected to be effective from the commencement of business (08:00 London time) on Monday, 29 July 2002.

The listing particulars to be issued in connection with the listing of Investec PLC ordinary shares on the London Stock Exchange and the proposed Investec PLC capital raising are expected to be published on or around 29 July 2002. IGL members (including Inhold members who receive IGL ordinary shares distributed pursuant to the Inhold unbundling) registered as such on Friday, 26 July 2002, will receive a copy of the Final Offering Circular relating to Investec PLC which will be made available for information purposes only.

4.10 IGL employee ownership schemes, the Investec PLC employee share plans and the Investec PLC employee trusts

At the core of Investec's culture is the concept that share ownership should be spread as widely as practicably possible among its employees. IGL operates the IGL share scheme and certain option schemes in the United Kingdom and has arranged two further schemes, Fintique II and Fintique III. The continuing rights under the aforementioned schemes, the adoption of the IGL 2002 scheme and the Investec PLC 2002 schemes and salient features of all the aforementioned and how they are affected by the transactions referred to in this circular are described in Annexure XV to this circular.

The resolution to adopt the IGL 2002 scheme and to approve and ratify the Investec PLC employee share plans and Investec PLC employee trusts is included in the notice convening the IGL general meeting attached to and forming part of this circular.

5. FINANCIAL INFORMATION RELATING TO INHOLD

5.1 Financial information relating to Inhold

The following financial information relating to Inhold is included in this circular:

- Annexure II to this circular contains historic financial information relating to Inhold;
- Annexure III to this circular contains the published audited results of Inhold for the financial year ended 31 March 2002;
- Annexure IV to this circular contains pro forma financial information relating to Inhold subsequent to the Inhold reorganisation, the Inhold unbundling and the Inhold winding-up; and
- Annexure V to this circular contains the reporting accountants' report on the pro forma financial information relating to Inhold.

Following the Inhold unbundling, Inhold members will hold their proportionate share of Inhold's investment in IGL directly. In this regard Inhold members are referred to financial information relating to IGL in paragraph 6.1 below.

5.2 Share capital of Inhold

The share capital of Inhold at Friday, 31 May 2002, being the last practicable date prior to the finalisation of this circular, is set out below:

	R'000
Authorised before the Inhold reorganisation	
100 000 000 Ordinary shares of 10 cents each	10 000
25 000 Cumulative redeemable preference shares of 50 cents each	13
Total authorised capital	10 013
Issued before the Inhold reorganisation	
37 015 295 Ordinary shares of 10 cents each	889 182
Nominal value	3 702
Share premium	885 480
800 Cumulative redeemable preference shares of 50 cents each	382 000
Nominal value	1
Share premium	381 999
Total issued capital	1 271 182
Authorised after the Inhold reorganisation	
100 000 000 Ordinary shares of 10 cents each	10 000
25 000 Cumulative redeemable preference shares of 50 cents each	13
Total authorised capital	10 013
Issued after the Inhold reorganisation	
37 015 295 Ordinary shares of 10 cents each	889 182
Nominal value	3 702
Share premium	885 480
– Cumulative redeemable preference shares of 50 cents each	–
Total issued capital	889 182

Inhold members are referred to paragraph 4.1.1 above for details regarding the redemption of the cumulative redeemable preference shares. There will be no other changes in the authorised and issued share capital of Inhold as a result of the Inhold reorganisation.

5.3 Material changes in Inhold

There have been no material changes in the financial or trading position of Inhold since 31 March 2002, being the date of Inhold's last financial year end, and the date of issue of this circular, other than as set out in this circular.

6. FINANCIAL INFORMATION RELATING TO IGL

6.1 Financial information relating to IGL

The following financial information is included in this circular in respect of IGL:

Annexure VI to this circular contains:

- the consolidated balance sheets of IGL at 31 March 2001 and 31 March 2000;
- the consolidated income statements of IGL for the financial years ended 31 March 2001 and 31 March 2000;
- the consolidated cash flow statements of IGL for the financial years ended 31 March 2001 and 31 March 2000;
- the statement of changes in shareholders' funds of IGL for the financial years ended 31 March 2001 and 31 March 2000; and
- the accounting policies of IGL.

Annexure VII to this circular contains the published audited results of IGL for the financial year ended 31 March 2002.

Annexure VIII to this circular contains pro forma financial information of IGL and Investec PLC after the IGL reorganisation, the IGL internal restructure, the IGL capital restructure, the IGL unbundling and the implementation of the DLC Structure.

Annexure IX to this circular contains the reporting accountants' report on the pro forma financial information relating to IGL and Investec PLC.

6.2 Share capital of IGL

The share capital of IGL at Friday, 31 May 2002, being the last practicable date prior to the finalisation of this circular, is set out below:

		R'000
Authorised before the IGL reorganisation and the IGL capital restructure		
150 000 000	Ordinary shares of 60 cents each	90 000
10 000 000	Class "A" variable rate compulsorily convertible non-cumulative preference shares of 60 cents each	6 000
50 000	Variable rate redeemable cumulative preference shares of 60 cents each	30
Total authorised capital		96 030
Issued before the IGL reorganisation and the IGL capital restructure		
92 281 158	Ordinary shares of 60 cents each	6 950 730
	Nominal value	55 369
	Share premium	6 895 361
2 000 000	Class "A" variable rate compulsorily convertible non-cumulative preference shares of 60 cents each	460 000
	Nominal value	1 200
	Share premium	458 800
Total issued equity capital		7 410 730
1 860 000	Class "A" variable rate unsecured subordinated compulsorily convertible debentures of 60 cents each	379 400
	Nominal value	1 116
	Share premium	378 284
Total issued capital and convertible debentures		7 790 130
		R'000
Authorised after the IGL reorganisation and before the IGL capital restructure		
150 000 000	Ordinary shares of 60 cents each	90 000
10 000 000	Class "A" variable rate compulsorily convertible non-cumulative preference shares of 60 cents each	6 000
50 000	Variable rate redeemable cumulative preference shares of 60 cents each	30
Total authorised capital		96 030
Issued after the IGL reorganisation and before the IGL capital restructure		
103 781 158 ¹	Ordinary shares of 60 cents each	9 070 730
	Nominal value	62 269
	Share premium	9 008 461
Total issued equity capital		9 070 730
1 860 000	Class "A" variable rate unsecured subordinated compulsorily convertible debentures of 60 cents each	379 400
	Nominal value	1 116
	Share premium	378 284
Total issued capital and convertible debentures		9 450 130

¹Includes the issue of 2 000 000 IGL ordinary shares on the conversion of the IGL convertible preference shares and 9 500 000 IGL ordinary shares on the acquisition of compulsory convertible debentures from Investec Bank as described in paragraph 4.2 above.

		R'000
Authorised after the IGL reorganisation and after the IGL capital restructure		
55 500 000	Ordinary shares of 0.1 cent each	56
10 000 000	Class "A" variable rate compulsorily convertible non-cumulative preference shares of 60 cents each	6 000
50 000	Variable rate redeemable cumulative preference shares of 60 cents each	30
1	Redeemable preference share with a par value of R1,00 (SA DAS Share)	–
1	Redeemable preference share with a par value of R1,00 (SA DAN Share)	–
112 000 000	Convertible redeemable preference shares with a par value of R0,001 each (IGL Special Converting Shares)	112
Total authorised capital		6 198
Issued after the IGL reorganisation and after the IGL capital restructure		
38 399 028	Ordinary shares of 0,1 cent each	9 008 499
	Nominal value	38
	Share premium	9 008 461
1	Redeemable preference share with a par value of R1,00 (SA DAS Share)	–
1	Redeemable preference share with a par value of R1,00 (SA DAN Share)	–
70 633 746 ²	Convertible redeemable preference shares with a par value of R0,001 each (IGL Special Converting Shares)	71
Total issued equity capital		9 008 570
1 860 000	Class "A" variable rate unsecured subordinated compulsorily convertible debentures of 60 cents each	379 400
	Nominal value	1 116
	Share premium	378 284
Total issued capital and convertible debentures		9 387 970

² IGL Special Converting Shares at the date of this circular are comprised of 70 633 746 IGL Special Converting Shares issued to mirror the number of Investec PLC ordinary shares in issue subsequent to the IGL internal restructure as set out in paragraph 6.4 below.

6.3 Material changes in IGL

There have been no material changes in the financial or trading position of IGL since 31 March 2002, being the date of IGL's last financial year end and the date of issue of this circular other than as set out in this circular.

6.4 Share capital of Investec PLC

Authorised after the IGL internal restructure		£'000
112 000 000	Ordinary shares of £0.001 each	112
Total authorised share capital		112
Issued after the IGL internal restructure		£'000
70 633 746	Ordinary shares of £0.001 each	71
Total issued share capital		71
Authorised after the IGL unbundling		£'000
112 000 000	Ordinary shares of £0.001 each	112
55 500 000	Investec PLC Special Converting Shares of £0.001 each	56
1	Investec PLC Special Voting Share of £0.001 each	–
1	UK DAN Share of £0.001	–
1	UK DAS Share of £0.001	–
Total authorised share capital		168

Issued after the IGL unbundling		£'000
70 633 746	Ordinary shares of £0.001 each	71
38 399 028 ³	Investec PLC Special Converting Shares of £0.001 each	38
1	Investec PLC Special Voting Share of £0.001 each	–
1	UKDAN Share of £0.001	–
1	UKDAS Share of £0.001	–
Total issued share capital		109

³ The Investec PLC Special Converting Shares in issue will mirror the number of ordinary shares in issue in IGL.

7. TAXATION CONSIDERATIONS

The statements set out below are based on current South African tax law and SARS practice. They are intended only as a general guide to current South African resident Inhold members and IGL members and are not intended to be, nor should they be considered to be, legal or tax advice to any such member. All Inhold members and all IGL members are referred to the section on stamp duty in paragraph 7.4 below. The tax treatment of Inhold members and IGL members whose taxation positions are not determined exclusively by South African legislation is dependent, *inter alia*, on the tax jurisdiction applicable to such members, although a general guide on the UK tax considerations of the Inhold unbundling and the IGL unbundling for UK resident Inhold members and UK resident IGL members (which is based on current UK tax law and UK Inland Revenue practice) is set out below. Inhold members and IGL members are advised to seek appropriate professional advice regarding their taxation positions.

7.1 South African taxation considerations of the Inhold unbundling

The distribution by Inhold of the IGL ordinary shares to Inhold members has been approved in principle by the Commissioner for the South African Revenue Service as an unbundling transaction in terms of section 60 of the unbundling legislation. Accordingly, no Secondary Tax on Companies is payable by Inhold in respect of the Inhold distribution.

The income tax and capital gains tax consequences of the Inhold distribution for South African resident members are as follows:

- where the recipients of the IGL ordinary shares hold their Inhold ordinary shares as capital assets:
 - a portion of the IGL ordinary shares received will constitute a dividend which will be exempt from tax in the member's hands; and
 - a portion of the IGL ordinary shares received will constitute a capital distribution, which will be exempt from tax, but which will reduce each member's base cost for capital gains tax purposes of his Inhold ordinary shares;
 - the abovementioned dividend portion and capital distribution portion as well as the base cost for capital gains tax purposes of each IGL ordinary share received by an Inhold member are still subject to final determination and a further announcement in this regard will be made to Inhold members as soon as such amounts have been determined;
 - on the subsequent liquidation of Inhold, each Inhold member will realise a capital loss equal to his base cost of his Inhold ordinary shares (as reduced by the above capital distribution);
 - for the purposes of section 9B of the Income Tax Act, the Inhold member's Inhold ordinary shares and IGL ordinary shares shall be deemed to be the same shares; and
 - the effect of the IGL unbundling is explained in paragraph 7.3 below;
- where the recipients of the IGL ordinary shares hold the Inhold ordinary shares as trading stock, the receipt by them of the IGL ordinary shares will be dealt with in a tax neutral manner in accordance with the provisions of section 60(5)(b) of the unbundling legislation and, more particularly:
 - an Inhold qualifying member who held Inhold ordinary shares as trading stock will for the purpose of section 22(1) of the Income Tax Act, be deemed to have acquired Inhold ordinary shares and IGL ordinary shares at a cost equal to the cost to him of Inhold ordinary shares or where such person is not a company, the lesser of such cost to him or the diminished value of Inhold ordinary shares as contemplated in that section;
 - a portion of such cost will be apportioned to IGL ordinary shares, which portion will be deemed to be an amount which bears to such cost the same ratio as the market value of IGL ordinary shares bears to the market value of Inhold ordinary shares;
 - the provisions of section 22(4) of the Income Tax Act will be deemed not to apply to IGL ordinary shares;

- Inhold ordinary shares and IGL ordinary shares will for the purpose of section 9B and 24A of the Income Tax Act be deemed to be the same shares;
- where recipients of the IGL ordinary shares held their Inhold ordinary shares on the record date for the Inhold unbundling as a result of a right contemplated in section 8A of the Income Tax Act, such shares will be dealt with in a tax neutral manner, as set out in section 60(5)(c) of the unbundling legislation.

7.2 South African taxation considerations of the IGL capital restructure

The IGL capital restructure will have no South African tax consequences for current IGL members. In terms of paragraph 78(2) of the 8th schedule of the Income Tax Act any capital gain or loss determined in respect of the split and the cancellation of shares must be disregarded, and the new shares issued in substitution for the old shares must have an aggregate base cost equal to that of the old shares, allocated amongst such new shares in proportion to their market values.

7.3 South African taxation considerations of the IGL unbundling and the implementation of the DLC Structure

The distribution by IGL of the Investec PLC ordinary shares to IGL members has been approved in principle by the Commissioner for SARS as an unbundling transaction in terms of section 60 of the unbundling legislation. Accordingly, no Secondary Tax on Companies is payable by IGL in respect of the IGL distribution.

Note: The taxation considerations set out below will also apply to an existing Inhold member's receipt of IGL ordinary shares in terms of the Inhold unbundling if such member is registered in the IGL register of members on the record date for the IGL unbundling.

The income tax and capital gains tax consequences of the IGL distribution and the implementation of the DLC Structure for South African resident members are as follows:

- where the recipients of the Investec PLC ordinary shares hold their IGL ordinary shares as capital assets:
 - a portion of the Investec PLC ordinary shares received will constitute a dividend which will be exempt from tax in the member's hands; and
 - a portion of the Investec PLC ordinary shares received will constitute a capital distribution, which will be exempt from tax, but which will reduce each member's base cost for capital gains tax purposes of his IGL ordinary shares;
- the abovementioned dividend portion and capital distribution portion as well as the base cost for capital gains tax purposes of each Investec PLC ordinary share received by an IGL member are still subject to final determination and a further announcement in this regard will be made to IGL members as soon as such amounts have been determined; and
- for the purposes of section 9B of the Income Tax Act, the IGL member's IGL ordinary shares and Investec PLC ordinary shares shall be deemed to be the same shares;
- where the recipients of the Investec PLC ordinary shares hold the IGL ordinary shares as trading stock, the receipt by them of the relevant Investec PLC ordinary shares will be dealt with in a tax neutral manner in accordance with the provisions of section 60(5)(b) of the unbundling legislation and, more particularly:
 - an IGL qualifying member who held IGL ordinary shares as trading stock will for the purpose of section 22(1) of the Income Tax Act, be deemed to have acquired IGL ordinary shares and Investec PLC ordinary shares at a cost equal to the cost to him of IGL ordinary shares, or where such person is not a company, the lesser of such cost to him or the diminished value of IGL ordinary shares as contemplated in that section;
 - a portion of such cost shall be apportioned to Investec PLC ordinary shares, which portion will be deemed to be an amount which bears to such cost the same ratio as the market value of IGL ordinary shares bears to the market value of Investec PLC ordinary shares;
 - the provisions of section 22(4) of the Income Tax Act will be deemed not to apply to Investec PLC ordinary shares;
 - IGL and Investec PLC ordinary shares will for the purpose of section 9B and 24A of the Income Tax Act be deemed to be the same shares;
- where recipients of the Investec PLC ordinary shares held their IGL shares on the record date for the IGL unbundling as a result of a right contemplated in section 8A of the Income Tax Act, such shares will be dealt with in a tax neutral manner, as set out in section 60(5)(c) of the unbundling legislation;

- given the current shareholding of IGL and the corresponding initial shareholding of Investec PLC, the latter will not initially constitute a controlled foreign entity as defined in section 9D of the Income Tax Act;
- the issue of the IGL Special Converting Shares and the Dividend Access Shares will have no immediate South African tax consequences for current IGL members;
- a future conversion of the Investec PLC Special Converting Shares on termination will not constitute a capital gains tax event. It will, however, have an impact on the base cost of the original share and the new ordinary share acquired on conversion;
- to the extent that dividends declared in respect of the Investec PLC ordinary shares and Dividend Access Shares are sourced out of profits generated in designated countries (as defined in section 9E of the Income Tax Act) which are taxable in the UK at a statutory rate of at least 27%, they will be exempt from South African tax and will give rise to corresponding Secondary Tax on Companies credits for corporate shareholders. This is in terms of either section 9E(7)(c) of the Income Tax Act (for shareholders who together with connected persons hold less than 10% of Investec PLC's equity share capital) or section 9E(7)(d) of the Income Tax Act (for shareholders who directly hold at least 10% of Investec PLC's equity share capital). It is Investec PLC's intention to meet the requirements for these exemptions to the extent possible. Should the dividends be declared in circumstances which do not qualify for the exemption, shareholders will be advised accordingly.

7.4 Stamp duty

7.4.1 South African stamp duty implications of the Inhold unbundling

The registration of the transfer of the IGL ordinary shares into the names of the Inhold qualifying members will be exempt from South African stamp duty.

7.4.2 South African stamp duty implications of the IGL unbundling

The registration of the transfer of the Investec PLC ordinary shares into the names of IGL qualifying members will be exempt from South African stamp duty.

7.4.3 UK stamp duty and stamp duty reserve tax ("SDRT")

The transfer of the Investec PLC ordinary shares to IGL qualifying members should be exempt from UK stamp duty and SDRT, whether such transfer is registered on the UK principal register or the South African branch register of Investec PLC.

Transfers of shares in a UK incorporated company into a clearance service can in certain circumstances attract UK stamp duty or SDRT at the rate of 1.5%. It is possible that STRATE could constitute a clearance certificate for this purpose. However, following correspondence between STRATE and the UK Inland Revenue, the UK Inland Revenue have confirmed that, subject to limited conditions, transfers of shares in a UK incorporated company into STRATE will not be subject to this 1.5% charge. Accordingly, therefore, to the extent that Investec PLC ordinary shares are distributed to IGL qualifying members on the IGL unbundling (in dematerialised form) within STRATE, no such charge should arise.

7.5 Taxation considerations for non-South African resident members

Non-resident members of Inhold and IGL are advised to consult their professional advisers as regards the tax treatment of the Inhold unbundling or the IGL capital restructure and the IGL unbundling, as the case may be, in the light of their own circumstances.

In particular, Inhold members or IGL members who are resident for tax purposes in the UK should note that the distribution by Inhold of the IGL ordinary shares in terms of the Inhold unbundling or the distribution by IGL of the Investec PLC ordinary shares on the IGL unbundling, as the case may be, may constitute a taxable event for UK tax purposes. UK resident Inhold members or IGL members are advised to seek their own advice.

8. EXCHANGE CONTROL CONSIDERATIONS

8.1 Inhold members and IGL members resident in the US, Canada, Australia or Japan

Inhold members and IGL members with addresses in the US, Canada, Australia or Japan shall not be entitled to receive IGL ordinary shares in terms of the Inhold unbundling or Investec PLC ordinary shares in terms of the IGL unbundling, but their entitlements to such shares will be sold on the JSE or London Stock Exchange and such

members will receive cash equal to the proceeds (after deducting the realisation and associated administrative costs thereof) derived from a sale of such members' entitlement to the IGL ordinary shares or the Investec PLC ordinary shares, as the case may be, unless such members provide written proof to the satisfaction of the directors of Inhold or the directors of IGL, as the case may be, that they are entitled to receive a distribution of the IGL ordinary shares or the Investec PLC ordinary shares, as the case may be, under the laws of the US, Canada, Australia or Japan, as the case may be.

Inhold members and IGL members are requested to note that the guidelines in paragraphs 8.2 – 8.5 below are not a comprehensive statement of the Exchange Control Regulations of South Africa and they reflect Inhold's and IGL's directors' understanding of the regulations at the date of this circular. Accordingly, they are not intended to be, nor should they be considered to be, advice to such members in terms of the Exchange Control Regulations of South Africa and Inhold members and IGL members should consult their professional advisers to remove any uncertainties.

8.2 Residents of the common monetary area

8.2.1 Implications of the Inhold unbundling

In the case of an Inhold member whose registered address in the Inhold register of members is within the common monetary area, a new IGL certificate or share statement, as the case may be, in respect of such Inhold members' entitlement to IGL ordinary shares, will be mailed by registered or ordinary post, respectively, to the Inhold member concerned and for by certificated Inhold members this will occur upon the surrender of the existing Inhold ordinary share certificates in accordance with paragraph 9 below.

8.2.2 Implications of the IGL unbundling

In the case of an Inhold member (who becomes an IGL member pursuant to the Inhold unbundling) or an IGL member whose registered address in the IGL register of members is within the common monetary area, a new Investec PLC certificate or share statement, as the case may be, in respect of such Inhold member's or IGL member's entitlement to Investec PLC ordinary shares, will be mailed by registered or ordinary post, respectively, to the Inhold member or IGL member concerned and for certificated Inhold members or certificated IGL members this will occur upon the surrender of the existing Inhold ordinary share certificates or the existing IGL ordinary share certificates, in accordance with paragraph 9 below.

8.2.3 Implications of the IGL capital restructure and the IGL name change

In the case of an Inhold member (who becomes an IGL member pursuant to the Inhold unbundling) or an IGL member whose registered address in the Inhold register of members or the IGL register of members is within the common monetary area, a new IGL ordinary share certificate or share statement, as the case may be, will be mailed by registered or ordinary post, respectively, to the Inhold member or IGL member concerned and for certificated Inhold members or certificated IGL members this will occur upon the surrender of the existing Inhold ordinary share certificates or IGL ordinary share certificates, in accordance with paragraph 9 below.

8.3 Non-residents who are emigrants from the common monetary area

8.3.1 Implications of the Inhold unbundling

In the case of an Inhold member who is an emigrant from a country within the common monetary area and whose documents of title in respect of his existing Inhold ordinary shares are restrictively adorsed in terms of the South African Exchange Control Regulations, a new IGL ordinary share certificate or share statement, as the case may be, bearing a "non-resident" endorsement will be posted to the authorised dealer controlling such emigrant's blocked assets and for certificated Inhold members this will occur upon the surrender of the existing Inhold ordinary share certificates in accordance with paragraph 9 below. In terms of the Exchange Control Regulations of South Africa, the IGL ordinary shares so received are not freely transferable from the common monetary area. The CSDP or broker holding the electronic record of ownership for dematerialised Inhold members in respect of their Inhold ordinary shares will be responsible for ensuring that the relevant requirements of the South African Exchange Control Regulations are adhered to.

8.3.2 Implications of the IGL unbundling

In the case of an Inhold member (who becomes an IGL member pursuant to the Inhold unbundling) or an IGL member who acquires Investec PLC ordinary shares in terms of the IGL unbundling who is an emigrant from a country within the common monetary area and whose documents of title in respect of his existing Inhold ordinary shares or existing IGL ordinary shares are restrictively endorsed in terms of the South African Exchange Control Regulations, his entitlement to Investec PLC ordinary shares will be registered on the branch register in the name of a nominee resident in, and with an address in South Africa and if such nominee is not submitted by the IGL member (or Inhold member who becomes an IGL member pursuant to the Inhold unbundling) in writing within 4 days after the record date for the IGL unbundling, the nominee and address will be nominated by Investec PLC. The new Investec PLC share certificates or share statements, as the case may be, in respect of such Investec PLC ordinary shares will, in accordance with paragraph 4.7.2.8, be forwarded to the South African authorised dealer controlling the blocked assets of that emigrant member; if such authorised dealer is nominated in writing within 4 days after the record date for the IGL unbundling, failing which an authorised dealer will be nominated by Investec PLC. For certificated Inhold members and certificated IGL members the forwarding of Investec PLC share certificates or share statements, as the case may be, will occur upon the surrender of the existing Inhold ordinary share certificates or IGL ordinary share certificates in accordance with paragraph 9 below.

8.3.3 Implications of the IGL capital restructure and the IGL name change

In the case of an Inhold member (who becomes an IGL member pursuant and to the Inhold unbundling) or an IGL member who is an emigrant from a country within the common monetary area and whose documents of title in respect of his existing Inhold ordinary shares or existing IGL ordinary shares are restrictively endorsed in terms of the South African Exchange Control Regulations, a new IGL ordinary share certificate or share statement, as the case may be, which will be restrictively endorsed in terms of the South African Exchange Control Regulations, will be posted to the authorised dealer in foreign exchange in South Africa controlling such emigrant's blocked assets, and for certificated Inhold members or certificated IGL members this will occur upon surrender of their existing Inhold ordinary share certificates or the existing IGL ordinary share certificates, in accordance with paragraph 9 below. The CSDP or broker holding the electronic record of ownership for dematerialised Inhold members (who become dematerialised IGL members pursuant to the Inhold unbundling), dematerialised IGL members in respect of their IGL ordinary shares will be responsible for ensuring that the relevant requirements of the South African Exchange Control Regulations are adhered to.

In respect of non-residents who are emigrants from the common monetary area, any cash proceeds, net of realisation and associated costs, pursuant to a sale in terms of 8.1 above, which are due to an Inhold member or an IGL member who is an emigrant from South Africa, whose registered address in Inhold's register of members or IGL's register of members, as the case may be, is outside the common monetary area, and whose documents of title have been restrictively endorsed under the Exchange Control Regulations of South Africa, will be deposited in such member's blocked account with the authorised dealer in South Africa controlling such member's blocked assets. The aforesaid proceeds are not freely transferable from South Africa and may only be dealt with in terms of the Exchange Control Regulations of South Africa.

8.4 All other non-residents of the common monetary area

8.4.1 Implications of the Inhold unbundling

In the case of an Inhold member who is a non-resident of the common monetary area, who has never resided in the common monetary area, whose registered address is outside the common monetary area and whose documents of title have been restrictively endorsed "non-resident" under the Exchange Control Regulations of South Africa, a new IGL ordinary share certificate or share statement, as the case may be, will be issued which will be endorsed "non-resident" and for certificated Inhold members this will occur upon the surrender of the existing Inhold ordinary share certificates in accordance with paragraph 9 below. The CSDP or broker holding the electronic record of ownership for dematerialised Inhold members in respect of their Inhold ordinary shares will be responsible for ensuring that the relevant requirements of the South African Exchange Control Regulations are adhered to.

8.4.2 Implications of the IGL unbundling

In the case of an Inhold member (who becomes an IGL member pursuant to the Inhold unbundling) or an IGL member who acquires Investec PLC shares in terms of the IGL unbundling and had on the record date for the IGL unbundling, a registered address in the register of members of IGL outside the common monetary area and who is not an emigrant from a country within the common monetary area subject to the provisions of paragraph 8.3.2 above, will have his entitlement to Investec PLC ordinary shares registered on the principal register in his name and with such address, free from any control in terms of the South African Exchange Control Regulations and the new Investec PLC share certificate or share statement, as the case may be, shall be dealt with in accordance with the provisions of paragraph 4.7.2.7 above and for certificated Inhold members and certificated IGL members this will occur upon the surrender of the existing Inhold share certificates or the existing IGL share certificates.

8.4.3 Implications of the IGL capital restructure and the IGL name change

In the case of an Inhold member (who becomes an IGL member pursuant to the Inhold unbundling) or an IGL member who had on the record date for the IGL capital restructure, a registered address in the register of members of IGL outside the common monetary area and who is not an emigrant from a country within the common monetary area subject to the provisions of paragraph 8.3.3 above, the new IGL ordinary share certificate or share statement, as the case may be, to be issued will be endorsed "non-resident", and for certificated Inhold members or certificated IGL members this will occur upon the surrender of the existing Inhold share certificates or the existing IGL ordinary share certificates in accordance with paragraph 9 below. The CSDP or broker holding the electronic record of ownership for dematerialised Inhold members (who become dematerialised IGL members pursuant to the Inhold unbundling) or dematerialised IGL members in respect of their IGL ordinary shares will be responsible for ensuring that the relevant requirements of the South African Exchange Control Regulations are adhered to.

Any cash proceeds, net of realisation and associated costs, pursuant to a sale in terms of 8.1 above, which is due to an Inhold member, or an IGL member, as the case may be, who is a non-resident of the common monetary area, who has never resided in the common monetary area, whose registered address is outside the common monetary area and whose documents of title have been restrictively endorsed under the Exchange Control Regulations of South Africa, will be deposited in such member's non-resident account with an authorised bank. It will be incumbent upon such non-resident member concerned to instruct such authorised bank as to how to direct such funds.

8.5 Summary of the South African Exchange Control Regulations relating to the receipt of Investec PLC shares

In accordance with the Exchange Control Regulations applicable to all countries within the common monetary area and taking into account the provisions of the UK Companies Act governing the operation of the share register of Investec PLC, an Inhold member (who becomes an IGL member pursuant to the Inhold unbundling) or an IGL member acquiring Investec PLC ordinary shares in terms of the IGL unbundling, who:

- (a) *had on the record date for the IGL unbundling, in the register of members of IGL, whether as the beneficial holder or through a nominee, a registered address in the common monetary area within:*
 - (i) *South Africa, will have his entitlement to Investec PLC ordinary shares registered in the branch register in his name or the name of his nominee, as appropriate, with his South African address;*
 - (ii) *The Republic of Namibia or the Kingdoms of Lesotho or Swaziland, will have his entitlement to Investec PLC ordinary shares registered on the branch register in the name of a nominee resident in, and with an address in, South Africa and if such nominee and address are not submitted by the IGL member (or Inhold member who becomes an IGL member pursuant to the Inhold unbundling), in writing within 4 days after the record date for the IGL unbundling, the nominee and address will be nominated by Investec PLC;*
- (b) *is an emigrant from a country within the common monetary area and whose documents of title in respect of his existing Inhold ordinary shares or existing IGL ordinary shares are restrictively endorsed in terms of the South African Exchange Control Regulations, will have his entitlement to Investec PLC ordinary shares registered on the branch register in the name of a nominee resident in, and with an address in South Africa and if such nominee and address are not submitted by the IGL member (or Inhold member who becomes an IGL member pursuant to the Inhold unbundling) in writing within 4 days after the record date for the IGL unbundling, the nominee and address will be nominated by Investec PLC. The new Investec PLC share*

certificate or share statement, as the case may be, in respect of such Investec PLC ordinary shares will, in accordance with the provisions of paragraph 4.7.2.8 be forwarded to the South African authorised dealer controlling the blocked assets of that emigrant member; if such authorised dealer is nominated in writing within 4 days after the record date for the IGL unbundling, failing which an authorised dealer will be nominated by Investec PLC;

- (c) *had on the record date for the IGL unbundling, a registered address in the register of members of IGL outside the common monetary area and who is not an emigrant from a country within the common monetary area subject to the provisions of (b), will have his entitlement to Investec PLC ordinary shares registered on the principal register in his name and with such address, free from any control in terms of the South African Exchange Control Regulations and the new Investec PLC share certificate or share statement, as the case may be, in respect of such Investec PLC ordinary shares shall be dealt with in accordance with the provisions of paragraph 4.7.2.7.*

After the Inhold unbundling and the IGL unbundling, Investec PLC shareholders who are non-South African residents and who hold shares on the branch register through South African nominees, who wish to reregister their holdings into their own names or to remove their registrations from the branch register to the principal register (either into their own names or into the name of a non-South African nominee), including those who wish to hold their shares in Investec PLC, in CREST (being the electronic settlement system in the UK used to facilitate the transfer of title to shares in uncertificated form on the London Stock Exchange, which will be available in respect of certain Investec PLC ordinary shares) will require SARB consent to do so, for which purpose they should approach the exchange control division of a commercial bank in South Africa.

New non-South African resident investors in shares in Investec PLC who wish to hold shares on the branch register will need to appoint a South African resident nominee. In the case of non-common monetary area residents, the appointment of such nominee must be referred to the exchange control division of an authorised dealer in South Africa.

9. PROCEDURE FOR THE SURRENDER OF INHOLD SHARE CERTIFICATES AND IGL SHARE CERTIFICATES

- 9.1** In order to give effect to the transactions, it will be necessary to recall all certificated Inhold ordinary shares and all certificated IGL ordinary shares in issue. Certificated Inhold members and certificated IGL members who wish to anticipate the Inhold unbundling and the IGL capital restructure, the IGL unbundling and the IGL name change and who do not wish to deal in their existing Inhold ordinary shares or their existing IGL ordinary shares, as the case may be, prior to the aforementioned transactions becoming effective, are requested to surrender their certificated Inhold ordinary shares or their certificated IGL ordinary shares to the transfer secretaries, namely, Computershare Investor Services Limited, 2nd Floor, Edura, 41 Fox Street, Johannesburg, 2001 (PO Box 61051, Marshalltown, 2107) in respect of Inhold ordinary shares or IGL ordinary shares listed on the JSE or the BSE, or, in the case of IGL ordinary shares listed on the NSX, to The Transfer Secretaries (Proprietary) Limited, Shop 12, Kaiserkrone Centre, Post Street Mall, Windhoek, Namibia (PO Box 2401, Windhoek, Namibia). Certificated Inhold ordinary shares and certificated IGL ordinary shares so received will be held in trust by the transfer secretaries pending the transactions becoming effective, failing which, the transfer secretaries will, within five business days thereafter, return the certificated Inhold ordinary shares or the certificated IGL ordinary shares to the certificated Inhold members or the certificated IGL members concerned, as the case may be, by registered post, at the risk of such certificated Inhold member or certificated IGL member.
- 9.2** The attention of certificated Inhold members and certificated IGL members is drawn to the fact that if they surrender their documents of title in advance, they will not be in a position to deal in their Inhold ordinary shares or their IGL ordinary shares on the JSE and, in the case of IGL ordinary shares, on the BSE and NSX between the date of such surrender and Monday, 29 July 2002.
- 9.3** All certificated Inhold members and certificated IGL members shall, unless otherwise stated, be entitled in respect of the IGL ordinary shares and the Investec PLC ordinary shares to be received by them pursuant to transactions:
- 9.3.1** to participate in an issuer-sponsored nominee programme and to have their IGL ordinary shares and Investec PLC ordinary shares held by the nominee in accordance with the nominee terms and conditions.
The issuer-sponsored nominee programme is not available to certificated Inhold members or certificated IGL members who are emigrants from and non-residents of the common monetary area; or

- 9.3.2** to appoint Computershare Custodial as their CSDP and to have their IGL ordinary shares or their Investec PLC ordinary shares held in their own name in the sub-register of members held by Computershare Custodial in accordance with custody terms and conditions; or
- 9.3.3** to elect to receive a new IGL share certificate and a new Investec PLC share certificate.
- 9.4** The attention of certificated Inhold members and certificated IGL members is drawn to the fact that should such members elect to receive a new IGL share certificate and a new Investec PLC share certificate, they will be required to dematerialise such shares prior to trading in them on the JSE and, in the case of IGL ordinary shares, this will also apply to trading on the BSE and the NSX. The dematerialisation process can take between 24 hours and 10 days, depending on the volumes being processed by STRATE at the time of the dematerialisation.
- 9.5** A second form of surrender will be sent to Inhold and IGL members together with the announcement of the results of the Inhold general meeting and the IGL general meeting.
- 9.6** The nominee terms and conditions and the custody terms and conditions relating to the issuer-sponsored nominee programme are set out in Annexure XVI and Annexure XVII, respectively. Those certificated Inhold members or certificated IGL members who wish to make the election referred to in paragraph 9.3.1 above, namely, to participate in the issuer-sponsored nominee programme and who are eligible to do so should, after reading and understanding the terms and conditions set out in Annexure XVI and Annexure XVII, respectively, tick the appropriate box [C(i)] on the applicable form of surrender to clearly indicate their instructions. That form together with their documents of title should be sent to, Computershare Investor Services Limited, 2nd Floor, Edura, 41 Fox Street, Johannesburg, 2001 (PO Box 61051, Marshalltown, 2107) in respect of Inhold ordinary shares or IGL ordinary shares listed on the JSE or the BSE or, in the case of IGL ordinary shares listed on the NSX, to The Transfer Secretaries (Proprietary) Limited, Shop 12, Kaiserkrone Centre, Post Street Mall, Windhoek, Namibia (PO Box 2401, Windhoek, Namibia).
- 9.7** Those certificated Inhold members or certificated IGL members who wish to make the election referred to in paragraph 9.3.2 above, namely, to appoint Computershare Custodial as their CSDP and to have their uncertificated IGL ordinary shares and Investec PLC ordinary shares held in their own name in the sub-register of members held by Computershare Custodial and who are eligible to do so should, after reading and understanding the terms and conditions set out in Annexure XVI tick the appropriate box [C(ii)] on the attached applicable form of surrender. That form, together with their documents of title should be sent to, Computershare Investor Services Limited, 2nd Floor, Edura House, 41 Fox Street, Johannesburg, 2001 (PO Box 61051, Marshalltown, 2107) in respect of Inhold ordinary shares or IGL ordinary shares listed on the JSE or the BSE, or, in the case of IGL ordinary shares listed on the NSX, to The Transfer Secretaries (Proprietary) Limited, Shop 12, Kaiserkrone Centre, Post Street Mall, Windhoek, Namibia (PO Box 2401, Windhoek, Namibia).
- 9.8** Certificated Inhold members or certificated IGL members who wish to receive a new IGL share certificate and new Investec PLC share certificate should complete the election and surrender and transfer form by ticking the appropriate box [C(iii)] and lodge such form together with their documents of title with to, Computershare Investor Services Limited, 2nd Floor, Edura, 41 Fox Street, Johannesburg, 2001 (PO Box 61051, Marshalltown, 2107) in respect of Inhold ordinary shares and IGL ordinary shares listed on the JSE or the BSE, or, in the case of IGL ordinary shares listed on the NSX to The Transfer Secretaries (Proprietary) Limited, Shop 12, Kaiserkrone Centre, Post Street Mall, Windhoek, Namibia (PO Box 2401, Windhoek, Namibia). It should be noted that IGL members who hold their IGL ordinary shares on the BSE and NSX will, subject to the surrender of their existing documents of title in respect of their IGL ordinary shares, automatically receive new IGL share certificates and new Investec PLC share certificates in certificated form.
- Inhold members and IGL members are advised that they will be required to dematerialise such shares certificates in order to trade their IGL ordinary shares or Investec PLC ordinary shares, as the case may be, on the JSE and in the case of IGL ordinary shares, also the BSE and NSX. The dematerialisation process can take between 24 hours and 10 days, depending on the volumes being processed by STRATE at the time of dematerialisation.**
- 9.9** Share statements in respect of IGL and Investec PLC ordinary shares shall be posted to dematerialised Inhold members and dematerialised IGL members or certificated Inhold members and certificated IGL members who make the election referred to in paragraphs 9.3.1 and 9.3.2 above, by ordinary post on Monday, 29 July 2002 if documents of title have been surrendered by 17:00 on Friday, 26 July 2002 or within five business days of receipt by the transfer secretaries of the applicable form of surrender and the relevant documents of title.
- 9.10** Notwithstanding the provisions of paragraph 9.3 above, should an Inhold member or IGL member:
- not have surrendered his documents of title in respect of his holding of Inhold ordinary shares and/or IGL ordinary shares by Thursday, 25 July 2002 in the case of Inhold members or Friday, 26 July 2002 in the case of IGL members; or
 - failed to fully complete the applicable form of surrender to the satisfaction of the transfer secretaries in its sole and absolute discretion,

then that Inhold member's or IGL member's entitlement to IGL ordinary shares and Investec PLC ordinary shares shall be held in trust by Inhold or IGL, as the case may be, until surrender by such Inhold member or IGL member of his documents of title.

- 9.11** If documents of title have been lost or destroyed, and the Inhold member and/or IGL member concerned produces evidence to this effect to the satisfaction of the transfer secretaries, then the transfer secretaries may dispense with the surrender of such documents of title, for the purpose of enabling the Inhold member and/or IGL member to receive the IGL ordinary shares and Investec PLC ordinary shares, against provision of an indemnity acceptable to Inhold and/or IGL, provided that Inhold and/or IGL may in their discretion waive the provisions of such indemnity.

10. SUSPENSIVE CONDITIONS

The transactions are subject to final regulatory approval and the separate approval of the Inhold members and the IGL members, as the case may be.

11. LISTINGS

Subject to the fulfillment of the suspensive conditions the JSE has agreed to:

- suspension of Inhold from the JSE with effect from the commencement of business (09:00) on Friday, 19 July 2002 and the delisting of Inhold from the JSE with effect from the commencement of business (09:00) on Friday, 26 July 2002;
- the secondary listing of Investec PLC ordinary shares in the Financials – “Speciality & Other Finance” sector of the JSE lists under the abbreviated name “INP” with effect from the commencement of business (09:00) on Monday, 22 July 2002; and
- the continued listing of the IGL ordinary shares in the Financials – “Speciality & Other Finance” sector of the JSE lists under the abbreviated name “INL”, taking into account the IGL capital restructure and the IGL name change.

IGL will retain its existing secondary listing on the BSE and NSX.

12. MAJOR SHAREHOLDERS OF INHOLD AND IGL

12.1 Major shareholders of Inhold

At Friday, 31 May 2002, being the last practicable date prior to the finalisation of this circular, the following entities were the registered holders of 5% or more of the issued ordinary share capital of Inhold:

Registered shareholder	Number of Inhold ordinary shares	Percentage of issued ordinary share capital
Standard Bank Nominees (Tvl) (Proprietary) Limited	10 268 280	27,7
Ferbros Nominees (Proprietary) Limited	9 907 220	26,8
Old Mutual Nominees (Proprietary) Limited	5 543 183	15,0
Nedcor Bank Nominees Limited	3 958 968	10,7
Total	29 677 651	80,2

12.2 Major shareholders of IGL

At Friday, 31 May 2002, being the last practicable date prior to the finalisation of this circular, the following entities were the registered holders of 5% or more of the issued ordinary share capital of IGL:

Registered shareholder	Number of IGL ordinary shares	Percentage of issued ordinary share capital
Inhold	27 143 022	29,4
Nedcor Bank Nominees Limited	16 244 731	17,6
Standard Bank Nominees (Tvl) (Proprietary) Limited	14 327 340	15,5
Ferbros Nominees (Proprietary) Limited	6 691 920	7,3
ABSA Nominees (Proprietary) Limited	5 787 566	6,3
First National Nominees (Proprietary) Limited	5 460 440	5,9
CMB Nominees (Proprietary) Limited	5 243 121	5,7
Total	80 898 140	87,7

13. INHOLD DIRECTORS' INTERESTS

13.1 Directors' interests in Inhold ordinary shares

The beneficial and non-beneficial holdings of the directors of Inhold in its share capital (excluding holdings of Inhold directors which have been disclosed in paragraph 14.1 below) at Friday, 31 May 2002, are set out below:

Director	IGL		Inhold	
	IGL ordinary shares beneficially held (Note 1)	Indirect beneficial and non-beneficial call warrants† (Note 1)	Inhold ordinary shares beneficially held	Future entitlements to Inhold ordinary shares under employee ownership initiatives
Glynn R Burger	3 750	229 610	251 306	334 510

†Two year variable call warrants at a strike price of R145 per share.

Note 1 Beneficial interests include those of connected persons as defined in the Listing Rules of the UKLA.

A company in which Glynn R Burger owns 15.6% in an indirect beneficial capacity owns 3 817 900 Inhold ordinary shares and has a short position of 2 209 500 IGL ordinary shares which interest is not included above.

There have been no changes in the beneficial and non-beneficial holdings of the directors of Inhold in Inhold's share capital from 1 April 2002, being the start of IGL's current financial year, to Friday, 31 May 2002, being the last practicable date prior to the finalisation of this circular.

13.2 Inhold directors' interests in transactions

None of the directors of Inhold have any interest in any transactions which are or were unusual in their nature or conditions or significant to the business of Inhold and its subsidiaries, which were effected:

- during the current or immediately preceding financial years; or
- during an earlier financial period and which remain outstanding or unperformed.

14. IGL DIRECTORS AND DIRECTORS' INTERESTS

14.1 Directors' interests in IGL ordinary shares

The beneficial and non-beneficial holdings of the directors of IGL in the share capital of IGL and Inhold at Friday, 31 May 2002, being the last practicable date prior to the finalisation of this circular, are set out below:

Director	IGL		Inhold	
	IGL ordinary shares beneficially held (Note 1)	Indirect beneficial and non-beneficial call warrants† (Note 1)	Inhold ordinary shares beneficially held	Future entitlements to Inhold ordinary shares under employee ownership initiatives
Executive directors				
Stephen Koseff*	3 526	545 263	487 178	372 611
Bernard Kantor*	1 000	545 263	408 700	372 611
David M Lawrence	–	19 263	60 500	175 436
Bradley Tapnack	–	26 368	60 838	209 943
Non-executive directors				
Hugh S Herman*	2 500	42 763	139 250	361 344
Sam E Abrahams	–	2 105	–	20 937
Dr Hilton K Davies	918	–	4 189	–
Graham H Davin*	–	–	100	50 000
Donn E Jowell (Note 2)	–	3 158	–	135 000
Ian R Kantor	874	1 100 000	–	90 000
Daphne R Motsepe	–	–	–	–
Dr Morley Z Nkosi	–	–	–	–
Peter R S Thomas*	575	2 632	159 951	26 172

* The directors marked with an asterisk are also directors of Inhold.

† Two-year variable call warrants at a strike price of R145 per share.

Note 1 Beneficial interests include those of connected persons as defined in the Listing Rules of the UKLA.

Note 2 Donn E Jowell has a non-beneficial interest of 880 IGL ordinary shares.

A company in which Hugh S Herman, Stephen Koseff and Bernard Kantor own 7,6%, 38,4% and 38,4%, respectively, in an indirect beneficial capacity owns 3 817 900 Inhold ordinary shares and has a short position of 2 209 500 IGL ordinary shares, which interests are not included above.

In addition Bernard Kantor entered into a put and call option agreement with Investec Securities Limited on 30 November 2001 pursuant to which he is entitled to put 200 000 IGL ordinary shares at strike price of R225,00 and Investec Securities Limited are entitled to call 200 000 IGL ordinary shares at a strike price of R300,00. The expiry date for the exercise of this put and/or the call is 28 November 2003.

No share options have been issued to directors of IGL and they are at risk for shares issued under employee ownership initiatives.

There have been no changes in the beneficial and non-beneficial holdings of the directors of IGL in the share capital of IGL and Inhold from 1 April 2002, being the start of IGL's current financial year; to Friday, 31 May 2002, being the last practical date prior to the finalisation of this circular.

14.2 IGL directors' interests in transactions

Other than as disclosed in this circular, none of the directors of IGL are a party to any transactions which are or were unusual in their nature or conditions or significant to the business of IGL and its subsidiaries other than for normal banking relationships on an arms length basis, which were effected during the current or immediately preceding financial year or during an earlier financial period and which remain outstanding or unperformed other than the following:

- *Private Banking* – several of the directors of IGL and related parties are clients of IGL's private banking operation and are provided in the ordinary course with credit cards, loans and other banking services on an arms length basis;
- *Taaibos Square (Pty) Limited* – IGL has an outstanding loan of R26 million to Taaibos Square (Pty) Limited in which Hugh Herman has a 10,5 per cent. interest. The loan was provided on an arms length basis and is fully secured; and
- *Boutique Finance II Limited* – the transaction relates to the purchase of shares in Insinger SA by senior management through a limited company. Investec Bank (UK) Limited provided a loan of R60 million to Boutique Finance II Limited secured on the investment in Insinger SA. The terms of the loan and security arrangements require 200 per cent. cover at all times. Ian Kantor has guaranteed 34 per cent. of the loan.

14.3 Reconstitution of the board of directors of IGL

Prior to the IGL unbundling and the implementation of the DLC Structure, the IGL Board will be reconstituted. It is intended that the Boards of IGL and Investec PLC, which will comprise the same persons, will comprise four executive directors and 10 non-executive directors. The details of the individuals who will comprise the reconstituted board of directors and details of the service agreements, which such individuals intend to enter into with IGL and Investec PLC, are set out below:

Stephen Koseff

Mr Koseff will be employed by Investec PLC and IGL under an indefinite contract of employment terminable by either party giving six months written notice to the other. He will receive a basic salary of £280,000 per annum. He is also eligible for an annual bonus, the amount of which will be determined at the discretion of an IGL board committee on remuneration, which consists entirely of non-executive directors ("the remuneration committee"). Mr Koseff may elect to sacrifice a portion of his annual salary to receive company benefits such as travel allowance, provident fund, medical aid, group life insurance, pension and company care. The full cost of these benefits would be deducted from Mr Koseff's salary. Mr Koseff's contract of employment contains no provisions for compensation payable upon early termination.

Bernard Kantor

Mr Kantor will be employed by Investec PLC and IGL under an indefinite contract of employment terminable by either party giving six months written notice to the other. He will receive a basic salary of £280,000 per annum. He is also eligible for an annual bonus, the amount of which will be determined at the discretion of the remuneration committee. Mr Kantor may elect to sacrifice a portion of his annual salary to receive company benefits such as travel allowance, provident fund, medical aid, group life insurance, pension and company care. The full cost of these benefits would be deducted from Mr Kantor's salary. Mr Kantor's contract of employment contains no provisions for compensation payable upon early termination.

In order to ensure compliance with the South African Ministry of Finance conditions to the DLC Structure as set out in paragraph 2.9.1 of Annexure 1 to this circular, it is intended that a further two executive directors will be appointed to the Investec PLC and IGL Boards prior to the IGL and Inhold general meetings.

The non-executive directors of IGL and Investec PLC receive the remuneration and benefits described below:

Hugh Herman

Mr Herman will serve as the non-executive chairman of Investec PLC and IGL. Mr Herman will be paid an annual fee of R2,250,000. He is also eligible for an annual bonus, the amount of which will be determined at the discretion of the remuneration committee.

John Abell

Mr Abell will receive an annual fee of £30,000 for his appointment as a non-executive director to the Boards of Investec PLC and IGL. He will receive an additional fee of £5,000 for each additional committee of the Boards on which he accepts a position.

Sam Abrahams

Mr Abrahams will receive an annual fee of £30,000 for his appointment as a non-executive director to the Boards of Investec PLC and IGL. He will receive an additional fee of £5,000 for each additional committee of the Boards on which he accepts a position. Mr Abrahams also receives an annual fixed fee of R575,000 for consulting services that he provides to Investec.

George Alford

Mr Alford will receive an annual fee of £30,000 for his appointment as a non-executive director to the Boards of Investec PLC and IGL. He will receive an additional fee of £5,000 for each additional committee of the Boards on which he accepts a position.

Lord Grabiner

Lord Grabiner will receive an annual fee of £30,000 for his appointment as a non-executive director to the Boards of Investec PLC and IGL. He will receive an additional fee of £5,000 for each additional committee of the Boards on which he accepts a position.

Donn Jowell

Mr Jowell will receive an annual fee of £30,000 for his appointment as a non-executive director to the Boards of Investec PLC and IGL. He will receive an additional fee of £5,000 for each additional committee of the Boards on which he accepts a position. Mr Jowell also receives an annual fixed fee of R1,600,000 for consulting services that he provides to Investec.

Ian Kantor

Mr Kantor will received an annual fee of £30,000 for his appointment as a non-executive director to the Boards of Investec PLC and IGL. He will receive an additional fee of £5,000 for each additional committee of the Boards on which he accepts a position.

Sir Chips Keswick

Sir Chips Keswick will receive an annual fee of £30,000 for his appointment as a non-executive director to the Boards of Investec PLC and IGL. He will receive an additional fee of £5,000 for each additional committee of the Boards on which he accepts a position.

Peter Malungani

Peter Malungani will receive an annual fee of £30,000 for his appointment as a non-executive director to the Boards of Investec PLC and IGL. He will receive an additional fee of £5,000 for each additional committee of the Boards on which he accepts a position.

Peter Thomas

Mr Thomas will receive an annual fee of £30,000 for his appointment as a non-executive director to the Boards of Investec PLC and IGL. He will receive an additional fee of £5,000 for each additional committee of the Boards on which he accepts a position. Mr Thomas also receives an annual fixed fee of R550 000, for consulting services that he provides to Investec.

Save as set out in this paragraph, there are no existing or proposed service agreements between any director and, IGL, Investec PLC or any of their subsidiaries.

The remuneration packages for each of the directors have been determined by the remuneration committee having taken advice on market competitive remuneration levels. Salaries will be subject to review at the end of each year.

The total aggregate of the remuneration paid and benefits in kind granted to the directors of IGL by any member of the Investec group for the financial year ended 31 March 2002 under any description whatsoever was £1.1 million (this figure excludes any performance related remuneration for such period).

15. LITIGATION STATEMENT

Neither Inhold nor IGL is or has been involved in any legal or arbitration proceedings, nor, so far as the directors of Inhold and the directors of IGL are aware, are there any legal or arbitration proceedings pending or threatened involving Inhold or IGL, which may have or have had in the previous 12 months a significant effect on Inhold's financial position or IGL's financial position.

16. EXPERTS' CONSENTS

The merchant bank, lead sponsor, co-sponsor, South African law advisers, English law advisers, reporting accountants and auditors have given and have not withdrawn their consents to the inclusion of their names in this circular in the form and context in which they appear, prior to the date of issue of this circular.

17. OPINION AND RECOMMENDATION

The board of directors of Inhold and the board of directors of IGL as currently constituted, has considered the terms and conditions of the transactions and are of the opinion that they are fair and reasonable to Inhold members and IGL members, as the case may be, and recommend that Inhold members and IGL member vote in favour of the relevant resolutions necessary to implement the transactions. All the directors of Inhold and IGL who hold shares in Inhold and/or IGL intend to vote in favour of the resolutions for the implementation of the transactions.

18. NOTICES OF GENERAL MEETINGS

A general meeting of Inhold members will be held at 09:00 on Friday, 12 July 2002 for the purpose of considering and, if deemed fit, passing, with or without modification, the resolutions necessary for, *inter alia*, the Inhold unbundling, the Inhold delisting and the Inhold winding-up.

A form of proxy (blue) for use by certificated Inhold members and dematerialised "own name" Inhold members who are unable to attend the Inhold general meeting, but who wish to be represented thereat, is attached to and forms part of this circular.

Dematerialised Inhold members must inform their CSDP or broker of their intention to attend the Inhold general meeting in order to be issued with the necessary authorisation to attend and vote at the Inhold general meeting. Alternatively dematerialised Inhold members who are unable to attend the Inhold general meeting, but who wish to be represented thereat, must provide their CSDP or broker with their voting instructions.

A general meeting of IGL members will be held at 09:30, or as soon thereafter as the Inhold general meeting is concluded, on Friday, 12 July 2002 for the purpose of considering and, if deemed fit, passing, with or without modification, the resolutions necessary for, *inter alia*, the IGL internal restructure, the IGL capital restructure, the IGL unbundling and the implementation of the DLC Structure.

A form of proxy (yellow) for use by certificated IGL members and dematerialised "own name" IGL members who are unable to attend the IGL general meeting, but who wish to be represented thereat, is attached to and forms part of this circular.

Dematerialised IGL members must inform their CSDP or broker of their intention to attend the IGL general meeting in order to be issued with the necessary authorisation to attend and vote at the IGL general meeting. Alternatively, dematerialised IGL members who are unable to attend the IGL general meeting, but who wish to be represented thereat, must provide their CSDP or broker with their voting instructions.

19. DIRECTORS' RESPONSIBILITY STATEMENT

The directors of Inhold and IGL, whose names are given on page 14 of this circular, collectively and individually, accept full responsibility for the accuracy of the information given in this circular in respect of Inhold or IGL, as the case may be, and certify that, to the best of their knowledge and belief, there are no other facts the omission of which would make any statement false or misleading and that they have made all reasonable enquiries to ascertain such facts.

20. DOCUMENTS AVAILABLE FOR INSPECTION

The following documents, or copies thereof, will be available for inspection by Inhold and IGL members during normal business hours (Saturday, Sundays and public holidays excluded) at the registered office of Inhold and IGL from Thursday, 20 June 2002 to Friday, 12 July 2002:

- a signed copy of this circular;
- the audited financial annual financial statements of Inhold and IGL for the three financial years ended 31 March 2001;
- the published annual results of Inhold and IGL for the financial year ended 31 March 2002;
- the current memorandum and articles of association of both Inhold and IGL;
- the agreements necessary to give effect to the IGL reorganisation in draft form;
- the IGL internal restructure agreements in draft form;
- the IGL Memorandum and Articles to be adopted in terms of paragraph 4.4 above in draft form;
- the DLC Agreements in draft form;
- the Investec PLC Memorandum and Articles in draft form;
- the IGL employee ownership schemes, the Investec PLC employee share plans and the Investec PLC employee trusts in draft form;
- the experts' consents referred to in paragraph 16 above; and
- an undertaking given by Investec PLC and IGL to the FSA on 11 June 2002 and 22 May 2002, respectively, pursuant to which the Boards of Investec PLC and IGL confirm that: (i) they have considered and accepted the FSA's legal and supervisory conditions summarised in paragraph 2.9.3. of Annexure I to this circular; (ii) they understand that the FSA has entered into a Memorandum of Understanding with SARB; (iii) they understand that the FSA's legal and supervisory conditions summarised in paragraph 2.9 of Annexure I to this circular will be met on a continuing basis and the FSA will be notified immediately if, for whatever reason, one or more of the conditions ceases to be met;

By order of the board

INVESTEC GROUP LIMITED

Selwyn Noik
Company Secretary

Sandton
20 June 2002

By order of the board

INVESTEC HOLDINGS LIMITED

Selwyn Noik
Company Secretary

Sandton
20 June 2002

DETAILS OF THE DLC STRUCTURE

I. INTRODUCTION

This Annexure I assumes that the IGL reorganisation, the IGL internal restructure, the IGL capital restructure, the IGL unbundling and the DLC Structure have come into effect.

On the IGL unbundling, the DLC Agreements which implement the DLC Structure will come into effect. This Annexure I summarises the key features of the DLC Structure and the DLC Agreements. Further information on the DLC Agreements is set out in paragraph 16 of this Annexure I. See documents available for inspection in paragraph 20 of this circular for information on the availability of the DLC Agreements for inspection.

The following is a simplified illustration of the DLC Structure:

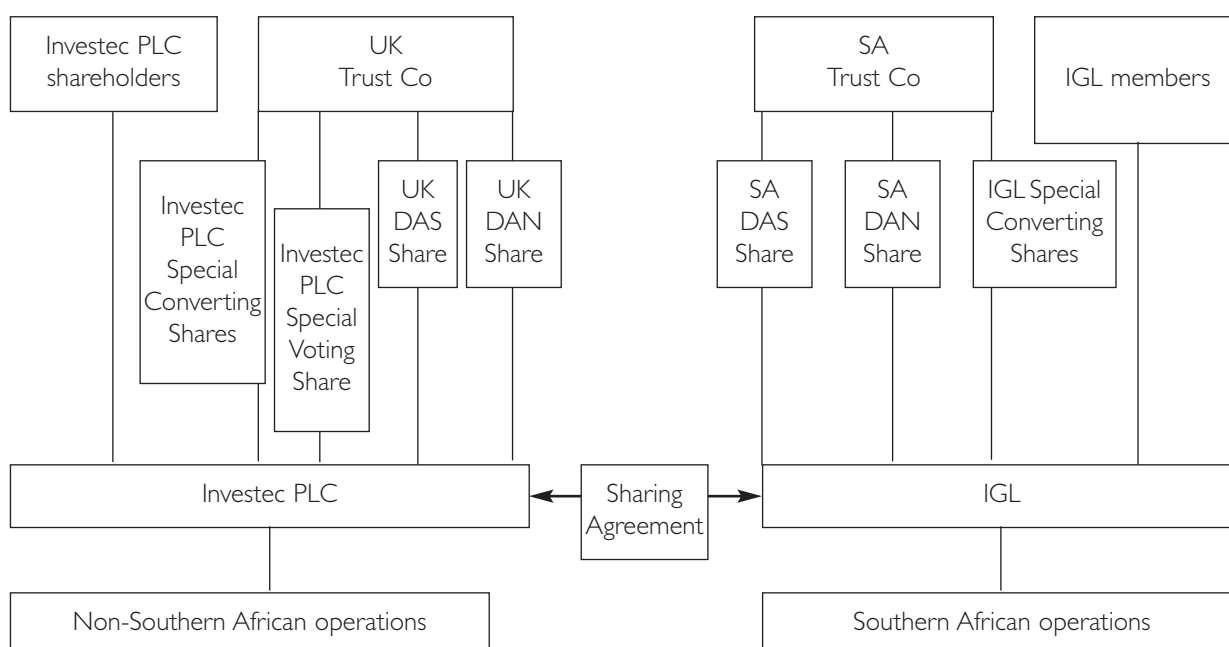

Note: On the Investec PLC side, the Investec PLC Special Voting Share is used to reflect the votes cast by IGL members. On the IGL side, the IGL Special Converting Shares are used to reflect the votes cast by Investec PLC shareholders and therefore there is no IGL Special Voting Share.

2. KEY FEATURES OF THE DLC STRUCTURE

2.1 Separate entities and listings

IGL and Investec PLC will have separate corporate identities and separate stock exchange listings.

IGL will continue to have a primary listing on the JSE and Investec PLC is seeking a primary listing on the Official List and a secondary listing on the JSE.

Following admission Investec PLC will be eligible for inclusion in the FTSE indices. In South Africa, on the JSE, Investec PLC and IGL will be considered together, as a single enterprise, for the purposes of index inclusion.

2.2 Holdings of IGL and Investec PLC ordinary shares

IGL members will continue to hold their shares in IGL. However, immediately prior to the IGL unbundling, the IGL capital restructure will be effected in respect of IGL ordinary shares such that each IGL member received 37 IGL ordinary shares for every 100 IGL ordinary shares held prior to the IGL capital restructure. On the IGL unbundling, each IGL member will receive 63 Investec PLC ordinary shares for every 37 IGL ordinary shares held following the IGL capital restructure. The combined effect of the IGL capital restructure and the IGL

unbundling is that each relevant IGL member will continue to hold the same number of shares, but a shareholder with an initial holding of 100 IGL ordinary shares now holds 63 Investec PLC ordinary shares and 37 IGL ordinary shares.

Following implementation of the DLC Structure, any ordinary share held in either Investec PLC or IGL gives the holder an equivalent effective economic interest in Investec.

2.3 Unified boards and management

Investec will operate as a single corporate group. As IGL and Investec PLC will be separate corporate entities, they will each continue to have a board of directors, but the Boards of Investec PLC and IGL will be comprised of the same persons. The Boards of Investec PLC and IGL will, in addition to their duties to the company concerned, have regard to the interests of both the IGL members and Investec PLC shareholders as if the two companies were a single economic enterprise.

Details of the proposed membership of the Boards of Investec PLC and IGL following the implementation of the DLC Structure are set out in paragraph 14.3 of this circular.

Resolutions relating to the appointment, removal and re-election of directors will be considered as Joint Electorate Actions (see paragraphs 2.5 and 8 below). Details of the proposed membership of the Boards of Investec PLC and IGL following implementation of the DLC Structure are set out in paragraph 14.3 of this circular.

2.4 Equivalent economic interests

Both IGL members and Investec PLC shareholders will have economic and voting interests in Investec. The economic and voting interests represented by an ordinary share in one company relative to the economic and voting interests of an ordinary share in the other company will be determined by reference to a ratio known as the "Equalisation Ratio".

Following the IGL unbundling, the economic and voting interests attached to each IGL ordinary share and each Investec PLC ordinary share are the same, on the basis that the initial Equalisation Ratio is 1:1.

This means, for example, that the amount of any cash dividend paid in respect of each IGL ordinary share will normally be matched by an equivalent cash dividend in respect of each Investec PLC ordinary share, and *vice versa*. To enable such matching dividends to be paid, IGL and Investec PLC have each issued Dividend Access Shares to SA Trust Co and UK Trust Co respectively.

For further information in relation to equalisation, and the payment of dividends, see paragraphs 6 and 7 below.

2.5 Voting arrangements

Under the terms of the DLC Agreements, the IGL Articles and the Investec PLC Articles, special voting arrangements are in place so that the shareholders of both companies effectively vote together as a single decision-making body on matters affecting the shareholders of each company in similar ways ("Joint Electorate Actions"). For so long as the Equalisation Ratio remains 1:1, each IGL ordinary share will effectively have the same voting rights as each Investec PLC ordinary share on Joint Electorate Actions.

In the case of certain actions in relation to which the two bodies of shareholders may have divergent interests ("Class Rights Actions"), the company wishing to carry out the Class Rights Action would require the prior approval of both the shareholders in the other company voting separately and the approval of its own shareholders voting separately.

These voting arrangements are secured through the constitutional documents of the two companies, the Sharing Agreement, the Voting Agreement and the rights attaching to, in the case of IGL, specially created special converting shares ("IGL Special Converting Shares") and, in the case of Investec PLC, a specially created special voting share ("Investec PLC Special Voting Share") issued by IGL and Investec PLC, respectively, and held, in each case, by the relevant Trust Company.

For more information about the voting arrangements see paragraph 8 below.

2.6 Restrictions on takeovers of one company only

The IGL Articles and the Investec PLC Articles ensure that a person cannot gain control of one company without having made an equivalent offer to the shareholders of both companies on equivalent terms.

It is noted that the foregoing will be enforced by the IGL Board and the Investec PLC Board through the IGL Articles and Investec PLC Articles. The Securities Regulation Code on Takeovers and Mergers and the Rules of the SRP will only apply when the threshold (presently 35%) provided for in the SRP Code is reached in which event it will only apply to IGL.

For further details in relation to these provisions, see paragraph 9 below.

2.7 Termination

On termination of the DLC Structure (for whatever reason) it will be necessary to ensure the structure is unwound so that, immediately following termination, the economic interest of a holder of one IGL ordinary share relative to the economic interest of a holder of one Investec PLC ordinary share is in proportion to the Equalisation Ratio at the moment of termination. To ensure that this is the case, each of IGL and Investec PLC have issued to SA Trust Co and UK Trust Co respectively, a new class of Special Converting Shares ("Special Converting Shares"). Prior to termination, the Special Converting Shares will have only limited rights and will be held on trust for the shareholders in the other company. Following termination, the Special Converting Shares will carry the same rights and be converted into ordinary shares in the relevant company and the shareholders in the other company will, with certain exceptions, be entitled to have the converted shares transferred to them. For more information on termination, the Special Converting Shares and the transfer thereof, see paragraph 12 below.

2.8 The Trust Companies

As set out above, SA Trust Co holds the IGL Special Converting Shares, the SA DAN Share and the SA DAS Share and UK Trust Co holds the Investec PLC Special Voting Share, the Investec PLC Special Converting Shares, the UK DAN Share and the UK DAS Share.

SA Trust Co holds the SA DAN Share and the SA DAS Share on trust for the benefit of the non-South African resident Investec PLC shareholders and the South African resident Investec PLC shareholders respectively. The IGL Special Converting Shares will, with the exception of the voting rights, also be held on trust for the Investec PLC shareholders. Prior to the Conversion Date, the voting rights attaching to the IGL Special Converting Shares are held legally and beneficially by SA Trust Co.

UK Trust Co holds the UK DAN Share and the UK DAS Share on trust for the benefit of the non-South African resident IGL members and the South African resident IGL members respectively. The Investec PLC Special Converting Shares are held on trust for the IGL members. The Investec PLC Special Voting Share is held legally and beneficially by UK Trust Co.

The rights and obligations of the Trust Companies in relation to these shares will be set out in the DLC Agreements (see paragraphs 3 and 16 below), the IGL Articles and Investec PLC Articles.

SA Trust Co will be incorporated in South Africa and UK Trust Co is incorporated in England and Wales. The shares in the Trust Companies are held (legally and beneficially) by Trust Corporation.

Trust Corporation has responsibility for the administration of the Trust Companies pursuant to the Corporate Services Agreement (which is summarised in paragraph 17 below).

2.9 Regulatory conditions as a result of the DLC Structure

Set out below is a summary of the conditions imposed by the South African Ministry of Finance and FSA as a result of the DLC Structure:

2.9.1 South African Ministry of Finance conditions to the DLC Structure

The South African Ministry of Finance has granted approval for the DLC Structure subject to the following prudential regulation conditions:

- The Office for Banks must be the lead regulatory/primary consolidated supervisor of the combined DLC Structure; and
- No funds may flow from IGL (including its subsidiaries) for the purpose of satisfying any claims arising from the winding-up of Investec PLC (including its subsidiaries) unless the prior written approval of EXCON and the Office for Banks has been obtained.

The South African Ministry of Finance has also required, as part of its approval, the following national identity conditions:

- IGL must remain a South African incorporated company with its primary listing on the JSE;

- IGL must remain a holding company of and manage and control Investec's Southern African operations, including but not limited to, *inter alia*, Investec Bank Limited, Securities Investment Bank Limited, Investec Bank (Mauritius) Limited and Investec Bank (Botswana) Limited;
- All acquisitions in the South African Development Community Region are subject to the prior written approval of both the Office for Banks and EXCON and must be structured under IGL;
- The headquarters of IGL as well as the key Group functions (for example, compliance, risk management and internal audit) of the DLC Structure (to the extent that they refer to the activities of Investec) must be in South Africa, although the headquarters of Investec PLC may be in the United Kingdom. The centre of administrative and practical management of the DLC Structure must be in South Africa, and the corporate head office activities presently carried out in South Africa must continue there;
- The headquarters of the combined DLC Structure must be publicly acknowledged as being in South Africa in all relevant significant public announcements and in all public documents;
- The Chief Executive Officer, the Chief Financial Officer of IGL and at least two of the Executive Directors of Investec PLC shall have their ordinary residence, principal offices and key supporting functions in South Africa;
- The majority of all regularly scheduled Board meetings and executive committee meetings of IGL and Executive Committee meetings of the combined DLC Structure in a calendar year must be in South Africa; and
- IGL and Investec PLC together with their subsidiaries and associates shall be "connected persons" for purposes of the South African Income Tax Act, 1953 (Act No. 34 of 1953 – as amended) and other South African income tax purposes.

The South African Ministry of Finance has imposed the following listing and shareholder arrangements conditions:

- Investec PLC must have a secondary listing on the JSE;
- Appropriate alternative Matching Actions shall be taken in respect of South African resident shareholders in Investec PLC (including its subsidiaries) who are impeded from following their rights, owing to exchange control regulations or otherwise; and
- Any dispute between any of the relevant parties arising from the terms or provisions of either the DLC Structure Sharing Agreement and/or the South African Dividend Access Trusts and/or the United Kingdom Dividend Access Trusts shall be resolved in accordance with South African law and be subject to the exclusive jurisdiction of the appropriate South African Courts.

The South African Ministry of Finance has imposed the following general conditions:

- The winding-up of either Investec PLC (including its subsidiaries) or IGL (including its subsidiaries) shall not automatically have an effect on the other relevant institution(s) in question or have an impact on the interests of the depositors, customers or creditors of such other institution(s);
- None of the South African Ministry of Finance conditions, nor any of the provisions of the Sharing Agreement and/or the United Kingdom Dividend Access Trust and/or the South African Dividend Access Trust may be amended or deviated from without the prior written approval of EXCON or the Office for Banks; and
- The conditions are subject to the provisions of the Memorandum of Understanding entered into between the FSA and the Office for Banks.

The South African Ministry of Finance has imposed certain Exchange Control Conditions including:

- Neither IGL (including its subsidiaries) nor Investec PLC (including its subsidiaries) may issue any blanket cross-guarantees between themselves; nor may IGL (including its subsidiaries) issue any other guarantees in favour of Investec PLC (including its subsidiaries) without the prior written approval of EXCON;
- Investec PLC (including its subsidiaries) may not buy or sell any shares in IGL (including its subsidiaries) without the prior written approval of EXCON and the Office for Banks;
- The Sharing Agreement shall determine that the dividend payout ratio (or dividend cover ratio) of IGL and Investec PLC shall at the times be identical. Furthermore, the prior written approval of EXCON and the Office for Banks must be obtained before IGL (including its subsidiaries) can finance a payment or any part of the payment of a dividend to members of Investec PLC (including its subsidiaries);

- Investec shall maintain an acceptable dividend payout schedule of any proposed dividend payouts in terms of the Sharing Agreement and this must be submitted to EXCON prior to the declaration of dividends;
- IGL (including its subsidiaries) shall not provide any assets, finance or capital to Investec PLC (including its subsidiaries), or to non-South African resident shareholders or to any other non-South African resident persons without the prior written approval of EXCON and the Office for Banks;
- Investec PLC shall maintain a branch register in South Africa, as envisaged and provided for in the Companies Act, 1973 (Act 61 of 1973), as amended, with regard to all members of Investec PLC who are resident in South Africa. All rights, titles and interests attached to Investec PLC's shares held by South African residents and/or entered into the branch register shall be subject to the relevant exchange control regulations; and
- Investec PLC (including its subsidiaries) may not raise any capital on the JSE without the prior written approval of EXCON.

2.9.2 FSA conditions

FSA has imposed the following conditions upon Investec as a result of the DLC Structure:

- Investec Bank (UK) Limited and any other authorised United Kingdom incorporated entity must meet United Kingdom FSA's threshold conditions and all relevant rules on a continuing basis;
- Each United Kingdom authorised firm must be registered in the United Kingdom and have its principal place of business and head office in the United Kingdom;
- Investec must remain organised so that FSA's prudential supervision of Investec PLC and its subsidiaries is not compromised by any arrangement with IGL;
- Investec PLC must meet United Kingdom corporate governance and listing requirements;
- Investec must remain structured in such a way that the DLC Structure does not make it more likely that an insolvency on one side would lead to an insolvency of, or a need to wind up, the other side;
- Investec must be subject to quantitative and qualitative consolidated supervision equivalent to the standards set out in the Basel Core Principles on consolidated supervision;
- A lead regulator for Investec will be determined in accordance with the provisions of an existing Memorandum of Understanding between the FSA and the South African Office for Banks;
- FSA approval is required for any guarantees between the two parts of the DLC Structure; and
- Investec Bank (UK) Limited must be ring fenced from the IGL group.

3. CONTRACTUAL RELATIONSHIPS FOLLOWING IMPLEMENTATION OF THE DLC STRUCTURE

The DLC Agreements, being:

- (a) the Sharing Agreement;
- (b) the Voting Agreement;
- (c) the IGL Special Converting Shares Trust Deed;
- (d) the Investec PLC Special Converting Shares Trust Deed;
- (e) the UK DAS Share Trust Deed;
- (f) the UK DAN Share Trust Deed;
- (g) the SA DAS Share Trust Deed; and
- (h) the SA DAN Share Trust Deed,

(which are summarised in paragraphs 16.2 to 16.9 below) together with the IGL Articles (which are summarised in Annexure XIV to this circular) and Investec PLC Memorandum and Articles, came into effect on the IGL unbundling and govern the ongoing relationship between IGL and Investec PLC and establish the relationship between IGL, Investec PLC and the Trust Companies.

4. DLC STRUCTURE PRINCIPLES

The Sharing Agreement provides that the relationship between IGL and Investec PLC will be underpinned by the DLC Structure Principles which are as follows:

- (a) the IGL group and the Investec PLC group must operate as if they were a single corporate group, through boards of directors which comprise the same individuals;
- (b) the directors of IGL and the directors of Investec PLC will, in addition to their duties to the company concerned, have regard to the interests of IGL members and Investec PLC shareholders as if the two companies were a single unified economic enterprise and for that purpose the directors of each company will take into account, in the exercise of their powers, the interests of the members of the other; and
- (c) the DLC Equalisation Principles (see paragraph 6 below) must be observed.

IGL and Investec PLC agree, subject to Applicable Regulation including the conditions relating to the DLC Structure set out in paragraph 2.9 of this Annexure I, to pursue the DLC Structure Principles.

5. MANAGEMENT

5.1 Board of Directors

Each of IGL and Investec PLC has a board of directors and each board comprises the same individuals.

(a) **Board meetings**

The Boards of Investec PLC and IGL will hold regularly scheduled meetings each year. Scheduled meetings, which are likely to be held once a quarter, will comprise meetings of both the Investec PLC Board and the IGL Board. Other exclusive meetings of either the IGL Board or the Investec PLC Board to discuss matters relating specifically to the business of either IGL or Investec PLC (as the case may be) will be held from time to time as required so that in practice it is expected that each of the Boards of Investec PLC and IGL will meet once every two months. It is intended that half of the meetings which comprise meetings of both the Investec PLC Board and the IGL Board will be held in South Africa and half in the United Kingdom, the majority of Investec PLC only meetings will be held in the United Kingdom and the majority of IGL only meetings will be held in South Africa.

(b) **Board responsibility**

The Boards of Investec PLC and IGL will respectively pursue the DLC Structure Principles (see paragraph 4 above).

Meetings which comprise meetings of both the Investec PLC Board and the IGL Board will consider the overall direction of the businesses of both companies including major policy and strategic decisions of both companies. For example, the following types of matters which would affect Investec will be considered at such meetings:

- setting overall strategy and direction of the businesses;
- taking decisions on integrating or separating major businesses on a global scale;
- approving acquisitions and disposals and debt financing over a certain threshold;
- declaring dividends;
- approving the Investec accounts and appointing and removing group auditors; and
- taking policy decisions affecting employees worldwide.

Meetings which comprise meetings of either the Investec PLC Board only or the IGL Board only will be responsible for the following types of matters:

- approving acquisitions and disposals and debt financing under a certain threshold;
- approving material operational proposals which affect directly the activities conducted in Southern Africa and internationally, by IGL and Investec PLC respectively; and
- taking decisions regarding the capitalisation of subsidiaries of the relevant company.

(c) **Board members**

The composition of the Boards of Investec PLC and IGL following implementation of the DLC Structure is set out in paragraph 14.3 of this circular.

5.2 Management forums

Under the DLC Structure, a combined and two regional management forums have been established and comprise the existing global and regional management of the Southern African and non-Southern African operations.

6. EQUALISATION OF VOTING AND ECONOMIC RIGHTS

6.1 DLC Equalisation Principles

The principles to be observed in relation to the rights of the IGL ordinary shares and the Investec PLC ordinary shares are set out below:

- (a) The Equalisation Ratio will define the economic benefits of one IGL ordinary share relative to one Investec PLC ordinary share (and *vice versa*) and the relative voting rights of one IGL ordinary share and one Investec PLC ordinary share on Joint Electorate Actions so that, where the Equalisation Ratio is 1:1, a holder of one IGL ordinary share and a holder of one Investec PLC ordinary share will, as far as practicable:
 - (i) receive equivalent economic benefit (as to capital and dividends); and
 - (ii) enjoy equivalent rights as to voting in relation to Joint Electorate Actions,and, where the Equalisation Ratio is not 1:1 such economic benefits and such voting rights as between an IGL ordinary share and an Investec PLC ordinary share will be in proportion to the prevailing Equalisation Ratio.

For the purposes of the DLC Equalisation Principles, the economic benefit of an ordinary share of IGL or Investec PLC shall include any rights or benefits accruing to the shareholders by way of payments made or other Actions taken in respect of the Dividend Access Shares.
- (b) If Investec PLC or IGL undertakes an Action which, having regard for the prevailing Equalisation Ratio, would have a disproportionate economic effect on the holders of ordinary shares in one company relative to its effect on the holders of ordinary shares in the other company, then, subject to paragraphs 6.2 and 6.3 below, an appropriate adjustment to the Equalisation Ratio will be made unless:
 - (i) a Matching Action has been or is to be undertaken; or
 - (ii) such Action has received approval as a Class Rights Action.
- (c) The Investec PLC Equivalent Number of Investec PLC Special Converting Shares will at all times be in issue and the IGL Equivalent Number of IGL Special Converting Shares will at all times be in issue.

6.2 Actions which do not have a disproportionate economic effect

The following Actions will not be considered to have a disproportionate economic effect on the shareholders in one company relative to its effect on the shareholders in the other company:

- (a) any allotment and issue of shares or the granting of rights over shares by either IGL or Investec PLC at a price not less than the prevailing market value on the date of grant, pursuant to any employee share scheme;
- (b) any allotment and issue of shares in either IGL or Investec PLC which is not an issue on a pre-emptive basis;
- (c) any buy-back, repurchase or redemption of any ordinary shares of either company (including a share cancellation in connection with a reduction of capital):
 - (i) on market in compliance with the rules of the relevant stock exchange and listing rules; or
 - (ii) at or below market value; or
 - (iii) pursuant to a general offer to shareholders in both IGL and Investec PLC which (applying the Equalisation Ratio) is made on equivalent terms; and
- (d) any allotment and issue of shares in lieu of the payment of the whole or any part of a cash dividend where (on a per ordinary share basis) the quantum of the discount offered to the shareholders in respect of the subscription price for further ordinary shares in the issuing company is less than the greater of (x) 5 per cent. of the market value of an ordinary share of the issuing company at the date of declaration of the relevant dividend and (y) the tax that would be saved by the issuing company by effecting such issue rather than paying a cash dividend.

6.3 Unadjusted Actions

In addition to the above, there is no requirement for an adjustment to the Equalisation Ratio, a Matching Action or approval as a Class Rights Action where an Action (an "Unadjusted Action") is taken in circumstances where the Boards of Investec PLC and IGL consider that the effect of such Action upon an IGL member relative to its effect on an Investec PLC shareholder is not material. For this purpose, an effect is taken to be "not material" if:

- (a) the costs to IGL and Investec PLC of taking a Matching Action or seeking approval as a Class Rights Action would be, in the opinion of the Boards of Investec PLC and IGL, disproportionate to the economic benefit conferred by such Action upon the IGL members or Investec PLC shareholders (as the case may be) for whose benefit a Matching Action would otherwise (in the absence of an adjustment to the Equalisation Ratio or approval as a Class Rights Action) be required; and
- (b) the adjustment that would be required to be made to the Equalisation Ratio would result in an adjustment to the relevant element of the Equalisation Ratio of less than 0.5 per cent.

However, in considering the application of the DLC Equalisation Principles to any subsequent Actions, the Boards of Investec PLC and IGL will take into account the effect of all prior Unadjusted Actions in deciding whether a Matching Action, an adjustment to the Equalisation Ratio or approval as a Class Rights Action is appropriate.

6.4 Tax, exchange rates and market fluctuations

In relation to any Action, when calculating any economic effect on IGL members or Investec PLC shareholders:

- (a) any tax payable by or on behalf of, or tax benefit arising to, such shareholders will be disregarded; and
- (b) in relation to any cash dividend, the amount of such dividend will be calculated before the deduction of any withholding taxes and no account will be taken of any obligation on the company making such distribution to pay any tax in relation to such distributions (such tax being payable in addition to the dividend).

The Boards of Investec PLC and IGL will not be required to take into account any fluctuations in exchange rates or in the market value of any securities or any other changes in circumstances arising after the date on which they make a determination as to the form and value of any Matching Action or the calculation of any adjustment to the Equalisation Ratio.

6.5 Timing of Action and Matching Action

A Matching Action will be implemented as soon as practicable after or, if possible, simultaneously with the Action giving rise thereto.

6.6 Applicable Regulation

Investec PLC and IGL must not take any Action which would cause any Investec entity to be in breach of any Applicable Regulation.

6.7 Suspension of rights

There will be no need to make any adjustment to the Equalisation Ratio or to do or omit to do any other thing as a result of the dividend, voting or other rights of any shareholder being suspended or curtailed pursuant to any provision of the IGL Articles or the Investec PLC Articles.

7. CASH DIVIDENDS

7.1 Currency

IGL will continue to declare and pay its dividends and other distributions in Rand. Investec PLC will declare and pay its dividends and other distributions in pounds sterling. If IGL is to pay a dividend to the Investec PLC shareholders via its Dividend Access Shares, the Investec PLC shareholders will be paid such dividend in pounds sterling (and *vice versa* if Investec PLC is to make a payment on its Dividend Access Shares).

7.2 Matching dividends

If it is proposed that the shareholders of one company should receive a cash dividend, then (subject to paragraph 7.3) the shareholders of the other company must receive, as nearly as practicable at the same time, a matching cash dividend (a "Matching Dividend") of an equivalent cash amount per ordinary share having regard

to the then prevailing Equalisation Ratio and the "Applicable Exchange Rate". The Applicable Exchange Rate used in applying the Equalisation Ratio will be the average of the Rand/pounds sterling buying and selling spot rates quoted by Investec Bank at 11:00 am (Johannesburg time) on the date on which a dividend is declared or recommended by the later of Investec PLC and IGL to do so. The Boards of Investec PLC and IGL have the power to agree a different basis for the exchange rate.

To effect the payment of Matching Dividends, IGL and Investec PLC will make payments on either their ordinary shares or their Dividend Access Shares or both. To enable payments to be made on their respective ordinary shares and Dividend Access Shares, IGL and Investec PLC will be entitled to enter into such transactions with each other or third parties as the Boards of Investec PLC and IGL agree to be necessary or desirable and/or to arrange for payments to be made on the Equalisation Shares (if issued).

For further information in relation to Dividend Access Shares see paragraph 7.4 below and for further information on the Equalisation Shares see paragraph 7.5 below.

The payment of Matching Dividends will not restrict either company's ability to offer to its shareholders the ability to elect to subscribe for further shares of such company in lieu of the whole or any part of a cash dividend.

7.3 No matching dividend to be paid

If either company is prohibited by Applicable Regulation or is otherwise unable to declare, pay or otherwise make all or any portion of such a Matching Dividend or the directors of IGL and Investec PLC decide that it is not practicable or desirable to declare or pay a Matching Dividend, then IGL and Investec PLC will, so far as it is practicable to do so, take some other form of Matching Action and the DLC Equalisation Principles will apply.

7.4 Dividend Access Shares

To facilitate the payment of Matching Dividends, dividend access trust arrangements have been established as part of the DLC Structure.

IGL has issued two Dividend Access Shares, the SA DAS Share and the SA DAN Share to SA Trust Co. SA Trust Co holds the SA DAS Share and the SA DAN Share separately on trust for the benefit of the South African resident Investec PLC shareholders and the non-South African resident Investec PLC shareholders respectively. IGL will undertake on behalf of SA Trust Co the distribution of any dividend payments, made by IGL, to such shareholders.

Similarly, Investec PLC has issued two Dividend Access Shares, the UK DAS Share and the UK DAN Share to UK Trust Co. UK Trust Co holds the UK DAS Share and the UK DAN Share separately on trust for the benefit of the South African resident IGL members and the non-South African resident IGL members respectively. Investec PLC will undertake on behalf of UK Trust Co the distribution of any dividend payments, made by Investec PLC, to such shareholders.

The Dividend Access Shares enable therefore, each company to pay dividends to the shareholders in the other company. For example, in respect of any dividend declared or announced by the companies, a South African resident Investec PLC shareholder may receive part of his dividend entitlement via a payment made on his Investec PLC ordinary shares and the remainder via a payment on the SA DAS Share. This facility may be used by the Boards of Investec PLC and IGL to address imbalances in the distributable reserves of Investec PLC and IGL and/or to address the effect of South African exchange controls (see paragraph 2.9 above) and/or if they otherwise consider it necessary or desirable.

7.5 Equalisation Shares

The Sharing Agreement provides that a share may be allotted and issued by a member of each company's group to a member of the other company's group. Distributions may be on these Equalisation Shares if the Boards of Investec PLC and IGL consider it necessary or desirable, which may include a distribution to enable the payment of Matching Dividends. There is no current intention to issue such shares.

8. SHAREHOLDER VOTING RIGHTS

8.1 Categories of shareholder decisions

There will be four categories of matters or actions requiring shareholder decisions:

- (a) Joint Electorate Actions (described in paragraph 8.2 below);
- (b) Class Rights Actions (described in paragraph 8.3 below);

- (c) other actions: any action which is neither a Class Rights Action nor a Joint Electorate Action but which, under applicable law or regulation, or under the IGL Memorandum and Articles or the Investec PLC Memorandum and Articles, requires shareholder approval. Such actions require only the approval of the shareholders of the company proposing to take the relevant action, unless the Boards of Investec PLC and IGL decide that such action should be treated as a Joint Electorate Action or Class Rights Action; and
- (d) procedural resolutions: procedural resolutions, where considered at a shareholders' meeting at which the holder of the Investec PLC Special Voting Share and/or the holder of the IGL Special Converting Shares is entitled to vote, may be voted on by the relevant holder either in person in accordance with the directions of the chair of the meeting or by proxy given to the chair of the meeting, who will cast such votes as he thinks fit.

8.2 Joint Electorate Actions

The shareholders of IGL and of Investec PLC will vote together as a joint electorate on matters affecting them in similar ways. The special voting procedure in respect of Joint Electorate Actions is described below.

Matters which will require approval as a Joint Electorate Action are as follows:

- (a) the appointment, removal or re-election of any director of IGL or of Investec PLC, or both of them;
- (b) the receipt or adoption of the annual accounts of IGL or of Investec PLC, or both of them, or accounts prepared on a combined basis;
- (c) a change of name by IGL or Investec PLC, or both of them;
- (d) the appointment or removal of the auditors of IGL or of Investec PLC, or both of them;
- (e) any proposed acquisition, disposal or other transaction of the kinds referred to in the Listings Requirements or the UK Listing Rules which (in any case) is required under those regulations to be authorised by holders of ordinary shares in either company;
- (f) any matter considered at an annual general meeting of IGL or Investec PLC (or at a general meeting convened on the same day as an annual general meeting); and
- (g) any other matter which the Boards of Investec PLC and IGL decide (either in a particular case or generally) should be approved as a Joint Electorate Action.

Voting procedures for Joint Electorate Actions

Joint Electorate Actions must be submitted to the shareholders of both IGL and Investec PLC for approval at separate meetings but acting as a joint electorate. Parallel shareholders' meetings will be held on the same date or as close together in time as practicable.

Procedure for Joint Electorate Actions

The IGL meeting

- At the IGL members' meeting, voting will be on a poll which will (as regards the IGL Special Converting Shares) remain open for sufficient time to allow the parallel Investec PLC shareholders' meeting to be held and for the IGL Special Converting Shares votes to be ascertained and cast on the poll.
- On the poll:
 - each IGL ordinary share (other than those that are subject to voting restrictions) will have one vote; and
 - SA Trust Co, as holder of the IGL Special Converting Shares, will cast (if the Equalisation Ratio is 1:1) the same number of votes as were validly cast for and against the equivalent resolution at the parallel Investec PLC shareholders' meeting (rounded up, if necessary, to the nearest whole number).

The Investec PLC meeting

- At the corresponding Investec PLC shareholders' meeting, voting will be on a poll which will (as regards the Investec PLC Special Voting Share) remain open for sufficient time to allow the parallel IGL members' meeting to be held and for the votes attaching to the Investec PLC Special Voting Share to be ascertained and cast on the poll.
- On the poll:
 - each fully paid Investec PLC ordinary share (other than those that are subject to voting restrictions) will have one vote; and
 - UK Trust Co, as holder of the Investec PLC Special Voting Share, will cast (if the Equalisation Ratio is 1:1) the same number of votes as were validly cast for and against the equivalent resolution at the parallel IGL members' meeting, (rounded up, if necessary to the nearest whole number).

- Under the Voting Agreement, SA Trust Co will be obliged to cast these votes for and against the relevant resolution in accordance with the votes cast for and against the equivalent resolution by Investec PLC shareholders on the poll at the parallel Investec PLC shareholders' meeting.
- Through this mechanism the votes of the Investec PLC shareholders at the Investec PLC meeting will be reflected at the IGL meeting by SA Trust Co casting the votes on the IGL Special Converting Shares precisely to reflect voting at the parallel Investec PLC shareholders' meeting.
- Under the Voting Agreement, UK Trust Co will be obliged to cast these votes for and against the relevant resolution in accordance with the votes cast for and against the equivalent resolution by IGL members on the poll at the parallel IGL members' meeting.
- Through this mechanism the votes of the IGL members at the IGL meeting will be reflected at the Investec PLC meeting by UK Trust Co casting the votes on the Investec PLC Special Voting Share precisely to reflect voting at the parallel IGL members' meeting.

The results of the Joint Electorate Action will be announced after both polls have closed.

If the Equalisation Ratio at any stage ceases to be 1:1, the number of IGL Special Converting Shares allotted and issued and the number of votes attaching to the Investec PLC Special Voting Share will be adjusted to reflect the then prevailing Equalisation Ratio so as to ensure that each Investec PLC ordinary share and each IGL ordinary share carries appropriate voting rights in relation to Joint Electorate Actions.

Voting threshold for Joint Electorate Actions

A Joint Electorate Action will be taken to have been approved if it is approved by:

- (a) ordinary resolution (or a special resolution if required by Applicable Regulation or the IGL Memorandum and Articles) of the IGL members and the holder of the IGL Special Converting Shares, voting as a single class; and
- (b) ordinary resolution (or a special resolution if required by Applicable Regulation or the Investec PLC Memorandum and Articles) of the Investec PLC shareholders and the holder of the Investec PLC Special Voting Share, voting as a single class.

In this paragraph 8, ordinary resolution means any resolution of shareholders which requires a simple majority of votes cast to be in favour in order to be approved, and, special resolution means any resolution which requires a 75 per cent. majority of votes cast to be in favour in order to be approved or such other affirmative vote or quorum prescribed by Applicable Regulation, the IGL Memorandum and Articles or the Investec PLC Memorandum and Articles which is greater than or different from that required for an ordinary resolution.

8.3 Class Rights Actions

Class Rights Actions are normally those matters on which shareholders of IGL and Investec PLC may have divergent interests or which involve an amendment either to the DLC Agreements or the DLC Structure-specific provisions ("entrenched provisions") in either the IGL Articles or the Investec PLC Articles.

Matters that will require approval as a Class Rights Action are as follows:

- (a) the amendment or termination of the Sharing Agreement, the Voting Agreement, the Special Converting Shares Trust Deeds or the Dividend Access Trust Deeds other than:
 - (i) any amendment which is formal or technical in nature and which would not be materially prejudicial to the interests of the shareholders of either company or is necessary to correct any inconsistency or manifest error; or
 - (ii) any amendment to conform the terms of the Voting Agreement, the Special Converting Shares Trust Deeds or the Dividend Access Trust Deeds with the terms of the Sharing Agreement, in each case, as agreed between the Boards of Investec PLC and IGL; or
- (b) the amendment to, removal or alteration of the effect of (including the ratification of any breach of) any entrenched provision in the IGL Memorandum and Articles or the Investec PLC Memorandum and Articles (see paragraphs 13 and 14 below) other than:
 - (i) any amendment which is formal or technical in nature and would not be materially prejudicial to the interests of any shareholders of either company or is necessary to correct any inconsistency or manifest error;
 - (ii) any amendment to conform such provisions with the Sharing Agreement, in each case, as agreed between the Boards of Investec PLC and IGL; or

- (c) any Action by one company which, having regard to the prevailing Equalisation Ratio, has a disproportionate economic effect on the shareholders of one company, but in respect of which neither a Matching Action is to be taken nor an adjustment to the Equalisation Ratio made; and
- (d) any action or matter which the Boards of Investec PLC and IGL both agree (either in a particular case or generally) should be treated as a Class Rights Action.

If a particular matter falls both within the list of matters which constitute Joint Electorate Actions (see paragraph 8.2 above) and the list of matters which constitute Class Rights Actions (see above), such matter will be treated as a Class Rights Action.

Voting threshold for Class Rights Actions

Class Rights Actions of a kind described in:

- (a) paragraphs 8.3(a) and (b) above will require approval by special resolution;
- (b) paragraph 8.3(c) above will require approval by ordinary resolution unless either Applicable Regulation imposes a requirement on either company for a special resolution, in which case that company will require a special resolution; and
- (c) paragraph 8.3(d) above will require approval by ordinary resolution, unless either Applicable Regulation imposes a requirement on either company for a special resolution, in which case that company will require a special resolution, or the Boards of Investec PLC and IGL decide that it requires a special resolution.

The majority vote in favour required to approve such resolutions will be referred to as the “Required Majority” in the remainder of this paragraph 8.

Class Rights Actions will require approval by:

- (a) an ordinary resolution or a special resolution (as the case may be) of the Investec PLC shareholders and UK Trust Co (as holder of the Investec PLC Special Voting Share) voting as a single class;
- (b) an ordinary resolution or a special resolution (as the case may be) of the IGL members, voting as a single class; and
- (c) the written consent of SA Trust Co (as holder of the IGL Special Converting Shares).

Voting procedures for Class Rights Actions

The following voting arrangements apply in relation to Class Rights Actions:

Procedure for Class Rights Actions requiring approval of both companies

IGL

- The relevant resolution will be put to the IGL members voting as a single class at a general meeting of IGL. Voting will be on a poll with each IGL ordinary share (other than those that are subject to voting restrictions) having one vote per share.
- The resolution will also require a class approval of the holder of the IGL Special Converting Shares. Such approval will be given by way of written consent provided that SA Trust Co, as holder of the IGL Special Converting Shares, will not give such written consent unless the proposed action has been approved by the Required Majority of the Investec PLC shareholders at the parallel Investec PLC meeting.

Investec PLC

- The Investec PLC shareholders’ meeting will be held as close in time to the corresponding IGL members’ meeting as is practicable. Investec PLC shareholders and the holder of the Investec PLC Special Voting Share will vote as a single class at a general meeting of Investec PLC. Voting will be on a poll with each fully paid Investec PLC ordinary share (other than those that are subject to voting restrictions) having one vote per share.
- UK Trust Co, as holder of the Investec PLC Special Voting Share, will not vote unless the proposed action has not been approved by the Required Majority of the IGL members at the parallel IGL members’ meeting at the close of the poll at that meeting, in which case UK Trust Co will vote to defeat the resolution at the Investec PLC meeting (and the Investec PLC Special Voting Share will, as a result of the rights attached thereto, carry sufficient votes to effect such defeat).

- If the proposed action has not been approved by the Required Majority of the Investec PLC shareholders at the parallel Investec PLC meeting, SA Trust Co will notify IGL in writing that it does not consent to the proposed action and the resolution will be defeated.
-

8.4 The Trust Companies

The Trust Companies are obliged pursuant to the Voting Agreement, the IGL Articles and the Investec PLC Articles to exercise the votes attaching to the IGL Special Converting Shares and the Investec PLC Special Voting Share so as to give effect to the voting arrangements set out above.

8.5 Differences between Investec PLC and IGL voting arrangements

From the above it can be seen that there is not complete symmetry in the DLC Structure as regards the voting arrangements. On the Investec PLC side, the Investec PLC Special Voting Share is used to reflect the votes cast by IGL members, whereas, on the IGL side, the IGL Special Converting Shares are used to reflect the votes cast by Investec PLC shareholders. With the Investec PLC Special Voting Share, this effect is achieved by the fact that, as detailed above, the share carries a variable number of votes (referred to as the “Specified Number”). However, under South African law, it is not possible to attribute a variable number of votes to a single share. Where a South African company has different classes of share, the voting rights attributable to shares in such classes must be directly proportionate to their respective nominal values. For Joint Electorate Actions, the IGL Special Converting Shares (which have the same nominal value as IGL ordinary shares) are used to reflect the votes cast by Investec PLC shareholders given that the appropriate number will always be in issue (i.e. the Investec PLC Equivalent Number). As a result, SA Trust Co simply votes a certain number of IGL Special Converting Shares for and against a resolution to reflect the votes cast on Investec PLC ordinary shares. For Class Rights Actions, again the Investec PLC Special Voting Share creates an effective right of veto for IGL members due to the number of votes attributed to it (the number of votes always being sufficient to defeat the resolution). On the IGL side, a different approach has had to be taken and the IGL Articles require that the consent of the holder of the IGL Special Converting Shares must be obtained in order to approve a Class Rights Action. As set out in paragraph 8.3 above, such consent is only given if the Investec PLC shareholders have voted in favour of the relevant resolution.

9. TAKEOVERS REGULATION OF THE DLC STRUCTURE

9.1 Background

IGL and Investec PLC will be separate listed companies and will be subject to the takeovers laws and rules in South Africa and the United Kingdom respectively. Provisions have been included in the IGL Articles and the Investec PLC Articles which are intended to have the effect of:

- (a) recognising the substantive effect of the DLC Structure, which is that Investec should be regarded as a single corporate group;
- (b) allowing the two regulatory systems to work together harmoniously and sensibly;
- (c) respecting South African takeovers law and the United Kingdom takeovers rules respectively; and
- (d) avoiding any unintended impediment to any takeover of Investec.

9.2 Key thresholds

Under the IGL Articles and the Investec PLC Articles:

- (a) there is a limit that prevents a person (and concert parties) from exceeding a voting power threshold of 30 per cent. in relation to IGL on a stand alone basis, that is calculated as if there were no IGL Special Converting Shares and only counting IGL’s ordinary shares; and
- (b) there is a separate limit that prevents a person (and concert parties) from exceeding a voting power threshold of 30 per cent. in relation to IGL, calculated having regard to all the voting power on a joint electorate basis, i.e. calculated on IGL’s ordinary shares and on the voting power in IGL derived (through the IGL Special Converting Shares) by holding or controlling Investec PLC ordinary shares – this limit effectively treats all ordinary shares in both companies, together with the Investec PLC Special Voting Share, and the IGL Special Converting Shares as voting shares and sets a 30 per cent. limit on control of this joint electorate voting power; and

- (c) there is a limit that prevents a person (and concert parties) from exceeding a voting power threshold of 30 per cent. in relation to Investec PLC on a stand alone basis, that is calculated as if there were no Investec PLC Special Voting Share and only counting Investec PLC's ordinary shares; and
- (d) there is a separate limit that prevents a person (and concert parties) from exceeding the mandatory offer limit set out in Rule 9 of the UK City Code which imposes a voting power threshold of 30 per cent. in relation to Investec PLC, calculated having regard to all the voting power on a joint electorate basis, i.e. calculated on Investec PLC's ordinary shares and on the voting power in Investec PLC derived through the Investec PLC Special Voting Share by holding or controlling IGL ordinary shares – this limit effectively treats all ordinary shares in both companies, together with the Investec PLC Special Voting Share and the IGL Special Converting Shares, as voting shares and sets a 30 per cent. limit on control of this joint electorate voting power.

The principal requirement for exceeding a limit is for all shareholders in both companies to be treated in an equivalent manner and sanctions may be imposed for breaches of these provisions. This is explained below.

9.3 Equivalent offers on equivalent terms

The IGL Articles and the Investec PLC Articles provide, in effect, that a person may only exceed any of these limits if an equivalent offer is made to both IGL members and Investec PLC shareholders on equivalent terms. In summary, this would require:

- (a) an equivalent procedure which:
 - (i) is undertaken for both IGL ordinary shares and Investec PLC ordinary shares at or about the same time;
 - (ii) applies to both the IGL ordinary shares and the Investec PLC ordinary shares;
- (b) that each procedure complies with the IGL Articles, the Investec PLC Articles and all Applicable Regulation including the (takeover laws and rules in South Africa (as regards the offer for the IGL ordinary shares) and in the United Kingdom (as regards the offer for the Investec PLC ordinary shares); and
- (c) offer equivalent consideration, terms, information, conditions and time to consider to the IGL members and the Investec PLC shareholders, both in relation to an initial offer and any increases or extensions.

Because of the variety of takeover procedures and the different takeover regimes applying in South Africa and the United Kingdom, the concept of equivalence cannot be defined prescriptively. It is expected that a combination of the Boards of Investec PLC and IGL, the SRP and/or the UK Takeover Panel will have a role in determining and achieving equivalence in a particular case.

With equivalent treatment in terms of the opportunities afforded to each group of shareholders, each such group of shareholders (IGL and Investec PLC) will make its own decision as to whether the relevant offer is to be accepted. It is possible that one offer will become unconditional (because the minimum acceptance condition is satisfied), but that the other offer does not become unconditional (because the equivalent minimum acceptance condition is not satisfied).

9.4 Breach of limits

Under the IGL Articles and the Investec PLC Articles, if a person breaches a shareholding limit without making equivalent offers to both groups of shareholders on equivalent terms, then the IGL Articles and the Investec PLC Articles give the Boards of Investec PLC and IGL power to impose certain sanctions on the relevant shareholders. Each of the Boards of Investec PLC and IGL has power to deny dividend rights in respect of that number of IGL ordinary shares or Investec PLC ordinary shares (as the case may be) which results in the threshold being exceeded ("excess shares") and power to dispose of the excess shares. The Investec PLC Board also has power to deny voting rights in respect of the excess shares.

9.5 Sharing Agreement

Under the Sharing Agreement, IGL and Investec PLC agree to co-operate with each other in the enforcement of the restrictions in the IGL Articles and the Investec PLC Articles (respectively) described in paragraphs 9.2 and 9.4 above.

10. FINANCIAL REPORTING

IGL and Investec PLC intend to publish a single primary set of consolidated financial statements, denominated in pounds sterling and prepared in accordance with UK GAAP, and IGL will publish consolidated financial statements denominated in Rand and prepared in accordance with SA GAAP. IGL and Investec PLC will furthermore also prepare any other financial information needed to meet their respective local requirements. The financial year-end of both IGL and Investec PLC will be 31 March.

11. TERMINATION OF THE SHARING AGREEMENT

The Sharing Agreement will be terminated:

- (a) if either IGL or Investec PLC serves notice on the other at any time after either of them has become a subsidiary of the other; or where both IGL and Investec PLC have become subsidiaries of a third party; or
- (b) by the approval of the shareholders of Investec PLC and IGL as a Class Rights Action. However, such approval may only be sought if the Boards of Investec PLC and IGL have agreed terms for the termination and, so far as practicable, such terms are equitable to the IGL members and Investec PLC shareholders; or
- (c) if a Liquidation Event occurs in respect of either Investec PLC, IGL or a Significant Bank in either the IGL group or the Investec PLC group; and
 - (i) the company whose group is not directly affected by the Liquidation Event serves notice on the other company terminating the agreement; or
 - (ii) the order or resolution or appointment constituting the Liquidation Event is not revoked or rescinded within 30 days or such longer period as Applicable Regulation may allow; or
- (d) if an Insolvency Event occurs in respect of Investec PLC, IGL or a Significant Bank in either the Investec PLC group or the IGL group: and
 - (i) the company whose group is not directly affected by the Insolvency Event serves notice on the other company terminating the agreement; or
 - (ii) a proposal not to terminate the agreement has not been approved as a Class Rights Action within 90 days of the date on which the Insolvency Event occurs or such longer period as the Boards of Investec PLC and IGL may agree.

Termination will not affect any accrued rights of Investec PLC and IGL or their respective obligations to seek a listing for their Special Converting Shares (see paragraph 12.1 below).

12. EFFECT OF TERMINATION

Under the Sharing Agreement, the IGL Special Converting Shares Trust Deed, the Investec PLC Special Converting Shares Trust Deed, the IGL Articles and the Investec PLC Articles, the provisions described below apply on termination of the Sharing Agreement ("Conversion Event"). These provisions are intended to ensure that, as far as practicable, the shareholders are treated equitably in the event of insolvency of either or both companies, having regard to the Equalisation Ratio.

12.1 Special Converting Shares

Equality of treatment on termination for both sets of shareholders will be achieved through the issue of Special Converting Shares by both companies.

Investec PLC has issued the Investec PLC Equivalent Number of Investec PLC Special Converting Shares. UK Trust Co holds these shares on trust for the benefit of the IGL members. The proportion of the Investec PLC Special Converting Shares to which each IGL member is entitled corresponds to the proportion of IGL ordinary shares in issue held by such shareholder.

Similarly, IGL has issued the IGL Equivalent Number of IGL Special Converting Shares. SA Trust Co holds these shares on trust for the benefit of the Investec PLC shareholders. The proportion of the IGL Special Converting Shares to which each Investec PLC shareholder is entitled corresponds to the proportion of Investec PLC ordinary shares in issue held by such shareholder.

Under the Sharing Agreement, each of Investec PLC and IGL have agreed not to take an Action unless, as the case may be, the IGL Equivalent Number or the Investec PLC Equivalent Number of Special Converting Shares can be maintained. In the event of the occurrence of a Conversion Event, the Special Converting Shares will automatically convert into ordinary shares (see paragraph 12.2(b) below). Investec PLC will use its best endeavours to seek admission of the resulting Investec PLC ordinary shares to the Official List and to trading on

the London Stock Exchange and the JSE. IGL will similarly use its best endeavours to obtain a listing on the JSE for the IGL ordinary shares resulting from the conversion. If the shares are admitted to listing, the relevant Trust Company will distribute them to the relevant shareholders unless such shareholder resides in a Restricted Jurisdiction, in which case his shares will be sold and the proceeds (less all fees, commissions, costs, taxes and duties in respect of the sale) remitted to such shareholder.

Where converted Special Converting Shares are distributed to shareholders, the shareholders shall bear the cost of all fees, commissions, costs, taxes and duties associated with such distribution.

12.2 Rights of Special Converting Shares

(a) Prior to a Conversion Event

- (i) The IGL Special Converting Shares will have the following key rights as set out in the IGL Articles:
 - the voting rights in relation to Joint Electorate Actions and Class Rights Actions described in paragraphs 8.2 and 8.3 above; and
 - no rights to dividends.

The IGL Special Converting Shares may, prior to the occurrence of a Conversion Event, be redeemed at the discretion of the IGL Board if it is necessary or expedient in order to ensure the IGL Equivalent Number is in issue.

- (ii) The Investec PLC Special Converting Shares will have the following rights as set out in the Investec PLC Articles:
 - no voting rights except in relation to a resolution proposing the variation of the rights attaching to such shares or a resolution proposing the winding-up of Investec PLC; and
 - no rights to dividends.

The Investec PLC Special Converting Shares may, prior to the occurrence of a Conversion Event, be redeemed at the discretion of the Investec PLC Board if it is necessary or expedient to ensure the Investec PLC Equivalent Number is in issue.

(b) After a Conversion Event

Upon the occurrence of a Conversion Event, each Special Converting Share of both companies will have the same rights as an ordinary share issued by the relevant company and will rank *pari passu* in all respects with the ordinary shares of that company.

For a summary of the principal provisions of the Investec PLC Special Converting Shares Trust Deed and the IGL Special Converting Shares Trust Deed, see paragraph 16 below.

13. IGL MEMORANDUM AND ARTICLES

Extracts from the IGL Articles are set out in Annexure XIV to this circular. See documents available for inspection in paragraph 20 of this circular regarding the availability of the IGL Memorandum and Articles for inspection.

14. INVESTEC PLC MEMORANDUM AND ARTICLES

The Investec PLC Memorandum and Articles contain equivalent provisions to those contained in the IGL Memorandum and Articles save to the extent that Applicable Regulation otherwise requires. See documents available for inspection in paragraph 20 of this circular regarding the availability of the Investec PLC Memorandum and Articles for inspection.

15. CONSTITUTIONAL DOCUMENTS OF THE TRUST COMPANIES

The memorandum and articles of association of UK Trust Co and SA Trust Co authorise the respective Trust Companies to enter into, exercise their powers and perform their obligations under the Voting Agreement, the Dividend Access Trust Deeds and the Special Converting Shares Trust Deeds.

16. SUMMARY OF DLC AGREEMENTS

16.1 DLC Agreements

The following comprise the DLC Agreements:

- (a) the Sharing Agreement;
- (b) the Voting Agreement;

- (c) the UK DAS Share Trust Deed;
- (d) the UK DAN Share Trust Deed;
- (e) the SA DAS Share Trust Deed;
- (f) the SA DAN Share Trust Deed;
- (g) the Investec PLC Special Converting Shares Trust Deed; and
- (h) the IGL Special Converting Shares Trust Deed.

The DLC Agreements are summarised below. See documents available for inspection in paragraph 20 of this circular for information on the availability of these documents for inspection.

16.2 The Sharing Agreement

The Sharing Agreement has been entered into between Investec PLC and IGL and is the primary agreement regulating the ongoing relationship of Investec PLC and IGL as dual listed companies.

(a) Regulation of the DLC Structure

Among other things, the Sharing Agreement regulates the following aspects of the DLC Structure:

- (i) the DLC Structure Principles (see paragraph 4 of this Annexure I for further details);
- (ii) the DLC Equalisation Principles (see paragraph 6 of this Annexure I for further details);
- (iii) the circumstances under which the Equalisation Ratio may be adjusted (see paragraph 6.1 of this Annexure I for further details);
- (iv) the circumstances under which Matching Actions may not be required (see paragraphs 6.2 and 6.3 of this Annexure I for further details);
- (v) the scope of, and procedure in relation to, Class Rights Actions (see paragraph 8.3 of this Annexure I for further details);
- (vi) the scope of, and procedure in relation to, Joint Electorate Actions (see paragraph 8.2 of this Annexure I for further details);
- (vii) the obligation on each of Investec PLC and IGL to enforce the change of control provisions in their constitutional documents (see paragraph 9.5 of this Annexure I for further details);
- (viii) the issue of the Equalisation Shares (see paragraph 7.5 of this Annexure I for further details); and
- (ix) the obligations on each of Investec PLC and IGL in relation to the Special Converting Shares including an obligation not to take any Action unless the Investec PLC Equivalent Number and the IGL Equivalent Number (as the case may be) is maintained and the requirement to make an application for listing following a Conversion Event (see paragraph 12.1 of this Annexure I for further details).

(b) Termination and Amendment

The circumstances in which the Sharing Agreement may be terminated are set out in paragraph 11 of this Annexure I. The circumstances in which it may be amended are set out in paragraph 8.3(a) of this Annexure I.

(c) Relationship to IGL Memorandum and Articles and Investec PLC Memorandum and Articles

If there is a conflict between the Sharing Agreement on the one hand and either the IGL Memorandum and Articles or the Investec PLC Memorandum and Articles on the other hand, Investec PLC and IGL are required to use their best endeavours to ensure that any required amendment to the IGL Memorandum and Articles or the Investec PLC Memorandum and Articles, as appropriate, is proposed at general meetings of Investec PLC and/or IGL in order to conform them with the provisions of the Sharing Agreement.

(d) Other Transactions

Subject to Applicable Regulation, the Sharing Agreement also obliges Investec PLC and IGL to enter into such further transactions or arrangements, and do such acts and things, as the other may reasonably require from time to time in the furtherance of the common interests of the holders of Investec PLC ordinary shares and holders of IGL ordinary shares or to give effect to the DLC Agreements.

16.3 Voting Agreement

The Voting Agreement has been entered into by Investec PLC, IGL, UK Trust Co (as holder of the Investec PLC Special Voting Share) and SA Trust Co (as holder of the IGL Special Converting Shares).

(a) *Voting procedures and the Trust Companies*

Among other things, the Voting Agreement sets out the following:

(i) *Notification Obligations*

The obligations of Investec PLC and IGL respectively to notify the Trust Companies:

- of the votes cast by Investec PLC shareholders and IGL members at general meetings (in the case of Joint Electorate Actions); and
- whether or not any resolution in relation to Class Rights Action was passed by the Required Majority (as defined in paragraph 8.3 of this Annexure I) of Investec PLC shareholders or IGL members;

(ii) *Voting Obligations*

The obligations of each of UK Trust Co and SA Trust Co to attend meetings and to vote respectively the Investec PLC Special Voting Share and the IGL Special Converting Shares and the obligations on SA Trust Co to provide written consent in respect of Class Rights Actions (see paragraph 8.3 of this Annexure I). Such obligations are to be carried out in accordance with the notification received from Investec PLC or IGL and the IGL Articles (as the case may be) pursuant to paragraph (i) above.

(iii) *Restrictions on transfer of the Investec PLC Special Voting Share and IGL Special Converting Shares*

A prohibition on the Trust Companies dealing in any way with the Investec PLC Special Voting Share and the voting rights attaching to the IGL Special Converting Shares or interests in or rights attaching to such shares unless approved as a Class Rights Action. UK Trust Co and SA Trust Co, may respectively transfer the Investec PLC Special Voting Share and the voting rights attaching to the IGL Special Converting Shares by giving not less than 90 days' notice provided that the transferee has been approved by Investec PLC and IGL, has agreed to be bound by the terms of the Voting Agreement and, in the case of a transfer by SA Trust Co, has agreed to be successor trustee under the IGL Special Converting Shares Trust Deed.

(iv) *Provision of information*

The obligations of Investec PLC and IGL to provide each of the Trust Companies with such information as they reasonably require (other than information which is of a price-sensitive nature and not generally available) for the purpose of discharging the powers, duties and discretion vested in them under the Voting Agreement.

(v) *Confidentiality*

The obligation of the Trust Companies to maintain the confidentiality of such information provided to it.

(vi) *Remuneration of Trust Companies*

The remuneration, which will be agreed between the parties from time to time, and expenses payable to the Trust Companies.

(vii) *Powers and discretions of Trust Companies*

The Trust Companies will have:

- all requisite power to take actions contemplated by the Voting Agreement, the Investec PLC Memorandum and Articles and the IGL Memorandum and Articles; and
- absolute uncontrolled discretion as to the exercise of such powers.

(viii) *Exclusion of responsibilities*

Exclusion of responsibility on the part of the Trust Companies:

- in respect of the exercise of their voting rights where IGL and/or Investec PLC have failed to comply in all material respects with their obligations to provide notification as regards the convening of, the matters to be considered at and the results of any general meetings at which the Trust Companies are required to vote;
- in respect of any discretion exercised reasonably and honestly;
- in respect of actions taken by them on the opinion or advice of or on information obtained from any lawyer, valuer, banker, accountant, the share registrars of Investec PLC or IGL or other expert;

- in circumstances where they have acted upon or have implemented or given effect to any resolution purporting to have been passed either as a resolution of Investec PLC shareholders or of IGL members; and
- in respect of them having accepted or acted or relied upon notices given to them by Investec PLC or IGL.

Neither Trust Company is required to take steps to ascertain whether any breach of the Voting Agreement has occurred and the Trust Companies may refrain from acting if they have not been supplied with all information they consider reasonably necessary to perform their obligations having requested the same.

(ix) *Indemnities*

Subject to certain exceptions (such as fraud, negligence or wilful default), indemnities in favour of the Trust Companies (and their directors, officers, employees, etc.) against all liabilities or expenses incurred by them in the execution of their obligations under the Voting Agreement.

(b) *Amendments*

The Voting Agreement may be amended by all the parties to it agreeing in writing.

The Trust Companies are generally required to concur with Investec PLC and IGL in amending the Voting Agreement provided the amendments are:

- (i) formal or technical amendments which the Boards of Investec PLC and IGL certify do not materially prejudice the interests of either Investec PLC shareholders or IGL members;
- (ii) amendments necessary to correct manifest errors or inconsistencies between the Voting Agreement and the Sharing Agreement; or
- (iii) amendments approved by Investec PLC shareholders and IGL members as a Class Rights Action, provided such amendments do not affect the obligations or rights of the Trust Companies.

(c) *Termination*

The Voting Agreement will terminate if the Sharing Agreement is terminated.

16.4 IGL Special Converting Shares Trust Deed

The IGL Special Converting Shares Trust Deed has been entered into between Investec PLC, IGL and SA Trust Co and governs the rights and obligations of the parties thereto in respect of the IGL Special Converting Shares prior to and following the occurrence of a Conversion Event.

Among other things, the IGL Special Converting Shares Trust Deed sets out the following:

(a) *Trust funds*

SA Trust Co is to hold the IGL Special Converting Shares on trust for the benefit of the Investec PLC shareholders. Each Investec PLC shareholder will be entitled to such proportion of the issued IGL Special Converting Shares as corresponds to the proportion of the Investec PLC ordinary shares in issue held by such Investec PLC shareholders (referred to as "Entitlement").

(b) *Distribution of the converted IGL Special Converting Shares following the occurrence of a Conversion Event*

- (i) IGL will inform SA Trust Co of the occurrence of a Conversion Event, provide details (including names, addresses, shareholdings and Entitlements) of each Investec PLC shareholder as at the Conversion Date and confirm whether or not SA Trust Co is to undertake the distribution or sale of the converted IGL Special Converting Shares. The circumstances in which IGL will confirm that no distribution or sale is to take place are likely to be where IGL or a Significant Bank in the IGL group is the subject of a Liquidation Event or an Insolvency Event.
- (ii) SA Trust Co will procure that the Investec PLC shareholders are notified of the occurrence of the Conversion Event and their Entitlement as at the Conversion Date.
- (iii) If SA Trust Co is to effect distribution and/or sale of the converted IGL Special Converting Shares, it will (unless IGL notifies it to the contrary) cause to be sent to each of the Investec PLC shareholders a form of certification. By completing and returning the form of certification, the Investec PLC shareholders will confirm whether or not they reside in a Restricted Jurisdiction.

- (iv) Once the IGL Special Converting Shares have been listed:
- in respect of any Investec PLC shareholder who has returned a form of certification confirming that he does not reside in a Restricted Jurisdiction (or if no form of certification is required), SA Trust Co will transfer to him his Entitlement as at the Conversion Date (less any shares which are sold to meet all fees, costs, taxes, duties and expenses arising out of the transfer);
 - in respect of any Investec PLC shareholder who has returned a form of certification confirming that he does reside in a Restricted Jurisdiction, SA Trust Co will sell, or procure the sale of, the converted Special Converting Shares of such Investec PLC shareholder and remit the proceeds (less any fees, commissions, costs, taxes and duties payable in relation to such sale).

If after the Conversion Date, an Investec PLC shareholder requests the transfer of the Special Converting Shares to which he is entitled, SA Trust Co shall be under no obligation to effect such transfer until such shareholder has placed funds with SA Trust Co for all fees, commissions, costs, taxes and duties relevant to such transfer.

(c) *Dividends following a Conversion Event*

Where a dividend falls to be paid by IGL in respect of the converted IGL Special Converting Shares on or after the Conversion Date but before all such shares have been transferred or sold by SA Trust Co, IGL will, on behalf of SA Trust Co, pay or procure the payment of such dividend to the relevant Investec PLC shareholders.

(d) *Untraced shareholders*

If there are converted IGL Special Converting Shares which have not been sold or distributed by SA Trust Co within six years of the Conversion Date, SA Trust Co will request that IGL places an advertisement in a national daily newspaper and a newspaper circulating in the area of the last known registered address of the relevant Investec PLC shareholders stating the intention to sell the shares. If any such shareholders have not made contact within three months of such advertisement being published, SA Trust Co will be entitled to sell the shares. The proceeds of sale will be paid to IGL, SA Trust Co will be entered as a creditor in the IGL books and the right to receive payment will become the trust property and will be held in trust for the relevant shareholders.

(e) *Delegation of operation*

Investec PLC and IGL agree as a term of the Trust that SA Trust Co has delegated to IGL and/or Investec PLC responsibility for:

- (i) the establishment of the identity of the Investec PLC shareholders and their Entitlements;
- (ii) the making of distributions on the IGL Special Converting Shares and the mechanics of such distributions; and
- (iii) obtaining instructions from Investec PLC shareholders.

In addition, the Trustee shall have no responsibility for any funds paid or property delivered as part of a distribution to Investec PLC shareholders. Such funds or property will not be segregated or marked as belonging to the Trustee or the shareholders and that the Trustee shall have no responsibility for monitoring such funds. Neither the Trustee nor the shareholders shall have any entitlement to interest or income arising from such funds or property pending their application.

The Trustee may require that any amounts paid as detailed above are held to its order and applied as it directs or that such amounts are paid to it directly. The Trustee is entitled to apply any such amounts to pay any sums owed under the indemnity described in paragraph (l) below.

(f) *Voting obligations*

The obligation of SA Trust Co to exercise the votes attaching to the IGL Special Converting Shares:

- (i) prior to the Conversion Date, in accordance with its obligations under the Voting Agreement; or
- (ii) after the Conversion Date and in respect of converted IGL Special Converting Shares which have not been sold or transferred by SA Trust Co, IGL shall seek directions of the relevant shareholders and SA Trust Co will vote, in accordance with the directions received provided that, in the absence of such instructions, SA Trust Co will have no obligation to vote the converted IGL Special Converting Shares.

(g) *Restriction on dealings with the IGL Special Converting Shares*

A prohibition on SA Trust Co from dealing with the IGL Special Converting Shares other than in accordance with the provisions of the IGL Special Converting Shares Trust Deed.

- (h) *Furnishing of information*
The obligation of SA Trust Co to furnish Investec PLC and/or IGL with such information regarding the affairs of the Trust as they may require. SA Trust Co shall keep such books and records as are necessary or appropriate, commensurate with its duties in relation to the Trust.
- (i) *Variations*
SA Trust Co will concur with Investec PLC and IGL in making changes to the IGL Special Converting Shares Trust Deed provided that those changes:
- (i) are formal or technical amendments which the Boards of Investec PLC and IGL have certified are not materially detrimental to the interests of the Investec PLC shareholders;
 - (ii) are necessary to correct any manifest error in the IGL Special Converting Shares Trust Deed or inconsistencies between its provisions and those of the Sharing Agreement; or
 - (iii) have been approved by Investec PLC shareholders and IGL members as a Class Rights Action.
- (j) *Redemption proceeds and the Trustee's remuneration and expenses*
If the Trustee receives the proceeds of the redemption of the IGL Special Converting Shares, it will retain such sums in a non-interest bearing bank account SA Trust Co may use such sums to reimburse Investec PLC and IGL for any fees and expenses paid or to be paid by IGL and Investec PLC to SA Trust Co for performing its services in relation to the Trust. The fees of SA Trust Co shall be agreed in writing between the parties. If any amounts remain in the bank account on the winding-up of the Trust, these sums shall be paid to SA Trust Co as a bonus payment.
- (k) *Liability of Trustee*
The exclusion of SA Trust Co's liability for any loss to any person as a result of any exercise of its power or discretion pursuant to the IGL Special Converting Shares Trust Deed unless such loss results from its own fraud, wilful default or negligence.
- (l) *Indemnity*
An indemnity in favour of SA Trust Co (and its directors, officers, employees etc.), given by Investec PLC and IGL, against all liabilities (excluding those which arise from its own fraud, wilful default or negligence or that of its directors, officers, employees etc.) incurred in the execution of its obligations under the IGL Special Converting Shares Trust Deed.
- (m) *Change of Trustee*
IGL has the power to appoint new and/or additional trustees and the transfer of such powers in full to Investec PLC if IGL goes into liquidation and SA Trust Co has the right to retire in accordance with the provisions of the IGL Special Converting Shares Trust Deed. IGL may remove SA Trust Co as trustee if SA Trust Co has breached any term of the IGL Special Converting Shares Deed or such removal has been approved as a Class Rights Action.
- (n) *Powers of Trustee*
SA Trust Co will be entitled to deal with the IGL Special Converting Shares for the purposes of achieving the objects of the Trust in accordance with the terms set out in the IGL Special Converting Shares Trust Deed and to do all such things lawful to facilitate the administration of the Trust.
- (o) *Exclusion of responsibilities*
SA Trust Co will not be responsible for, amongst other things, the following:
- (i) actions taken by it on the opinion or advice of or any information obtained from any lawyer, valuer, banker, accountant or other expert;
 - (ii) anything done having accepted or acted or relied upon notices given to it from Investec PLC and/or IGL;
 - (iii) failure to fulfil any duties or obligations which are not expressly specified in the IGL Special Converting Shares Trust Deed;
 - (iv) incurring any financial liability in connection with the performance of its rights and obligations where it has reasonable grounds to believe that reimbursement of such financial liability is not guaranteed;
 - (v) actions of agents it has appointed;

- (vi) actions of any person it has delegated duties to;
 - (vii) the validity or suitability of the IGL Special Converting Shares Trust Deed or any other document or any liability to any person because of the invalidity or unsuitability of such documents; and
 - (viii) any liabilities arising from the exercise of its functions provided that such liabilities do not result from its own wilful default, fraud or negligence.
- (p) *Trustee discretion*
SA Trust Co shall have an absolute and uncontrolled discretion as to the exercise of its functions.
- (q) *Unlawful action*
SA Trust Co has the right to refrain from doing anything that it reasonably believes to constitute an unlawful action or otherwise render it liable to any person and to do anything necessary to comply with any legal requirement.

16.5 Investec PLC Special Converting Shares Trust Deed

The Investec PLC Special Converting Shares Trust Deed contains corresponding provisions to the IGL Special Converting Shares Trust Deed save in relation to voting. Prior to the occurrence of a Conversion Event, the Investec PLC Special Converting Shares will only have voting rights in respect of variations of the rights attaching to such shares or on a winding-up of Investec PLC (see paragraph 12.2(a)(ii) of this Annexure I). If such a resolution is proposed, UK Trust Co must, if due notification has been given, vote in favour of or give its written consent to the resolution, where such resolution has been approved either as a Class Rights Action or a Joint Electorate Action (as the case may be), or vote against, or withhold its consent to, a resolution, where such resolution has been defeated as a Class Rights Action or a Joint Electorate Action (as the case may be).

16.6 UK DAS Share Trust Deed

The UK DAS Share Trust Deed will be entered into between Investec PLC, IGL and UK Trust Co (as holder of the UK DAS Share) for the purposes of facilitating the payment of dividends by Investec PLC to South African IGL members through UK Trust Co, in circumstances where IGL will not be paying such shareholders the required dividend in full. UK Trust Co is to hold the UK DAS Share on trust for each South African resident IGL member. Each South African IGL member will be entitled to such amount of the dividend as would bear the same proportion to the total dividend as the number of IGL ordinary shares he holds bears to the aggregate number of IGL ordinary shares held by South African IGL members (in each case as at the record date) ("Entitlement").

Among other things, the UK DAS Share Trust Deed sets out the following:

- (a) *Payment of dividends*
Following a declaration by Investec PLC of a dividend on the UK DAS Share:
- (i) Investec PLC will notify UK Trust Co of such declaration; and
 - (ii) Investec PLC will, on behalf of UK Trust Co, effect the distribution of such dividends to the South African resident IGL members, in accordance with their respective Entitlements.
- (b) *Delegation of operation*
IGL and Investec PLC agree as a term of the Trust that the Trustee has delegated to IGL and Investec PLC responsibility for:
- (i) the establishment of the identity of the IGL members and their Entitlements; and
 - (ii) the payment or delivery of dividends and the mechanics for effecting such payment or delivery.

In addition, the Trustee shall have no responsibility for funds paid or property delivered to IGL members. Such funds or property will not be segregated or marked as belonging to the Trustee or members and the Trustee shall have no responsibility for monitoring such funds. Neither the Trustee nor the members shall have any entitlement to interest or income arising from such funds or property.

The Trustee may require that any amounts paid as detailed above are held to its order and applied as it directs or that such amounts are paid to it directly. The Trustee is entitled to apply such amounts to pay any sums owned under the indemnity provided to the Trustee by Investec PLC and IGL pursuant to the UK DAS Share Trust Deed (see paragraph (e) below).

(c) *Unclaimed dividends*

If any part of a dividend has not been paid within six years from the date it was declared or became due for payment, the Entitlements of the relevant IGL members to such dividends will be forfeited in accordance with the Investec PLC Articles.

(d) *Voting*

The UK DAS Share only has voting rights in respect of variations of the rights attaching to such share or on a winding-up of Investec PLC. In relation to any such resolution, UK Trust Co must, if due notification has been given, exercise the votes attaching to the UK DAS Share in favour of or give its written consent to the resolution, where such resolution has been approved as either a Class Rights Action or a Joint Electorate Action (as the case may be) and exercise the votes against or withhold its consent to the resolution, where such resolution has been defeated either as a Class Rights Action or a Joint Electorate Action (as the case may be).

(e) *Other provisions*

The UK DAS Share Trust Deed contains provisions corresponding to those under the IGL Special Converting Shares Trust Deed detailed under paragraphs 16.4(f) to (q).

16.7 UK DAN Share Trust Deed

The UK DAN Share Trust Deed will be entered into between Investec PLC, IGL and UK Trust Co (as holder of the UK DAN Share) for the purposes of facilitating the payment of dividends by Investec PLC to non-South African resident IGL members through UK Trust Co, in circumstances where IGL will not be paying such members the required dividend in full.

The UK DAN Share Trust Deed contains corresponding provisions to the UK DAS Share Trust Deed.

16.8 SA DAS Share Trust Deed

The SA DAS Share Trust Deed will be entered into between Investec PLC, IGL and SA Trust Co (as holder of the SA DAS Share) for the purposes of facilitating the payment of dividends by IGL to South African resident Investec PLC shareholders through SA Trust Co, in circumstances where Investec PLC will not be paying such shareholders the required dividend in full.

The SA DAS Share Trust Deed contains corresponding provisions to the UK DAS Share Trust Deed but will be governed by South African law and all disputes will be referred to arbitration.

16.9 SA DAN Share Trust Deed

The SA DAN Share Trust Deed will be entered into between Investec PLC, IGL and SA Trust Co (as holder of the SA DAN Share) for the purposes of facilitating the payment of dividends by IGL to the non-South African Investec PLC shareholders through SA Trust Co, in circumstances where Investec PLC will not be paying such shareholders the required dividend in full.

The SA DAN Share Trust Deed contains corresponding provisions to the UK DAS Share Trust Deed, but will be governed by South African law and all disputes will be referred to arbitration.

17. CORPORATE SERVICES AGREEMENT

The Corporate Services Agreement will be entered into between Investec PLC, IGL and Trust Corporation. The agreement imposes the following obligations:

(a) *DLC Agreements*

Trust Corporation is to procure compliance of the Trust Companies with their respective obligations under the Voting Agreement, Dividend Access Trust Deeds and Special Converting Shares Trust Deeds and ensure that the only activities the Trust Companies perform are those necessary or expedient in order for such Trust Companies to fulfil such obligations.

(b) *Trust Company administration*

Trust Corporation is to maintain the accounts and corporate records for the Trust Companies and ensure that all necessary filings are made in relation thereto and arrange for the filing of all tax returns.

(c) *Trust Company directors*

Trust Corporation is to ensure that suitable persons are appointed to act as directors of the Trust Companies.

(d) *Trust Company shares*

Trust Corporation is not to transfer or otherwise deal with the shares in the Trust Companies unless otherwise agreed by IGL and Investec PLC (such agreement not to be unreasonably withheld or delayed).

(e) *Indemnities*

IGL and Investec PLC indemnify the Trust Corporation, and officers of the Trust Corporation and Trust Companies against all liabilities arising in respect of holding the shares in the Trust Companies or holding office in relation to the Trust Companies (in the absence of fraud, wilful default or negligence).

(f) *Limitation of liability*

The obligations of Trust Corporation are corporate obligations and recourse shall not be sought against its employees, officers or shareholders.

HISTORIC FINANCIAL INFORMATION RELATING TO INHOLD

Set out below is the historic financial information relating to Inhold as extracted from the annual financial statements of Inhold for the year ended 31 March 2001. The auditors' reports on the financial statements of Inhold for the years ended 31 March 2001 and 31 March 2000 were issued without qualification.

I. BALANCE SHEETS

R'million At 31 March	2001	Group 2000
ASSETS		
Cash and short-term funds	69 187	73 118
Short-term negotiable securities	53 874	39 043
Investment and trading securities	22 144	17 765
Other assets	6 570	7 426
Advances	38 008	33 003
Associated companies	544	349
Fixed assets	1 320	1 067
Goodwill	2 849	2 443
	194 496	174 214
EQUITY AND LIABILITIES		
Capital and reserves		
Ordinary share capital	4	4
Compulsorily convertible debentures	2 321	1 710
Reserves	2 574	2 594
	4 899	4 308
Interest of minority shareholders in subsidiaries	3 587	3 555
	8 486	7 863
Subordinated debt	1 945	–
Cumulative redeemable preference shares	382	–
	10 813	7 863
Liabilities		
Deposits and other accounts	183 018	165 679
Taxation	304	361
Shareholders for ordinary dividend	361	311
	194 496	174 214

2. INCOME STATEMENTS

R'million	Group	
For the year ended 31 March	2001	2000
Interest received	12 120	9 006
Interest paid	10 244	7 608
Net interest income	1 876	1 398
Provision for bad and doubtful debts	198	211
	1 678	1 187
Other income	3 627	3 230
Total income	5 305	4 417
Operating expenses	3 476	2 864
Income before exceptional items	1 829	1 553
Exceptional items	312	165
Income before taxation	1 517	1 388
Taxation	326	352
Income after taxation	1 191	1 036
Share of (loss)/income of associated companies	(86)	42
Operating income	70	106
Exceptional items	(156)	(64)
Net income	1 105	1 078
Earnings attributable to minority shareholders	484	468
	621	610
Preference dividends	24	1
Compulsorily convertible debenture interest	247	245
Earnings attributable to ordinary shareholders	350	364
Earnings per share (cents)	859,0	892,6
Headline earnings per share (cents)	1 368,7	1 143,0
Diluted earnings per share (cents)	859,0	892,6
Dividends per share (cents)	680,0	560,0
Headline earnings attributable to ordinary shareholders		
Calculation of headline earnings		
Earnings attributable to ordinary shareholders	350	364
Headline adjustments	468	229
Share of associates' exceptional items	156	64
Goodwill amortised	315	195
Discount on fair value of acquisitions	(3)	(30)
Minority share of headline adjustments	(260)	(127)
Headline earnings	558	466

3. CASH FLOW STATEMENTS

R'million For the year ended 31 March	Group 2001	2000
Cash retained/(utilised) from operating activities		
Cash generated by operating activities	2 171	1 892
Dividends received from associated companies	18	55
Taxation paid	(352)	(152)
Cash available from operating activities	1 837	1 795
Dividends paid	(568)	(438)
Compulsorily convertible debenture interest paid	(247)	(245)
Preference dividends paid	(24)	(1)
Net cash inflow from operating activities	998	1 111
Cash (utilised)/generated in investing activities		
Net funds (utilised)/arising on acquisitions	(747)	5 810
Net investment in associated companies	(300)	–
Net investment in fixed assets	(376)	(242)
Net cash (outflow)/inflow from investing activities	(1 423)	5 568
Cash flows from banking activities		
Movement in deposits and other accounts	9 658	42 520
Movement in income earning assets	(17 518)	(13 373)
Net cash (outflow)/inflow from banking activities	(7 860)	29 147
Cash flows from assurance activities		
Movement in long term assurance fund and other liabilities	4 837	1 837
Movement in assurance related assets	(4 818)	(1 834)
Net cash inflow from assurance activities	19	3
Cash flows from financing activities		
Proceeds on issue of subsidiary ordinary shares to minority shareholders	15	12
Net proceeds on issue of convertible debentures	629	–
Issue/(redemption) of redeemable preference shares	382	(15)
Issue of bonds	1 945	–
Net cash inflow from financing activities	2 971	(3)
Net (decrease)/increase in cash and short-term funds	(5 295)	35 826
Cash and short-term funds at beginning of year (Note 23.7)	74 482	37 292
Cash and short term funds at end of year	69 187	73 118
Note 23.7:		
Cash and short-term funds – opening balance		
Cash and short-term funds	73 118	36 699
Effect of exchange rate changes	1 364	593
	74 482	37 292

4. STATEMENT OF CHANGES IN SHAREHOLDERS' FUNDS

R'million For the year ended 31 March	2001	Group 2000
Share capital		
Balance at beginning of year	4	4
Issue of shares	–	–
Balance at end of year	4	4
Compulsorily convertible debentures		
Balance at beginning of year	1 710	1 715
Issues of debentures	629	–
Conversion to ordinary shares of subsidiary	(18)	(5)
Balance at end of year	2 321	1 710
Share premium		
Balance at beginning of year	1 484	1 484
Issue of shares-net of issue expense	–	–
Balance at end of year	1 484	1 484
General reserves		
Balance at beginning of year	800	651
Earnings attributable to ordinary shareholders	350	364
– As previously reported	–	392
– Prior year adjustments	–	(28)
Transfer from equity accounted reserves	47	6
Dividends	(277)	(228)
Transfer from (to) interest of minority shareholders	10	(4)
Transfer (to) from secondary reserves	(7)	11
Balance at end of year	923	800
Secondary reserves		
Balance at beginning of year	255	193
Transfer from (to) general reserves	7	(11)
Movement in revaluations	(103)	73
Balance at end of year	159	255
Equity accounted reserves of associated companies		
Balance at beginning of year	55	61
Transfer to retained income	(47)	(6)
Balance at end of year	8	55
Total	4 899	4 308

5. ACCOUNTING POLICIES

The accounting policies of Inhold are the same as those of IGL. In this regard Inhold members are referred to the accounting policies for IGL as set out in paragraph 5 of Annexure VI to this document.

PUBLISHED AUDITED RESULTS OF INHOLD FOR THE YEAR ENDED 31 MARCH 2002

Investec Holdings Limited

Audited Group Results for the year ended 31 March 2002

- 23rd Year of Uninterrupted Growth
- Headline Earnings \uparrow 8.9%

- Headline Earnings Per Share \uparrow 15.0%
- 10-Year Compound Growth in Headline EPS 31.3%

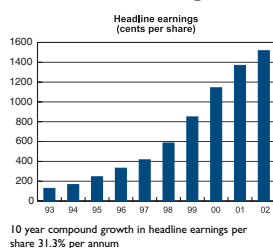

Salient Features			
	31 March 2002	31 March 2001	% Increase
Headline earnings attributable to ordinary shareholders (R' millions)	609	559	8.9
Headline earnings per share (cents)	1 574.3	1 368.7	15.0
Dividends declared per share (cents)	750	680	10.3
Weighted average number of ordinary shares in issue (millions)	38.7	40.8	

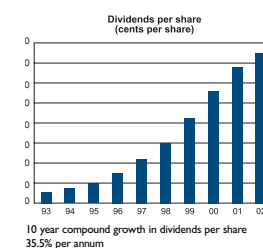

Consolidated Income Statement

(R' Millions)	31 March 2002	31 March 2001*	% Increase
Interest received	12 437	12 120	2.6
Interest paid	10 290	10 268	0.2
Provision for bad and doubtful debts	202	198	2.0
Net interest income	1 945	1 654	17.6
Other income	5 279	3 627	45.6
Total income	7 224	5 281	36.8
Operating expenses	4 885	3 476	40.5
Exceptional items	1 013	312	224.7
Income before taxation	1 326	1 493	(11.2)
Taxation	422	326	29.5
Income after taxation	904	1 167	(22.5)
Share of income/(loss) of associated companies	17	(86)	119.8
Operating income	62	70	(11.4)
Exceptional items	(45)	(156)	
Net income	921	1 081	(14.8)
Attributable to minority shareholders	404	483	(16.4)
Debt interest	517	598	(13.2)
Earnings attributable to ordinary shareholders	212	351	(39.6)
Headline earnings per share (cents)	1 574.3	1 368.7	15.0
Earnings per share (cents)	548.4	860.9	(36.3)
Diluted earnings per share (cents)	548.4	860.9	(36.3)
Dividends per share (cents) per AC104	740.0	627.5	17.9

Calculation of Headline Earnings

(R' Millions)	31 March 2002	31 March 2001*
Headline earnings	609	559
Exceptional items	(1 058)	(468)
Minority share of exceptional items	661	260
Attributable earnings	212	351

Statement of Changes in Shareholder's Equity

(R' Millions)	31 March 2002	31 March 2001*
Balance at beginning of period	5 063	4 449
Net issue of shares and debentures	(4)	611
Repurchase of own shares	(607)	—
Change in shareholding in subsidiary	995	—
Earnings attributable to ordinary shareholders	212	351
Dividends paid	(289)	(255)
Movement in other reserves	571	(93)
Balance at end of period	5 941	5 063

*Restated for changes to accounting policies and disclosures

Certain statements contained in this announcement constitute "forward-looking statements". These statements, which contain the words "anticipate", "believe", "intend", "estimate", "expect" and words of similar meaning, reflect the Director's beliefs and expectations and are subject to risks and uncertainties that may cause actual results to differ materially. As a result, readers are cautioned not to place undue reliance on such forward-looking statements. The Company disclaims any obligation to update its view of such risks and uncertainties or to publicly announce the result of any revisions to the forward-looking statements made herein, except where it would be required to do so under applicable law.

Consolidated Balance Sheet

(R' Millions)	31 March 2002	31 March 2001*
Assets		
Cash and short term funds	111 224	69 176
Short term negotiable securities	64 738	53 874
Investment and trading securities	17 917	9 968
Other assets	9 020	6 255
Advances	54 345	38 008
Associated companies	503	544
Fixed assets	2 499	1 320
Goodwill	5 485	2 849
Long-term assurance assets attributable to policyholders	38 042	12 702
	303 773	194 696
Equity and liabilities		
Capital and reserves		
Ordinary share capital	2	4
Compulsorily convertible debentures	2 317	2 321
Reserves	3 622	2 738
	5 941	5 063
Interest of minority shareholders in subsidiaries	7 343	3 784
Total shareholders' funds	13 284	8 847
Subordinated debt	2 245	1 945
Redeemable preference shares	382	382
Total capital resources	15 911	11 174
Liabilities		
Deposits and other accounts	249 302	170 316
Taxation	518	504
Long-term assurance liabilities attributable to policyholders	38 042	12 702
	303 773	194 696
Acceptances, guarantees and letters of credit	13 226	11 368

Abridged Cash Flow Statement

(R' Millions)	31 March 2002	31 March 2001*
Cash retained/(utilised) from operating activities	25 965	(6 854)
Cash utilised in investing activities	(1 649)	(1 423)
Cash flows from financing activities	(307)	2 971
Net increase/(decrease) in cash and short term funds	24 009	(5 306)
Cash and short term funds at beginning of period	69 176	73 118
Effect of exchange rates in opening balance of cash and short term funds	18 039	1 364
Cash and short term funds at end of period	111 224	69 176

*Restated for changes to accounting policies and disclosures

Commentary

This report has been prepared in compliance with South African Statements of Generally Accepted Accounting Practice. Accounting policies are consistent with those of the previous year, except where indicated otherwise.

The results of Investec Holdings Limited ("Inhold") reflect the performance of the company's subsidiary Investec Group Limited ("Investec"). Inhold shareholders are referred to Investec's announcement for further details regarding the Group's results.

During the year under review Inhold repurchased and cancelled 3 754 500 of its own shares for a consideration of R607 million.

On 22 November 2001, Investec announced that it would pursue a listing on the London Stock Exchange ("LSE") and JSE Securities Exchange South Africa ("JSE") using a Dual Listed Companies Structure.

Consequently the Inhold pyramid structure will no longer be appropriate due to the changed circumstances and it is therefore intended that Inhold will unbundle its assets and delist from the JSE.

A detailed announcement will be made in due course.

On behalf of the board

I R Kantor
Chairman

23 May 2002

Dividend announcement

A final dividend (No. 32) of 410.0 cents (2001 – 400.0 cents) per ordinary share has been declared in respect of the year ended 31 March 2002.

The last day to trade cum dividend will be Friday 7 June 2002. The shares will commence trading ex dividend on Monday 10 June 2002. The record date will be Friday 14 June 2002. Payment will be made on Tuesday 18 June 2002.

Share certificates may not be dematerialised or rematerialised between Monday 3 June and Friday 14 June 2002, both dates inclusive.

By order of the board

S Noik
Secretary

23 May 2002

Registered office:
100 Grayston Drive, Sandown, Sandton 2196.

Transfer secretaries:
Computershare Investor Services Limited, 8th Floor,
11 Diagonal Street, Johannesburg 2001.

Directors:
I R Kantor (Chairman), B Kardol (Deputy Chairman), G R Burger, G H Davin,
H S Herman, B Kantor, S Koseff, P R S Thomas,
A Dutch

 **Investec**
Holdings Limited

Investec Holdings Limited
("Inhold")
(Registration Number 1985/005574/06)
JSE Code: INH ISIN: ZAE00003562

PRO FORMA FINANCIAL INFORMATION RELATING TO INHOLD

Set out below, for illustrative purposes only, is the pro forma financial information relating to Inhold subsequent to the Inhold reorganisation, the Inhold unbundling and the Inhold winding-up and based on the published audited balance sheet of Inhold at 31 March 2002:

I. PRO FORMA NET ASSET STATEMENT RELATING TO INHOLD

R'million At 31 March 2002	Before As published	Inhold reorganisation Adjustments					After the Inhold reorgani- sation	Inhold unbundling	After the Inhold unbundling and the Inhold winding-up
		1	2	3	4	5			
ASSETS									
Cash and short term funds	111 224	505	(72)	(382)	(5)		111 270	(111 270)	–
Short term negotiable securities	64 738						64 738	(64 738)	–
Investment and trading securities	17 917						17 917	(17 917)	–
Other assets	9 020						9 020	(9 020)	–
Advances	54 345		(14)				54 331	(54 331)	–
Associated companies	503						503	(503)	–
Fixed assets	2 499						2 499	(2 499)	–
Goodwill	5 485						5 485	(5 485)	–
Long-term assurance assets attributable to policyholders	38 042						38 042	(38 042)	–
	303 773	505	(86)	(382)	(5)		303 805	(303 805)	–
EQUITY AND LIABILITIES									
Capital and reserves									
Ordinary share capital	2						2	(2)	–
Compulsorily convertible debentures	2 317						2 317	(2 317)	–
Reserves	3 622	148	(8)			32	3 794	(3 794)	–
	5 941	148	(8)	–	–	32	6 113	(6 113)	–
Interest of minority shareholders in subsidiaries	7 343	357				(32)	7 668	(7 668)	–
Total shareholders' funds	13 284	505	–	–	–	–	13 781	(13 781)	–
Subordinated debt	2 245						2 245	(2 245)	–
Redeemable preference shares	382			(382)			–	–	–
Total capital resources	15 911	505	(8)	(382)	–	–	16 026	(16 026)	–
Liabilities									
Deposits and other accounts	249 302		(78)				249 224	(249 224)	–
Taxation	518				(5)		513	(513)	–
Long-term assurance liabilities attributable to policyholders	38 042						38 042	(38 042)	–
	303 773	505	(86)	(382)	(5)	–	303 805	(303 805)	–
Number of shares in issue									
	37 015 295						37 015 295	37 015 295	–

Adjustments

The adjustments in terms of the Inhold reorganisation, as detailed in paragraph 4.1 of this circular, are as follows:

1. 2 985 176 IGL ordinary shares held by Inhold were sold by Inhold for a total amount of R505 million. This enabled Inhold to redeem the preference shares referred to in 3 below and to settle its liabilities.
2. Collection of accounts receivable and settlement of liabilities.
3. Redemption at par of the 800 redeemable preference shares issued by Inhold.
4. Settlement of Inhold's taxation liability.
5. Delivery by Fintique II and Fintique III of IGL ordinary shares as a penalty for cancellation of the sale agreements.

Assumptions

1. The Inhold reorganisation, the Inhold unbundling and the Inhold winding-up were implemented on 31 March 2002.
2. An exchange rate of R16,1577251:£1 has been used, being the closing R:£ exchange rate on 31 March 2002.
3. The number of Inhold ordinary shares in the before column has been based on the actual number of shares in issue as at 31 March 2002.
4. The residual assets remaining in Inhold after the unbundling are sufficiently small such that no further distributions will be made to Inhold members.
5. No account has been taken of any costs associated with the Inhold reorganisation, the Inhold unbundling or the Inhold winding-up.

2. PRO FORMA FINANCIAL EFFECT OF THE INHOLD REORGANISATION AND THE INHOLD UNBUNDLING ON THE HEADLINE EARNINGS PER INHOLD ORDINARY SHARE

Set out below are the pro forma financial effects of the Inhold reorganisation and the Inhold unbundling on the headline earnings per Inhold ordinary share for the financial year ended 31 March 2002:

At 31 March 2002	Before as published (cents)	After the Inhold reorganisation (Note 1) (cents)	Percentage change (%)	After the Inhold unbundling (Note 2) (cents)	Percentage change (%)
Headline earnings per share	1 574.3	1 596.2	1.4	1 583.5	(0.8)

Note 1:

The calculation of the pro forma financial effects of the Inhold reorganisation on the headline earnings per Inhold ordinary share is based on the adjustments and assumptions used in the pro forma net asset statement relating to Inhold in 1 above and assumes that the Inhold reorganisation was implemented on 1 April 2002.

Note 2:

The headline earnings per IGL ordinary share for the year ended 31 March 2002 were 1 840.4 cents. The "After the Inhold unbundling" column is based on an Inhold member's entitlement of 0.8604 of an IGL ordinary share for each Inhold ordinary share held on the record date for the Inhold unbundling.

3. EFFECT OF THE INHOLD UNBUNDLING ON THE MARKET VALUE PER INHOLD ORDINARY SHARE

The closing share price of an Inhold ordinary share on Friday, 31 May 2002, being the last practicable day prior to the finalisation of this circular, was R144.00 and the closing share price of an IGL ordinary share on the same date was R170.00. Based on an Inhold member's entitlement of 0.8604 of an IGL ordinary share for each Inhold ordinary share held on the record date for the Inhold unbundling, an Inhold member's entitlement to IGL ordinary shares in terms of the Inhold unbundling represents an increase of 1.6% in the market value per Inhold ordinary share on Friday, 31 May 2002.

REPORTING ACCOUNTANTS' REPORT ON THE PRO FORMA FINANCIAL INFORMATION RELATING TO INHOLD

"The Directors
Investec Holdings Limited
PO Box 785700
Sandton
2146

14 June 2002

Gentlemen

INDEPENDENT REPORTING ACCOUNTANTS' REPORT IN RESPECT OF THE UNAUDITED PRO FORMA FINANCIAL INFORMATION ("pro forma financial information") RELATING TO INVESTEC HOLDINGS LIMITED ("Inhold") ("the Inhold pro forma financial information")**Introduction**

We report on the Inhold pro forma financial information after the Inhold reorganisation, the Inhold unbundling and the Inhold winding-up (each of which terms is defined in the circular to Investec Group Limited members and Inhold members of which this report forms part ("the circular")), as set out in Annexure IV of the circular. The Inhold pro forma financial information has been prepared for illustrative purposes only and only to provide information about how the transaction contemplated above might have impacted on Inhold's financial information presented.

At your request and for the purposes of compliance with the Listings Requirements of the JSE Securities Exchange South Africa, relating to the above, we present our report on the Inhold pro forma financial information.

Responsibilities

The compilation, contents and presentation of the circular are the responsibility of the directors of Inhold. Our responsibility is to form an opinion on the Inhold pro forma financial information as set out in Annexure IV of the circular.

We do not accept responsibility for any reports previously given by us on any financial information used in the compilation of the Inhold pro forma financial information included in the said circular, beyond that owed to those to whom those reports were addressed by us at the dates of their issue.

Basis of opinion

Our work, which did not involve any independent examination of any of the underlying financial information, consisted primarily of agreeing the financial information presented with the published audited financial position and financial results of Inhold, considering evidence supporting the adjustments to that information and discussing the Inhold pro forma financial information and effects with the directors of Inhold.

Because the above procedures do not constitute either an audit or a review made in accordance with South African Auditing Standards, other matters might have come to our attention that would have been reported to you.

Opinion

In our opinion:

- the Inhold pro forma financial information has been properly compiled on the basis stated;
- such basis is consistent with the accounting policies of Inhold; and

- the adjustments are appropriate for the purpose of the Inhold pro forma financial information as disclosed and in terms of the Inhold reorganisation, the Inhold unbundling and the Inhold winding-up (each of which terms is defined in the circular:

We consent to the inclusion of this report in the circular to Investec Group Limited members and Inhold members to be issued on or about 20 June 2002 in the form and context in which it appears therein and we confirm that we have not withdrawn that consent prior to the issue of the said circular.

Yours faithfully

Ernst & Young''

HISTORIC FINANCIAL INFORMATION RELATING TO IGL

Set out below is the historic financial information relating to IGL as extracted from the annual financial statements of IGL for the year ended 31 March 2001. The auditors' reports on the financial statements of IGL for the years ended 31 March 2001 and 31 March 2000 were issued without qualification.

I. BALANCE SHEETS

R'million At 31 March	2001	Group 2000
ASSETS		
Cash and short-term funds	69 187	73 118
Short-term negotiable securities	53 874	39 043
Investment and trading securities	22 144	17 765
Other assets	6 552	7 426
Advances	38 062	33 034
Associated companies	544	349
Fixed assets	1 320	1 065
Goodwill	2 849	2 443
	194 532	174 243
EQUITY AND LIABILITIES		
Capital and reserves		
Ordinary share capital	49	48
Compulsorily convertible debentures	2 321	1 710
Convertible preference shares	385	–
Reserves	5 917	5 846
	8 672	7 604
Interest of minority shareholders in subsidiaries	267	291
Total shareholders' funds	8 939	7 895
Subordinated debt	1 945	–
	10 884	7 895
Liabilities		
Deposits and other accounts	182 994	165 679
Taxation	298	361
Shareholders for ordinary dividend	356	308
	194 532	174 243

2. INCOME STATEMENTS

R'million	Group	
For the year ended 31 March	2001	2000
Interest received	12 114	9 006
Interest paid	10 236	7 608
Net interest income	1 878	1 398
Provision for bad and doubtful debts	198	211
	1 680	1 187
Other income	3 621	3 230
Total income	5 301	4 417
Operating expenses	3 476	2 864
Income before exceptional items	1 825	1 553
Exceptional items	312	165
Income before taxation	1 513	1 388
Taxation	321	352
Income after taxation	1 192	1 036
Share of (loss)/income of associated companies	(86)	42
Operating income	70	106
Exceptional items	(156)	(64)
Net income	1 106	1 078
Earnings attributable to minority shareholders	13	15
	1 093	1 063
Compulsorily convertible debenture interest	247	245
Earnings attributable to ordinary shareholders	846	818
Earnings per share (cents)	1 048,4	1 016,4
Headline earnings per share (cents)	1 628,2	1 300,9
Diluted earnings per share (cents)	1 039,7	1 016,1
Dividends per share (cents)	750,0	620,0
Headline earnings attributable to ordinary shareholders		
Calculation of headline earnings		
Earnings attributable to ordinary shareholders	846	818
Headline adjustments	468	229
Share of associates' exceptional items	156	64
Goodwill amortised	315	195
Discount on fair value of acquisitions	(3)	(30)
Headline earnings	1 314	1 047

3. CASH FLOW STATEMENTS

R'million For the year ended 31 March	Group 2001	2000
Cash retained/(utilised) from operating activities		
Cash generated by operating activities	2 167	1 892
Dividends received from associated companies	18	55
Taxation paid	(353)	(152)
Cash available from operating activities	1 832	1 795
Dividends paid	(558)	(432)
Compulsorily convertible debenture interest paid	(247)	(245)
Net cash inflow from operating activities	1 027	1 118
Cash (utilised)/generated in investing activities		
Net funds (utilised)/arising on acquisitions	(747)	5 810
Net investment in associated companies	(300)	–
Net investment in fixed assets	(376)	(242)
Net cash (outflow)/inflow from investing activities	(1 423)	5 568
Cash flows from banking activities		
Movement in deposits and other accounts	9 632	42 522
Movement in income earning assets	(17 524)	(13 397)
Net cash (outflow)/inflow from banking activities	(7 892)	29 125
Cash flows from assurance activities		
Movement in long term assurance fund and other liabilities	4 837	1 837
Movement in assurance related assets	(4 818)	(1 834)
Net cash inflow from assurance activities	19	3
Cash flows from financing activities		
Proceeds on issue of ordinary shares and conversion of debentures	15	12
Net proceeds on issue of convertible debentures	629	–
Issue of convertible preference shares	385	–
Issue of bonds	1 945	–
Net cash inflow from financing activities	2 974	12
Net (decrease)/increase in cash and short-term funds		
Cash and short-term funds at beginning of year (Note 23.7)	74 482	37 292
Cash and short-term funds at end of year	69 187	73 118
Note 23.7:		
Cash and short-term funds – opening balance		
Cash and short-term funds	73 118	36 699
Effect of exchange rate changes	1 364	593
	74 482	37 292

4. STATEMENT OF CHANGES IN SHAREHOLDERS' FUNDS

R'million For the year ended 31 March	2001	Group 2000
Ordinary share capital		
Balance at beginning of year	48	48
Issue of shares	1	–
Balance at end of year	49	48
Compulsorily convertible debentures		
Balance at beginning of year	1 710	1 715
Issues of debentures	629	–
Conversion to ordinary shares	(18)	(5)
Balance at end of year	2 321	1 710
Convertible preference shares		
Balance at beginning of year	–	–
Issue of convertible preference shares	460	–
Less: Liability portion transferred to deposits and other accounts	(75)	–
Balance at end of year	385	–
Share premium		
Balance at beginning of year	3 951	3 934
Issue of shares-net of issue expense	40	12
Conversion from debentures	18	5
Balance at end of year	4 009	3 951
General reserves		
Balance at beginning of year	1 168	811
Earnings attributable to ordinary shareholders	846	818
– As previously reported	–	882
– Prior year adjustments	–	(64)
Transfer from equity accounted reserves	104	14
Dividends	(606)	(499)
Transfer (to) from secondary reserves	(16)	24
Balance at end of year	1 496	1 168
Secondary reserves		
Balance at beginning of year	604	462
Transfer from (to) general reserves	16	(24)
Movement in revaluations	(227)	166
Balance at end of year	393	604
Equity accounted reserves of associated companies		
Balance at beginning of year	123	137
Transfer to retained income	(104)	(14)
Balance at end of year	19	123
Total	8 672	7 604

5. ACCOUNTING POLICIES

The annual financial statements have been prepared on the historical cost basis, unless otherwise indicated, in conformity with South African Statements of Generally Accepted Accounting Practice. The following are the principal accounting policies which are consistent with those of the previous year except for changes in the accounting treatment of tax related charges in the income statement, treatment of assets and liabilities relating to the assurance business and the treatment of trading derivatives on the balance sheet.

5.1 Basis of consolidation

The Group financial statements incorporate the financial results of the Group and its subsidiaries. All subsidiaries in which the Group holds more than one half of the voting rights or over which it exercises control are consolidated from the effect dates of acquisition and up to the effective dates of disposal. In the case of Investec Bank (Israel) Limited, whose accounts are compiled to 31 December annually, the Group projects earnings for the three months to 31 March, after adjusting for any significant events.

In order to reflect the different nature of the shareholders' and policyholders' interests in the long-term assurance business, the assets and liabilities attributable to policyholders are classified separately in the notes to the financial statements.

The effect of all intergroup transactions has been eliminated from the annual financial statements.

The results of operating subsidiaries have been equity accounted in the company.

5.2 Accounting for associates

Group associated companies are accounted for on the equity basis. The consolidated accounts include the attributable share of the results and reserves of associated undertakings, based on audited financial statements for period ending not earlier than three months prior to 31 March. The Group's interests in associated undertakings are included in the consolidated balance sheet in line with the Group's share of net assets. Goodwill arising on the investment in associates is included in goodwill on the balance sheet and is amortised as detailed below.

5.3 Goodwill

Goodwill arising on the acquisition of subsidiaries and associates is written off against income over its useful economic life, normally a period not exceeding 20 years. Negative goodwill arising on acquisitions is included within goodwill and released to profit and loss account in the periods in which the assets are expected to be recovered. Negative goodwill arising on the acquisition of monetary assets is taken to income in the year of acquisition. Any impairments in goodwill are written off immediately.

5.4 Foreign entities

The net assets of foreign subsidiaries, which are classified as foreign entities, are translated at closing rates of exchange and the translation differences arising are taken directly to reserves. The results of these foreign subsidiaries are translated at weighted average rates of exchange for the relevant period. Any exchange differences for foreign currency loans that are used to hedge or fund the net investment in foreign subsidiaries are also taken to reserves.

Goodwill arising on the acquisition of foreign entities is calculated at historical rates.

5.5 Integrated foreign companies

The monetary net assets of foreign operations, that are considered to be an integral part of the operations of the reporting entity, are translated at closing rates of exchange and the translation differences arising are included in income for the period. The results of integral foreign operations are translated at weighted average rates of exchange for the relevant period.

5.6 Foreign currency transactions

Monetary assets and liabilities in foreign currencies are translated at market rates of exchange ruling at the balance sheet date. All foreign currency transactions are translated at the exchange rates ruling at the time of the transaction. Any gain or loss arising from a change in exchange rates subsequent to the date of the transaction is included as a foreign currency gain or loss in the income statement.

5.7 Interest bearing securities

All interest bearing securities are marked to market and gains and losses recognised in the income statement, except for instruments held to maturity. Interest bearing securities held to maturity are carried at amortised cost, net of any impairments.

Securities sold subject to repurchase agreements are recorded as assets. Obligations for the repurchase of these securities are included under deposits and other accounts.

Securities purchased under an agreement to resell the securities at a future date are reflected in the balance sheet as cash and short-term funds.

Stock borrowing and lending transactions that are not cash collateralised are not included in the balance sheet, but are disclosed as assets under administration.

5.8 Derivatives

Derivatives entered into for trading purposes are measured at fair value. Gains and losses arising on the mark to market of trading derivatives are recognised in the income statement in the period in which they arise, whereas income and expenses on hedging instruments are amortised over the life of the instrument, with adjustments made to reflect changes in estimated premiums and discounts. Where the Group has entered into a legally binding netting agreement, related positive and negative fair values of derivatives are offset on the balance sheet. Exposures to market risk are limited through the use of hedging instruments.

The criteria used for a derivative instrument to be classified as a designated hedge include,

- the transaction must effectively reduce the price or interest rate risk of the asset, liability or cash flow to which it is linked; and
- adequate evidence of the intention to link with the underlying risk inherent in the asset, liability or cash flow; and
- must be designated as a hedge at the inception of the derivative contract.

Derivatives designated as hedges are accounted for on the same basis as the underlying assets, liability or cash flow being hedged. Hedging transactions that are superceded, cease to be effective or are terminated prior to the end of the life of the asset, liability or cashflow being hedged are measured at fair value. Any gain or loss arising from re-measurement is deferred and amortised into income or expenses over the remaining life of the item previously hedged. When the underlying asset, liability or cash flow is terminated prior to the hedging transaction, the hedging instrument is re-measured at fair value and the gain or loss is included in the category of income or expense relating to the previously hedged transaction.

5.9 Equity investments

Listed equity investments are stated at market value. Unlisted equity investments are stated at the lower of cost or directors' valuation unless there is a reliable basis to re-measure to fair value.

Profits and losses arising from the revaluation of trading investments are included in income.

The excess of market value of long term investments over cost, determined on a portfolio basis, is taken directly to reserves, whilst any deficit arising is reflected in the income statement. On disposal of such investments, the revaluation is reversed and the full difference between cost and the amount realised is shown in the income statement.

5.10 Other investments

Other investments are valued at market value where a formal market exists or in the case of investments such as insurance policies or equity funds at the value of the underlying investments. Where no formal market exists investments are valued at the lower of cost or directors' valuation.

5.11 Installment credits, leases and rental agreements

Amounts outstanding on these contracts, net of unearned finance charges, are included in advances. Finance charges on instalment sale transactions are credited to income in proportion to the capital balances outstanding. Finance lease income is credited to interest income according to the effective interest method.

5.12 Specific and general provisions for bad and doubtful debts

Specific provisions represent the quantification of actual and expected losses from identified accounts and are deducted from advances in the balance sheet. The amount of specific provision raised is the Group's conservative estimate of the amount needed to reduce the carrying value of the asset to the expected ultimate net realisable value, taking into account the financial status of the customer and any security for the loan. Included in the specific provisions are amounts in respect of interest that is not serviced. The charge for provision for bad and doubtful debts in the income statement includes the unserviced interest that has been transferred to specific provisions.

General provisions augment specific provisions and provide cover for loans which are impaired at the balance sheet date, but which will not be identified as such until some time in the future. The Group's general provision has been determined taking into account the structure and the risk characteristics of the Group's loan portfolio, in accordance with South African banking regulations. General provisions are deducted from advances in the balance sheet.

5.13 Tangible property and equipment

Tangible property (excluding operational properties) and equipment is recorded in the balance sheet at amortised cost less impaired losses. Depreciation is provided on a straight line basis over their useful lives. Leasehold improvements are amortised over the remaining period of the leases. Freehold land, operational properties and investment properties are stated at cost and are not depreciated.

The annual rates used to depreciate assets are as follows:

Computer equipment	33%
Infrastructure	20%
Pool vehicles	20%
Office equipment	20%
Furniture and fittings	10%

5.14 Deferred taxation

Deferred taxation is provided using the liability method on temporary differences between the carrying amount of an asset or liability in the balance sheet and its tax base. Deferred tax assets or liabilities are measured using the tax rates that have been enacted or substantively enacted by the balance sheet date.

Deferred tax assets are recognised to the extent that it is probable that future taxable profit will be available against which the assessed tax losses can be utilised.

5.15 Impairments

At each balance sheet date the Group reviews the carrying value of assets, that are not carried at fair value, for indication of impairment. If the recoverable amount of an asset is less than its carrying amount, the carrying amount of the asset is reduced to its recoverable amount.

Impairment losses are recognised as an expense in the income statement in the period in which they are identified.

5.16 Trust and fiduciary activities

The Group acts as a trustee or in other fiduciary capacities that result in the holding, placing or managing of assets for the account of and at the risks of clients.

As these are not assets of the Group, they are not reflected on the balance sheet, but are included at market value as part of assets under administration.

5.17 Long-term life assurances

The policy liabilities of Investec Assurance Limited comprise unit linked business sold to retirement funds and individual investors. All liabilities are directly related to asset values and no mortality risk is assumed by the company.

The liabilities are valued on a basis consistent with the asset values and comply with the Financial Soundness Valuation basis. Policies are all linked, accordingly, liabilities are taken to be the market value of the units allocated to policyholders.

Investments are reflected at market value. Where market value cannot be determined, investments are reflected at directors' valuation.

Income from long-term assurance business comprises interest, dividends and rental income received on investments held, as well as premium income in respect of linked business sold. Gains and losses arising as a result of the fluctuation in the market value of investments, whether realised or unrealised, are accounted for as movements in the long-term assurance fund which is included in deposits and other accounts in the Group balance sheet.

5.18 Interest received

Interest received is recognised in the income statement as it accrues, based on the effective rates of interest.

Included in interest income is the accrual of unserviced interest that is fully provided for in the charge for bad and doubtful debt in the income statement. Net interest margin is determined after taking into account the bad and doubtful debt charge.

Interest related to intergroup transactions has been eliminated from interest received in the Group results.

In the notes to the annual report, interest received is detailed in terms of the assets generating the income.

5.19 Other income

Other income includes commissions, fees and principal and trading income, net of profit sharing arrangements, which are income based.

Commissions and fees include fees earned from providing advisory services, portfolio management and the arranging of financing for clients. All such commissions and fees are recognised as revenue when the related services are performed.

Principal and trading income consists of investment income and trading income.

Investment income includes realised profits and losses on disposal of investments.

Trading income is shown net of the funding cost of the underlying positions and includes the unrealised profits on trading portfolios that are marked to market daily.

5.20 Retirement benefits

Prior to July 2000, employees had a choice to join either the Group's pension or provident fund. The Group pension fund, governed by the Pension Fund Act (1956), is structured as a money purchase scheme and accordingly can have no funding deficit. The scheme provides that at all times an employee will receive from the fund the amount that has been contributed together with the Group's contribution plus interest and capital appreciation.

Life cover is compulsory for all employees.

For employees joining after July 2000, it is compulsory to join the Group provident fund. The fund is administered by Alexander Forbes Consultants and Actuaries (Tvl) (Pty) Limited and is registered in South Africa.

The Group has no liabilities for other post retirement benefits.

All employer contributions are charged to income, as they become payable in accordance with the rules of the schemes, and included under staff costs.

5.21 Segmental reporting

The Group's segmental reporting is presented in the form of a geographical (primary segment) and business analysis (secondary segment).

The geographical segmental analysis is based on the location of assets.

The business analysis is presented in terms of the Group's four principal businesses and Group Services and Other Activities.

5.22 Comparative figures

Comparative figures are restated where necessary to allow for more meaningful comparison.

PUBLISHED AUDITED RESULTS OF IGL FOR THE YEAR ENDED 31 MARCH 2002

Investec Group Limited

Audited Group Results for the year ended 31 March 2002

- 23rd Year of Uninterrupted Growth
- Headline Earnings \uparrow 28.2%
- Headline Earnings Per Share \uparrow 13.0%
- 10-Year Compound Growth in Headline EPS 28.9%

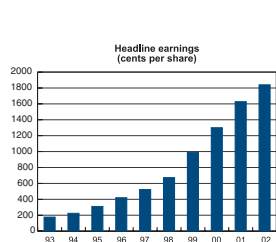

10 year compound growth in headline earnings per share
28.9% per annum

	31 March 2002	31 March 2001*	% Increase/ (decrease)
Headline earnings attributable to ordinary shareholders (R' millions)	1 684	1 314	28.2
Headline earnings per share (cents)	1 840.4	1 628.2	13.0
Dividends declared per share (cents)	825.0	750.0	10.0
Net tangible asset value per share on a fully diluted basis (R)	70.9	63.1	12.4
Capital adequacy ratio (%)	13.2	15.3	(13.7)
Return on average shareholders' funds (%)	27.6	25.8	
Return on average risk weighted assets (%)	3.0	3.0	
Total assets under administration (R' billions)	759	514	47.7
Weighted average number of ordinary shares in issue (millions)	91.5	80.7	

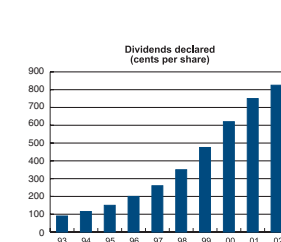

10 year compound growth in dividends per share 28.0% per annum

Consolidated Income Statement

(R' Millions)	31 March 2002	31 March 2001*	% Increase/ (decrease)
Interest received	12 444	12 114	2.7
Interest paid	10 261	10 236	0.2
	2 183	1 878	16.2
Provision for bad and doubtful debts	202	198	2.0
Net interest income	1 981	1 680	17.9
Other income	5 273	3 621	45.6
Commission and fees – recurring	2 990	2 339	27.8
Principal transactions and trading income	1 329	638	108.5
Commission and fees – non-recurring	734	644	14.0
Income from long term assurance business	220	–	–
Total income	7 254	5 301	36.8
Operating expenses	4 885	3 476	40.5
Exceptional items	1 013	312	224.7
Income before taxation	1 356	1 513	(10.4)
Taxation	420	321	30.8
Income after taxation	936	1 192	(21.5)
Share of income/(loss) of associated companies	17	(86)	(119.8)
Operating income	62	70	
Exceptional items	(45)	–	–
Net income	953	1 106	(13.8)
Attributable to minority shareholders	22	13	69.2
Debt interest	931	1 093	
	305	247	23.5
Earnings attributable to ordinary shareholders	626	846	(26.0)
Headline earnings per share (cents)	1 840.4	1 628.2	13.0
Earnings per share (cents)	684.2	1 048.4	(34.7)
Diluted earnings per share (cents)	669.2	1 039.7	(35.6)
Dividend paid per share (cents) – per AC104	815.0	692.5	17.7

Calculation of Headline Earnings

(R' Millions)	31 March 2002	31 March 2001*
Headline earnings	1 684	1 314
Exceptional items	(1 058)	(468)
Goodwill amortised	(747)	(312)
Goodwill impairment	(512)	–
Loss on disposal of subsidiaries and fixed assets	(21)	–
Profit on disposal of non-trading loans	267	–
Share of associates' exceptional items	(45)	(156)
Attributable earnings	626	846

Statement of Changes in Shareholders' Equity

(R' Millions)	31 March 2002	31 March 2001*
Balance at beginning of year	9 028	7 912
– as previously reported	–	7 604
– prior year adjustment – dividends	–	308
Net issue of shares and debentures	4 339	697
Own shares acquired	(1 584)	(27)
Issue of convertible preference shares	–	385
Earnings attributable to ordinary shareholders	626	846
Dividends paid	(791)	(558)
Movement in foreign currency translation	1 612	152
Movement in investment revaluation reserve	–	(379)
	13 230	9 028

Abridged Cash Flow Statement

(R' Millions)	31 March 2002	31 March 2001*
Cash retained/(utilised) from operating activities	26 053	(6 857)
Cash utilised in investing activities	(1 649)	(1 423)
Cash (outflows)/inflows from financing activities	(395)	2 974
Net increase/(decrease) in cash and short-term funds	24 009	(5 306)
Cash and short term funds at beginning of year	69 176	73 118
Effect of exchange rates on opening balance of cash and short term funds	18 039	1 364
Cash and short term funds at end of year	111 224	69 176

Consolidated Balance Sheet

(R' Millions)	31 March 2002	31 March 2001*
Assets		
Cash and short term funds	111 224	69 176
Short term negotiable securities	64 738	53 874
Investment and trading securities	17 917	9 968
Other assets	9 020	6 237
Advances	54 413	38 062
Associated companies	503	544
Fixed assets	2 499	1 320
Goodwill	5 485	2 849
Long-term assurance assets attributable to policyholders	38 042	12 702
	303 841	194 732
Equity and liabilities		
Capital and reserves		
Ordinary share capital	58	49
Compulsorily convertible debentures	2 317	2 321
Convertible preference shares	385	385
Reserves	10 470	6 273
	13 230	9 028
Interest of minority shareholders in subsidiaries	541	267
Total shareholders' funds	13 771	9 295
Subordinated debt	2 245	1 945
Total capital resources	16 016	11 240
Liabilities		
Deposits and other accounts	249 270	170 292
Taxation	513	498
Long term assurance liabilities attributable to policyholders	38 042	12 702
	303 841	194 732
Acceptances, guarantees and letters of credit	13 226	11 368

*Restated for changes to accounting policies and disclosures

Geographic and business analysis of headline net income before tax** – 31 March 2002

(R' Millions)	Southern Africa & Other	United Kingdom & Europe	Israel	United States of America	Investec Group Limited
Investment Banking	282	296	52	(46)	584
Treasury and Specialised Finance	568	153	4	–	725
Asset Management and Assurance Activities	467	29	4	–	500
– Asset Management	247	29	4	–	280
– Assurance Activities	220	–	–	–	220
Private Client Activities	134	370	46	19	569
Other	(118)	67	(1)	43	(9)
Headline net income before tax	1 333	915	105	16	2 369

**Headline net income before tax represents income before taxation prior to exceptional items relating to income before taxation.

Geographic and business analysis of headline net income before tax** – 31 March 2001

(R' Millions)	Southern Africa & Other	United Kingdom & Europe	Israel	United States of America	Investec Group Limited
Investment Banking	172	432	29	–	633
Treasury and Specialised Finance	468	121	2	–	591
Asset Management and Assurance Activities	194	32	2	–	228
– Asset Management	194	32	2	–	228
– Assurance Activities	–	–	–	–	–
Private Client Activities	100	235	32	33	400
Other	(230)	145	–	58	(27)
Headline net income before tax	704	965	65	91	1 825

This report has been prepared in compliance with South African Statements of Generally Accepted Accounting Practice. Accounting policies are consistent with those of the previous year.

Investec Group Limited
("Investec")
Registration number: 1925/002833/066
JSE Code: INT ISIN: ZA6509012555

Investec
Group Limited

Commentary

Overall performance

In a year characterised by profound external events contributing to heightened market volatility as well as challenging internal operations, Investec is satisfied to announce that headline earnings per share for the year ended 31 March 2002 increased by 13% to R140.4c. The Group's geographic spread and diverse business portfolios and the inclusion of strategic and financial services businesses acquired from Fedure Holdings ("the Fedure acquisition") for the ten months in the period enabled it to achieve growth in its headline earnings of 28.2% to R1 684 million, despite the challenging period experienced by most investment banks worldwide.

Financial highlights of the period include:

- Growth in income before tax and exceptional items ("headline NIBT") of R2 369 million was underpinned by an increase of 45.6% in non-interest income, raising the percentage of total income from 65.8% to 70.7%.
- Return on average tangible shareholders' funds increased from 25.8% (restated) to 27.6%, with growth in tangible net assets of 25.3% to R7 745 million. More importantly the Group's return on investment remained constant at 17.2% during a period in which shareholders' funds increased following the issue of equity to finance the Fedure acquisition.
- Annual income as a percentage of total income decreased from 41.1% to 37.8% due to a significant increase in income from principal transactions and trading activities. Strong contributions from the newly acquired commodities trading team, the United Kingdom ("UK") and South African ("SA") private equity activities and the SA property division together with the inclusion of the traded endowment business from the Fedure acquisition for the first time were largely responsible for this increase. Notwithstanding the decrease in annual income, the percentage remains high for a specialist banking group like Investec demonstrating the stability of the Group's earnings base.
- An increase in total dividends per share of 10% over the prior period to 825 cents, representing a 10-year compound annual growth rate of 28.0% and retaining the Group's dividend cover of 2.2.

The past twelve months represented the achievement of a significant milestone in the history of Investec with the receipt of permission to dual-list the Group on the London Stock Exchange. This initiative is considered a key step in the Group's established internationalisation strategy with benefits expected to be derived from raising Investec's international profile and recognition as an international financial group.

The Group faced a number of challenges during the period. Considerable negative sentiment was expressed with respect to the Fedure acquisition and the settlement of outstanding claims between the contracting parties. Furthermore, the impact of the 9/11 terrorist attacks in the UK created uncertainty in the market about Investec's future strategic endeavours. On a macro level, the SA banking sector endured an extremely difficult period, prompting a number of consolidations amongst its participants and more recently the Fedure acquisition for the first time was largely responsible for this increase. Notwithstanding the decrease in annual income, the percentage remains high for a specialist banking group like Investec demonstrating the stability of the Group's earnings base.

Group Operating Review

Investment Banking

Investment Banking headline NIBT decreased by 7.7%, reflecting the difficult market conditions across all geographies in which the division operates. As a result, the division's contribution to Group headline NIBT (excluding "other" activities) dropped from 34.2% last year to 24.6% in the current year. Investment Banking in SA performed well with headline NIBT increasing by 44.2% during the period under review. The sluggish capital raising market resulted in Investec Corporate Finance ("ICF") focusing primarily on mergers and acquisition ("M&A") activity, conducting 39 transactions with a combined value of approximately R2.4 billion during the reporting period. ICF has established itself as one of SA's leading domestic corporate finance houses and was ranked by the most recent Ernst & Young survey as having achieved the highest volume and value of transactions undertaken during the 2001 calendar year. Furthermore, the private equity division continued to make select investments and realisations resulting in the division posting results above expectations.

The period under review proved difficult for Investec Henderson Crowdwate in the UK (rebranded Investec Investment Banking and Securities ("IBS")) which reported headline NIBT down 49.1% on the previous year in which it had significant losses. The division sought to offset the decline in revenues, resulting from the severe drop in capital market transactions, by raising its profile in domestic financial advisory work, particularly in respect of M&A activities. For the year ended 31 March 2002, the division advised on 21 M&A transactions with a combined value of approximately £800 million. IBS received number one rankings for its research in the leisure, beverages, telecommunications and media sectors, as well as top three rankings in three other sectors in the Reuters 2001 small-cap survey.

PMG Capital (since renamed Invesco Inc.) in the US, which was acquired in July 2001, posted operating losses of R46 million. The operation's merchant banking, technology sector focused, micro-cap model was particularly vulnerable to the weak operating environment during the financial year. The Group sought to strengthen investment banking operations following the recruitment of two teams in its chosen niches of TMT and healthcare.

Investec Wentworth generated creditable results in its first year of operation under the Investec banner. The Group strengthened its investment banking capability in the Australian market through the acquisition of Melbourne-based Chronwork in February 2002 and the establishment of a private equity capability.

Treasury and Specialised Finance

The Treasury and Specialised Finance division experienced another year of solid growth contributing 35.5% to the Group's overall headline NIBT (excluding "other" activities), with a growth of 22.7%. The division's banking activities performed particularly well, with strong contributions from the treasury financial products, structured finance and project and resource finance units. The financial markets activities proved mixed performances with losses incurred on the interest rate desk slightly offsetting the strong results from the commodities unit.

The division continued to enhance, expand and integrate its international capabilities. During the period under review an equities derivatives operation and forex trading desk were established in New York. In the third quarter of 2001, Investec launched its equities derivatives business in the UK. The project and resource finance unit expanded its product range to include project and specialist advisory services and initiated expansion into the UK. Furthermore, the structured finance unit extended its capabilities in the UK and Australia.

The acquisition of the European Capital team in November 2001 substantially enhanced the project finance and advisory platform in the UK and Europe. In SA, the project finance team successfully closed the NI-NA Platinum Toll Road project, the largest project of its type in SA to date. Furthermore, the team arranged and placed R1 billion of CP-linked bonds in the SA capital market to finance this project.

The financial products division performed well, with notable contributions from the financial engineering team which advised on a number of structured credit transactions.

Particularly strong performance was experienced by the commodities team in its first year of operation. Substantial progress was made in creating an internal infrastructure establishing new and leveraging off existing Investec customers. The division actively traded with a number of corporate clients across the base metals and bullion markets.

Private Client Activities

Private Client Activities posted strong results, particularly as a result of solid performances from the Group's UK and SA private banking operations, with headline NIBT increasing by 42.3%, comprising 23.6% of the Group's total versus 21.6% last year. Of the total headline NIBT generated by the division, the private banking business contributed 62% and private client stockbroking and portfolio management businesses contributed 38%.

Private Banking

The private banking operations in the UK and SA benefited from the lower interest rate environment enjoyed for most of the period under review. The Group was able to grow its global lending book from R20.2 billion to the previous year to R28.1 billion, an increase of 39.1%.

The performance from the Southern African private banking operation was largely driven by strong growth in advances, assets under administration and non-interest income. The private bank received a number of accolades, including the PricewaterhouseCoopers' peer rating as the number one private bank in Southern Africa for the second consecutive year.

Investec Private Bank in the UK posted creditable results with particularly strong growth from the trust and fiduciary businesses which now operate under the name of Investec Trust Group. In addition, the division expanded its investment advisory offering and launched a number of new multi-currency products into the UK market.

Private Client Stockbroking and Portfolio Management

Investec's Private Client Stockbroking and Portfolio Management division was negatively affected by the lower market indices and reduced market volumes. As at 31 March 2002, the division had R157 billion assets under administration.

In January 2002, Investec Securities in South Africa purchased Merrill Lynch SA's private client division in Cape Town which added R4 billion in assets under management and further enhanced the division's capabilities.

Carr Sheppards Crowdwate ("CSC") in the UK, despite low market volumes, managed to generate net new funds under management of £595 million although total funds under management declined marginally to £6.1 billion. In 2001, the division's capabilities were extended through the recruitment of most of the international team of the Gerrard Group which provides an international portfolio management service to existing and prospective clients. Another growth area has been the successful targeting of the small- to medium-sized charities sector where CSC now manages £850 million for over 400 charities.

In the US, the private client group was particularly affected by the poor market conditions. In consideration of the minimal prospects for growth of this asset as well as the strategic fit with the Group, in March 2002 Investec management decided to exit the retail brokerage business with a management buy-out of the business presenting the most likely alternative.

Contribution analysis - % of Net Income Before Tax (excluding "other" activities)

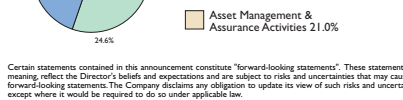

Asset Management and Assurance Activities

Asset Management

The Group's Asset Management activities delivered a period of strong headline NIBT growth of 22.8% to R280 million, successfully leveraging off its stable SA platform and utilising synergies from the acquisition of the Fedure Asset Management business. Similarly, assets under management have grown 53% from R172 billion to R263 billion, influenced by the depreciation of the Rand.

The key achievements of the past year include strong investment performance in SA, the successful absorption of the asset management business forming part of the Fedure acquisition; the retention of its client base in extremely volatile markets and the further development of the business' international growth platform.

The core SA institutional business had a strong recovery in terms of both performance and new business production. Investec Asset Management achieved second position over the critical one year and five year periods in the Alexander Forbes South African Large Manger Watch. During the period under review, the SA personal investments division of Investec Asset Management successfully restated Fedure Unit Trusts and TMA to form the second largest unit trust and portfolio complex in the SA market. The good performance of the division's unit trusts over the reporting period earned it, on average, top quartile rankings in its in-house managed funds. Investec also achieved third place overall in the most recent Plexus survey which assesses three-year investment performance.

In spite of weakening industry conditions, the Investec Asset Management UK unit trust business produced more than R2.5 billion of net inflows during the past twelve months with its offshore funds, listed in Guernsey and Dublin, also receiving net inflows in excess of R43 billion. This can be attributed to a well-coordinated effort from the Group's retail businesses.

On the institutional front, Investec Asset Management continues to win fixed income mandates in the UK with specific success in the public sector market. Future focus will be entering the UK pensions market in a meaningful manner, supplying both specialist equity and fixed income services.

Assurance Activities

Having concluded and implemented a reinsurance contract for the individual life book with Capital Alliance Holding ("CAL"), focus was directed towards addressing the numerous problems inherent in the remainder of the assurance business acquired as part of the Fedure acquisition comprising group benefits and a select element of individual life activities.

Most critical was the restructuring of the smoothed bonus portfolios, where losses in the prior period resulted in the well-publicised removal of a portion of non-vested bonuses attached to these policies. The restructuring exercise was completed by December 2001 and is expected to ultimately contribute towards the future protection of policyholder portfolios and the mitigation of shareholder risks arising from volatile financial markets.

Marked inroads were achieved from an operational perspective in that significant cost reductions were realised with the decrease in the workforce to 560 employees from 760 on acquisition; enhancement to systems facilitating more efficient valuation exercises; and significant improvements in the compliance and management aspects of the business with the appointment of an independent statutory auditor and the assignment of qualified executive management.

As at 31 March 2002, the embedded value of Investec Employee Benefits was R2 951 million, improved by R306 million since 30 September 2001 largely due to reduced costs and the benefits of increased matching of assets and liabilities factored into the calculation. As a further consequence, the statutory capital adequacy requirement ("CAR") dropped to R866 million, increasing the CAR cover from 2.47 to 2.73.

Future attention will be devoted to improving efficiencies and the level of service offered to clients.

Other activities

The negative contribution by the Group's "Other Activities" of R9 million represents different business and activities whose profitability is offset by the costs incurred in providing certain services to the Group, thereby ensuring that key functions are effectively integrated and standardised across the Group. Moreover, the costs associated with the centralised funding of the Group's operations, are included in this category.

Highlights of the "Other Activities" performance include a strong contribution from the SA property division which has, over the course of the year, been actively involved in a number of property-related corporate finance transactions, asset management mandates (including the Fedure Life property portfolio) and realisation of select portfolios. Inclusion of the UK traded endowment business for the first time during 2002 following the Fedure acquisition assisted in compensating the reduced profitability generated from the Group's UK clearing and execution and international trade finance activities, both of which struggled in unfavourable operating conditions.

The final component, the return on surplus capital, posted earnings of R317 million, albeit that it was 10.5% down on the prior period. Interest rate movements coupled with the reduction in funding of central costs and other Group-wide initiatives contributed towards this decline in earnings.

Headline attributable earnings by geography

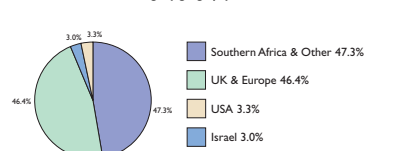

Geographic Performance

From a regional perspective, an analysis of headline earnings by geography between the 2001 and 2002 financial years reveals a notable shift from the UK and Europe to Southern African operations, with the latter increasing its contribution from 30.7% in 2001 to 47.3% in the current year and a concomitant drop in the comparative UK percentage from 62.8% to 46.4%.

This trend is explained as follows:

- The majority of businesses acquired as part of the Fedure acquisition were SA-based, thereby contributing to enhanced earnings growth in the region due to its inclusion for 10 months in the period under review;
- All round strong performances from the SA operations, with a notable contribution from its investment banking, private banking, treasury and specialised finance and private activities;
- First year of positive contribution amounting to R15 million from the Group's Australian operations, which is included in Southern African and Other regions; and
- The fact that the UK investment banking business enjoyed a year of exceptional performance in 2001. The equity market buoyancy in the first half of that year served to establish a high base from which to grow. This latter point contributed towards the drop in real earnings of the UK businesses which was partially abated by the steep devaluation of the rand, amounting to 27.5% on average, over the relevant period.

Of its remaining worldwide operations, the Group's Israeli business ended the year on a stronger note, generating growth in real terms of some 30.6% off a low base in 2001. The United States ("US") operations continued to suffer from prolonged equity investment scepticism with the dramatic slowdown of transactional and market activity resulting in overall negative growth, aggravated by the losses of R46 million attributable to the new investment banking trading investment banking including private equity activities, which was introduced for the first time in 2002.

Australia, on the other hand, remained relatively insulated from global conditions, as falling interest rates and a weak Australian dollar in the second six months coupled with high property prices boosted economic growth.

Notwithstanding the above, the concentration of assets and net tangible shareholders' funds is weighted towards the Group's international activities, with 63% and 66% respectively residing offshore.

Assets by geography

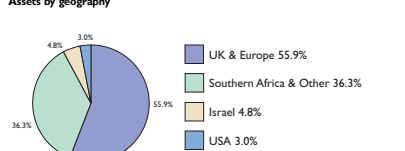

Financial Statements Analysis

Income

Total income grew by 36.8% to R7 254 million, of which 70.7% comprised other (non-interest) income which increased by 45.6% to R5 132 million. Factors contributing towards this strong growth include an increase of 27.8% in recurring fees and commissions added by the acquisition of Fedure's financial services operations; the inclusion of income from life assurance business for the first time in 2002; and most notably the doubling of income derived from principal transactions and trading income. As indicated in the financial highlights section of this report, commodities and foreign exchange trading investment banking including private equity activities in both SA and UK and the SA property division performed particularly well during the year. Furthermore, the UK traded endowment business, which was part of the Fedure acquisition was included in earnings for the first time in 2002, contributing R139 million to trading income.

Net interest income increased by 17.9% to R1 981 million as a consequence of healthy organic growth in advances of 20.8%, net of exchange rate devaluations, fuelled predominantly by increased private banking activity worldwide and stable growth in the SA corporate loan book.

Notwithstanding this growth, the Group witnessed an improvement in the quality of its advances, as depicted by the continuing declining trend in the percentage of gross non-performing loans to advances from 1.65% last year to 1.12%, thereby facilitating a drop in the income statement provision from 0.54% to 0.43% of average advances in the current year. Total provision coverage remains high by SA industry norms both on a gross and net basis with the relevant percentages being 168.3 and 244.0 respectively.

Also included in net interest income is an amount of R88 million representing the translation gain attributable to the Group's only integrated operation. Restricted assets which conducts international trade finance activities in Europe, the US and Mauritius. All other gains generated by the rand's significant decline over the period are included in the foreign currency translation reserve which increases by R1 612 million in 2002. This reserve enhances total shareholders' funds and essentially represents the benefit of the Group's international diversification undertaken over the past ten years.

Cost Control

Despite a sharp increase of 40.5% of operating expenses to R4 885 million, an analysis of the movement reveals that 37.0% of this growth was attributable to acquisitions which conduct international trade finance activities in Europe, the US and Mauritius. All other gains generated by the rand's significant decline over the period are included in the foreign currency translation reserve which increases by R1 612 million in 2002. This reserve enhances total shareholders' funds and essentially represents the benefit of the Group's international diversification undertaken over the past ten years.

Having regard to this, the overall ratio of operating expenses to total income increased from 63.2% to 65.5%. This mainly reflects the reduced revenues generated from the Group's UK investment banking activities as well as capacity building in some of the recent offshore acquisitions. However, the inclusion of ten months' income from the Fedure acquisition helped to cushion this ratio to some extent due to synergistic gains producing higher income growth compared to expenses.

Taxation

The effective tax rate for the Group remained constant at 20.4%, reflecting the continued utilisation of assessed losses in the UK and the negative tax charges resulting from operational and provisional losses in the US due to the pending disposal of its private client activities. These decreases were offset by an increase in the SA effective tax rate from 26.5% to 28.6% in the current year.

Income from Associates

Investec underwent a rights issue undertaken by CAL in October 2001, increasing the Group's effective interest in CAL to 29.7%, making it an associate in terms of IAS 11. Based on publicly available information, an amount of R49 million has been accrued representing Investec's share in its operating earnings for the five and a half months ended 31 March 2002.

Recognising that the effective date of the Fedure acquisition was 1 June 2001, treatment of Fedure's earnings as income from an associate was deemed to be appropriate for the first two months of Investec's financial year. The net impact on Investec's earnings was a loss of R32 million, comprising operating profits of R13 million and exceptional losses of R45 million.

Exceptional Items

The significant increase in exceptional items from R468 million in 2001 to R1 058 million in 2002 is as a result of a number of factors listed below:

- Investec's share of associates' exceptional items as detailed in the previous paragraph.
- Increased goodwill amortisation relating to acquisitions made during the current year and towards the end of the previous year, of which the largest contributor was the Fedure acquisition.
- Losses of R80 million in respect of the pending disposal of the US private client operations, of which R40 million represents the impairment of unamortised goodwill attributable to those particular businesses.
- An impairment of R472 million in relation to the purchased goodwill on Fedure's insurance business, reflecting the problems in that business which were not apparent at the time of acquisition. The impairment test was performed in terms of the requirements of both IAS 38 and IAS 13, applying a combination of value in use and net selling price on all components of the Fedure acquisition.

Offsetting these exceptional losses was the recognition of profits on the disposal of the UK insurance business, as well as the realisation of a fixed income long term loan asset which formed part of the Group's non-trading portfolio. Low interest rates which prevailed for the majority of the year provided the opportunity for the Group to realise this investment to its best advantage.

Capital Resources

Total capital resources increased by 42.5% to R16 016 million since March 2001. This was attributable to a net increase of R2 755 million in shares and debt issuance following the Fedure acquisition; the substantial movement in the foreign currency translation reserve detailed elsewhere in this report; and the issue of an additional R300 million of subordinated debt in the SA market. As a consequence, the Group's capital adequacy ratio remains high at 13.2% against a growth in risk weighted assets of 32.9% during the financial year. Tier one capital of R12 109 million represents 66.0% of the total net qualifying capital attributable to banking activities, which is well in excess of the statutory minimum of 50%.

Viewed in conjunction with headline earnings, the return on average shareholders' funds over the period increased from 25.8% to 27.6%, with the net tangible asset value per share increasing by 12.5% from 6 311.5 cents to 7 097 cents.

Tangible net asset value by geography

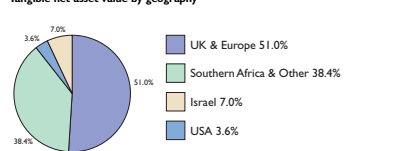

Total Assets Under Management

On balance sheet assets recorded strong growth of 56.0% from March 2001, influenced by the inclusion of the Fedure assets and its resulting goodwill; organic growth in advances; and the impact of the gain realised by the devaluation of the rand against the world's major currencies.

Third party assets under management increased by 42.2% to R4550 billion, positively affected by recent acquisitions within the institutional, retail, property and, to a lesser extent, private client stockbroking activities.

Prospects

Despite the possibility of subdued market conditions continuing into the next financial period with its obvious repercussions to the organisation's performance, the Group has overcome a major hurdle in dealing with the complexities surrounding the Fedure acquisition and completed the integration of aligned businesses.

By perpetuating its specialised and focused approach through the construction of well-defined, value-added businesses and concentrating on select market niches in which it can compete effectively, the Group looks forward to a year in which it can focus all its efforts on its core strategy of building one of the world's leading specialist banking groups.

On behalf of the board

H S Herman, Chairman, S Koseff, Chief Executive, B Kantor, Managing Director

Dividends

Note on Dividend Declaration

In line with the requirements of the revised accounting statement, Events After the Balance Sheet Date (IAS 107) in terms of which dividends to holders of equity instruments that are proposed or declared after the balance sheet are not recognised as a liability at the balance sheet date, the total value of this dividend has not been recognised in the current reporting period. Consequently, reserves at 31 March 2002 have increased to the extent of R416.7 million, with opening reserves restated accordingly giving rise to an increase of R356 million.

Dividend Announcement

A final dividend (No. 94) of 450 cents (2001 - 440.0 cents) per ordinary share has been declared in respect of the year ended 31 March 2002.

The last day to trade cum dividend will be Friday 7 June 2002. The shares will commence trading ex dividend on Monday 10 June 2002. The record date will be Friday 14 June 2002. Payment will be made on Tuesday 18 June 2002.

Share certificates may not be dematerialised or rematerialised between Monday 3 June and Friday 14 June 2002, both dates inclusive.

By order of the board

S Nook, Secretary

Registered office: 100 Grayston Drive, Sandown, Senften 2196.

Transfer secretaries: Computershare Investor Services Limited, 8th Floor, 11 Diagonal Street, Johannesburg 2001.

Directors: H S Herman (Chairman), S Koseff (Chief Executive), B Kantor (Managing Director), S E Abrahams, Dr H K Dames, G H Davis, D E Jewell, I R Kantor, D M Lawrence, D R M Potsepp, Dr M Z Nkomo, B Tlapani, P R S Thomas.

Investec Group Limited ("Investec") (Registration number 1925/002833/06)

JSE Code: INT ISM Code: ZAE000012555



PRO FORMA FINANCIAL INFORMATION RELATING TO IGL AND INVESTEC PLC

Set out below, for illustrative purposes only, is the pro forma financial information relating to IGL and Investec PLC subsequent to the IGL reorganisation, the IGL internal restructure, the IGL capital restructure, the IGL unbundling and the implementation of the DLC Structure.

I. BALANCE SHEETS

R'million At 31 March 2002	Before	IGL reorganisation Adjustments		After the IGL reorgan- isation	After the IGL unbundling and the implementation of the DLC Structure	Pro forma Investec PLC	
		1	2	Pro forma IGL	Pro forma DLC	Pro forma IGL	
ASSETS							
Cash and short term funds	111 224	(35)		111 189	111 189	13 168	98 021
Short term negotiable securities	64 738			64 738	64 738	4 636	60 102
Investment and trading securities	17 917			17 917	17 917	11 260	6 657
Other assets	9 020			9 020	9 020	9 390	(370)
Advances	54 413			54 413	55 306	30 676	24 630
Associated companies	503			503	503	468	35
Fixed assets	2 499			2 499	2 499	1 721	778
Goodwill	5 485			5 485	5 485	3 026	2 459
Long-term assurance assets attributable to policyholders	38 042			38 042	38 042	38 042	–
	303 841	(35)	–	303 806	304 699	112 387	192 312
EQUITY AND LIABILITIES							
Capital and reserves							
Ordinary share capital, share premium and reserves	10 528	425	1 656	12 609	13 502	5 386	8 116
Compulsorily convertible debentures	2 317		(1 656)	661	661	661	–
Convertible preference shares	385	(385)		–	–	–	–
	13 230	40	–	13 270	14 163	6 047	8 116
Interest of minority shareholders in subsidiaries	541			541	541	285	256
Total shareholders' funds	13 771	40	–	13 811	14 704	6 332	8 372
Subordinated debt	2 245			2 245	2 245	2 245	–
Total capital resources	16 016	40	–	16 056	16 949	8 577	8 372
Liabilities							
Deposits and other accounts	249 270	(75)		249 195	249 195	65 492	183 703
Taxation	513			513	513	276	237
Long term assurance liabilities attributable to policyholders	38 042			38 042	38 042	38 042	–
	303 841	(35)	–	303 806	304 699	112 387	192 312
Number of IGL ordinary shares in issue	92 281 158 ³	2 000 000	9 500 000	103 781 158	109 032 774	38 399 028	70 633 746
Net tangible asset value per share	70,92			71,29			

Adjustments:

The adjustments in terms of the IGL reorganisation as detailed in paragraph 4.2 of this circular, are as follows:

- 2 000 000 IGL convertible preference shares have been converted into 2 000 000 IGL ordinary shares. A penalty of R35 million, to compensate for the present value of the lower dividend which Inhold will receive

in terms of this early conversion and in accordance with the terms of the IGL convertible preference shares, has been paid for this early conversion. Deposits and other accounts have been reduced by R75 million, being the liability portion of the IGL convertible preference shares in terms of accounting statement, AC125. R29 million of the R35 million penalty relates to the equity portion of the IGL convertible preference shares and has been charged directly to share premium. The balance of R6 million has been expensed as an exceptional item.

2. In terms of the continuing obligations under Fintique III further details of which are included in paragraph 2 of Annexure XV to this circular; 9 500 000 compulsorily convertible debentures have been acquired for the consideration of 9 500 000 IGL ordinary shares.
3. At 31 March 2002 there were 96 193 177 IGL ordinary shares in issue. The number of shares in issue at 31 March 2002 has been adjusted for changes in the number of IGL ordinary shares in issue subsequent to 31 March 2002, but prior to the date of issue of this circular and prior to the IGL reorganisation. The difference of 3 912 019 IGL ordinary shares relates to the share buy-backs by IGL between 1 April 2002 and 31 May 2002, primarily the cancellation of the IGL ordinary shares bought back from wholly-owned subsidiaries of IGL as a result of the specific share buy-back of the IGL ordinary shares unbundled by Fedsure Holdings Limited.
4. 70 633 746 Investec PLC ordinary shares are issued to IGL by Investec PLC in terms of the IGL internal restructure. Subsequent to the IGL internal structure, but before the IGL unbundling, 5 251 616 Investec PLC ordinary shares will be transferred to the IGL share scheme as set out in paragraph 4.3 of this circular. The balance of 65 382 130 Investec PLC ordinary shares held by IGL will be unbundled to IGL members in terms of the IGL unbundling.

Assumptions:

1. The IGL reorganisation, the IGL internal restructure, the IGL capital restructure and the IGL unbundling were implemented on 31 March 2002.
2. An exchange rate of R16,1577251: £1 has been used, being the closing R:£ exchange rate on 31 March 2002.
3. The number of Investec PLC ordinary shares in issue is prior to the proposed Investec PLC capital raising as referred to in paragraph 4.9.3 of this circular.
4. The pro forma balance sheets relating to IGL and Investec PLC after the implementation of the IGL unbundling and the DLC Structure have been determined based on the respective assets and liabilities of the PLC operations at 31 March 2002, with the balance of the assets and liabilities of the existing operations at 31 March 2002 being retained by IGL.
5. No account has been taken of costs associated with the transactions.

2. INCOME STATEMENT

R'million for the year ended 31 March 2002	Before As published	IGL	After the	After the IGL unbundling	
		reorganisation adjustments	IGL reorganisation	and the implementation of the DLC Structure	
			Pro forma IGL	Pro forma IGL	Pro forma Investec PLC
Interest received	12 444		12 444	3 450	8 994
Interest paid	10 261		10 261	2 410	7 851
	2 183		2 183	1 040	1 143
Provision for bad and doubtful debts	202		202	226	(24)
Other income	5 273		5 273	1 937	3 336
Total income	7 254		7 254	2 751	4 503
Operating expenses	4 885		4 885	1 433	3 452
Exceptional items	1 013	6	1 019	601	418
Income before taxation	1 356	6	1 350	717	633
Taxation	420		420	297	123
Net income after taxation	936	6	930	420	510
Share of income/(loss) of associated companies	17		17	16	1
Net income	953	6	947	436	511
Attributable to minority shareholders	22		22	0	22
	931	6	925	436	489
Debenture interest	305		305	305	0
Earnings attributable to ordinary shareholders	626	6	620	131	489
Weighted average number of ordinary shares in issue (millions)	91,5	2,0	93,5		
Earnings per share (cents)	684,2		663,1		
Headline earnings per share (cents)	1 840,4		1 801,1		

Adjustments:

- 2 000 000 IGL convertible preference shares have been converted into 2 000 000 IGL ordinary shares. A penalty of R35 million, to compensate for the present value of the lower dividend which Inhold will receive in terms of this early conversion and in accordance with the terms of the IGL convertible preference shares, has been paid for this early conversion, as set out in paragraph 4.2 of this circular. R29 million of the R35 million penalty relates to the equity portion of these preference shares and been charged directly to share premium. The balance of R6 million has been expensed as an exceptional item.

Assumptions:

- The IGL reorganisation, the IGL internal restructure and the IGL unbundling were implemented with effect from 1 April 2001
- The pro forma columns after the IGL unbundling and the implementation of the DLC Structure for IGL and Investec PLC are based on the segmental results of operations for the year ended 31 March 2002 adjusted for the following:
 - the pro forma effects of the IGL reorganisation; and
 - the pro forma results of IGL exclude the Australian operations and the pro forma results of Investec PLC include the results of the Australian operations as these operations will be transferred to Investec PLC in terms of the IGL internal restructure.
- Fintique III has waived its right to dividends on the 9 500 000 IGL ordinary shares issued for the acquisition of the 9 500 000 compulsorily convertible debentures. Accordingly, these IGL ordinary shares are not included in the weighted average number of IGL ordinary shares, in terms of accounting statement, AC104.
- No account has been taken of any costs associated with the transactions.

Note:

On implementation of the PLC structure, an ordinary share held in either Investec PLC or IGL will give the holder the same effective economic interest in Investec, including the same rights to dividends, capital and voting in respect of joint electorate matters. Accordingly, the earnings and headline earnings which are relevant to an IGL member and an Investec PLC shareholder are those of the Group as reflected in the "Pro forma IGL after the reorganisation column and not those relating to IGL and Investec PLC individually.

REPORTING ACCOUNTANTS' REPORT ON THE PRO FORMA FINANCIAL INFORMATION RELATING TO IGL AND INVESTEC PLC

"The Directors
Investec Group Limited
PO Box 785700
Sandton
2146

14 June 2002

Ladies and Gentlemen

INDEPENDENT REPORTING ACCOUNTANTS' REPORT IN RESPECT OF THE UNAUDITED PRO FORMA FINANCIAL INFORMATION ("pro forma financial information") RELATING TO INVESTEC GROUP LIMITED ("IGL") AND INVESTEC PLC ("Investec PLC") ("the IGL and Investec PLC pro forma financial information")

Introduction

We report on the pro forma financial information in respect of IGL and Investec PLC as set out in Annexure VIII of the circular of which this report forms part, after the implementation of the transactions ("the transactions") (as defined in the circular to IGL members and Investec Holdings Limited members of which this report forms part ("the circular")). The IGL and Investec PLC pro forma financial information has been prepared for illustrative purposes only and only to provide information about how the transactions might have impacted on IGL's financial information presented.

At your request and for the purposes of compliance with the Listings Requirements of the JSE Securities Exchange South Africa, relating to the above, we present our report on the IGL and Investec PLC pro forma financial information.

Responsibilities

The compilation, contents and presentation of the circular are the responsibility of the directors of IGL. Our responsibility is to form an opinion on the pro forma financial information as set out in Annexure VIII of the circular.

We do not accept responsibility for any reports previously given by us on any financial information used in the compilation of the IGL and Investec PLC pro forma financial information included in the said circular; beyond that owed to those to whom those reports were addressed by us at the dates of their issue.

Basis of opinion

Our work, which did not involve any independent examination of any of the underlying financial information, consisted primarily of agreeing the IGL and Investec PLC pro forma financial information presented with the published audited financial position and financial results of IGL, considering evidence supporting the adjustments to that information and discussing the IGL and Investec PLC pro forma financial information and effects with the directors of IGL.

Because the above procedures do not constitute either an audit or a review made in accordance with South African Auditing Standards, other matters might have come to our attention that would have been reported to you.

Opinion

In our opinion:

- the IGL and Investec PLC pro forma financial information has been properly compiled on the basis stated;
- such basis is consistent with the accounting policies of IGL; and
- the adjustments are appropriate for the purpose of the IGL and Investec PLC pro forma financial information as disclosed and in terms of the transactions as defined in the circular.

We consent to the inclusion of this report in the circular to IGL members to be issued on or about 20 June 2002 in the form and context in which it appears therein and we confirm that we have not withdrawn that consent prior to the issue of the said circular.

Yours faithfully

Ernst & Young''

TRADING HISTORY OF INHOLD ORDINARY SHARES ON THE JSE

The highest and lowest prices as well as the volumes at which Inhold ordinary shares traded on the JSE for the second, third and fourth quarters of 1999, for each quarter of 2000, for the first quarter of 2001, for each month from April 2001 to April 2002 and for each trading day from 2 May 2002 to 31 May 2002, are set out below:

	High (cents)	Low (cents)	Volume
QUARTER ENDED			
1999			
30 June	23 000	19 500	1 441 730
30 September	22 700	16 320	1 156 345
31 December	24 000	16 900	1 756 684
2000			
31 March	26 000	21 500	979 508
30 June	22 880	18 500	2 540 155
30 September	21 500	19 000	1 663 531
31 December	22 700	18 480	3 254 780
2001			
31 March	24 000	17 100	1 448 733
MONTH ENDED			
April	19 400	15 700	580 551
May	20 500	17 380	667 442
June	21 000	18 300	1 297 789
July	21 000	17 240	878 447
August	17 860	15 900	945 805
September	17 400	13 200	5 484 180
October	14 500	12 600	587 932
November	15 520	12 200	596 801
December	14 700	13 200	1 766 432
2002			
January	15 200	13 400	618 973
February	13 500	11 700	1 235 433
March	12 600	10 760	3 582 483
April	14 700	10 400	1 009 862
TRADING DAY			
2 May	14 360	13 700	4 232
3 May	14 700	14 300	11 168
6 May	14 800	14 100	41 750
7 May	14 400	14 100	45 505
8 May	14 800	14 300	12 108
9 May	14 900	14 360	19 928
10 May	14 600	14 480	1 940
13 May	14 600	14 350	10 467
14 May	14 800	14 500	12 805
15 May	14 700	13 901	29 289
16 May	14 100	13 800	29 035
17 May	14 000	13 600	65 851
20 May	14 020	13 900	55 260
21 May	14 020	13 900	7 097
22 May	13 980	13 500	2 492
23 May	13 680	13 100	71 769
24 May	14 200	13 990	34 797
27 May	14 400	14 120	4 715
28 May	14 220	14 000	24 257
29 May	14 400	14 080	4 490
30 May	14 480	14 250	55 963
31 May	14 400	14 210	104 752

Source: I-Net.

TABLE OF ENTITLEMENT OF INHOLD MEMBERS IN TERMS OF THE INHOLD UNBUNDLING

The table below sets out the entitlements of Inhold members, registered as such on the record date for the Inhold unbundling, to IGL ordinary shares to be distributed pursuant to the Inhold unbundling:

	Do not participate in the IGL unbundling ¹	Participate in the IGL unbundling ²				Do not participate in the IGL unbundling ¹	Participate in the IGL unbundling ²		
Number of Inhold ordinary shares	Entitlement to IGL ordinary shares in terms of the Inhold unbundling	Entitlement to IGL ordinary shares	Entitlement to Investec PLC ordinary shares	Total entitlement to IGL plus Investec PLC ordinary shares	Number of Inhold ordinary shares	Entitlement to IGL ordinary shares in terms of the Inhold unbundling	Entitlement to IGL ordinary shares in terms of the Inhold unbundling	Entitlement to Investec PLC ordinary shares	Total entitlement to IGL plus Investec PLC ordinary shares
1	1	–	1	1	51	44	16	28	44
2	2	1	1	2	52	45	17	28	45
3	3	1	2	3	53	46	17	29	46
4	3	1	2	3	54	46	17	29	46
5	4	1	3	4	55	47	17	30	47
6	5	2	3	5	56	48	18	30	48
7	6	2	4	6	57	49	18	31	49
8	7	3	4	7	58	50	19	32	51
9	8	3	5	8	59	51	19	32	51
10	9	3	6	9	60	52	19	33	52
11	9	3	6	9	61	52	19	33	52
12	10	4	6	10	62	53	20	33	53
13	11	4	7	11	63	54	20	34	54
14	12	4	8	12	64	55	20	35	55
15	13	5	8	13	65	56	21	35	56
16	14	5	9	14	66	57	21	36	57
17	15	6	9	15	67	58	21	37	58
18	15	6	9	15	68	59	22	37	59
19	16	6	10	16	69	59	22	37	59
20	17	6	11	17	70	60	22	38	60
21	18	7	11	18	71	61	23	38	61
22	19	7	12	19	72	62	23	39	62
23	20	7	13	20	73	63	23	40	63
24	21	8	13	21	74	64	24	40	64
25	22	8	14	22	75	65	24	41	65
26	22	8	14	22	76	65	24	41	65
27	23	9	14	23	77	66	24	42	66
28	24	9	15	24	78	67	25	42	67
29	25	9	16	25	79	68	25	43	68
30	26	10	16	26	80	69	26	43	69
31	27	10	17	27	81	70	26	44	70
32	28	10	18	28	82	71	26	45	71
33	28	10	18	28	83	71	26	45	71
34	29	11	18	29	84	72	27	45	72
35	30	11	19	30	85	73	27	46	73
36	31	11	20	31	86	74	27	47	74
37	32	12	20	32	87	75	28	47	75
38	33	12	21	33	88	76	28	48	76
39	34	13	21	34	89	77	28	49	77
40	34	13	21	34	90	77	28	49	77
41	35	13	22	35	91	78	29	49	78
42	36	13	23	36	92	79	29	50	79
43	37	14	23	37	93	80	30	50	80
44	38	14	24	38	94	81	30	51	81
45	39	14	25	39	95	82	30	52	82
46	40	15	25	40	96	83	31	52	83
47	40	15	25	40	97	83	31	52	83
48	41	15	26	41	98	84	31	53	84
49	42	16	26	42	99	85	31	54	85
50	43	16	27	43	100	86	32	54	86

- ¹ Applies to an Inhold member registered as such on the record date for the Inhold unbundling, but who trades the IGL ordinary shares due to him in terms of the Inhold unbundling on Friday, 19 July 2002 and does not participate in the IGL capital restructure and the IGL unbundling. In this regard, certificated Inhold members who want this to apply to them will need to dematerialise their Inhold ordinary shares, prior to Thursday, 11 July 2002.
- ² Applies to an Inhold member registered as such on the record date for the Inhold unbundling who does not trade the IGL ordinary shares due to him in terms of the Inhold unbundling and remains registered as such on the record date for the IGL capital restructure and the IGL unbundling in terms of which he will participate in the IGL capital restructure and the IGL unbundling. This will automatically apply to certificated Inhold members who do not dematerialise their Inhold ordinary shares prior to Thursday, 11 July 2002 and who do not trade the IGL ordinary shares due to them in terms of the Inhold unbundling on Friday, 19 July 2002.

It should be noted that an Inhold member's entitlement to IGL shares and/or Investec PLC ordinary shares will be rounded down to the nearest whole number if any fraction resulting is less than 0.5 or rounded up to the nearest whole number if any fraction resulting is equal to or greater than 0.5.

Inhold members resident in the US, Canada, Australia or Japan are requested to take note of the provisions of paragraph 8.1 of this circular.

TRADING HISTORY OF IGL ORDINARY SHARES ON THE JSE

The highest and lowest prices as well as the volumes at which IGL ordinary shares traded on the JSE for the second, third and fourth quarters of 1999, for each quarter of 2000, for the first quarter of 2001, for each month from April 2001 to April 2002 and for each trading day from 2 May 2002 to 31 May 2002, are set out below:

	High (cents)	Low (cents)	Volume
QUARTER ENDED			
1999			
30 June	25 720	21 800	5 717 021
30 September	25 800	18 440	5 103 737
31 December	28 200	19 480	5 389 963
2000			
31 March	30 000	24 400	4 398 022
30 June	26 500	20 000	5 197 678
30 September	25 000	21 700	3 555 734
31 December	25 500	21 200	17 253 550
2001			
31 March	27 800	19 200	7 734 149
MONTH ENDED			
April	22 560	17 600	4 084 145
May	23 600	20 020	3 787 927
June	24 600	21 500	4 413 202
July	24 400	20 000	3 872 640
August	21 000	18 400	5 601 399
September	20 320	15 000	10 707 766
October	16 900	14 800	5 282 895
November	18 500	14 300	5 547 168
December	17 300	15 300	3 124 610
2002			
January	18 160	15 800	3 125 143
February	16 100	13 700	5 725 131
March	15 060	12 880	5 148 721
April	17 600	12 500	5 404 079
TRADING DAY			
2 May	16 960	15 960	189 619
3 May	17 400	16 880	248 025
6 May	17 400	16 580	212 102
7 May	17 000	16 540	295 329
8 May	17 440	16 980	284 315
9 May	17 500	16 800	276 331
10 May	17 200	16 680	53 513
13 May	17 200	16 800	145 048
14 May	17 400	17 000	90 002
15 May	17 200	16 460	121 066
16 May	16 800	16 300	221 972
17 May	16 620	16 300	155 962
20 May	16 760	16 500	100 281
21 May	16 750	16 599	49 918
22 May	16 690	15 880	241 586
23 May	16 200	15 500	456 212
24 May	16 600	16 040	315 934
27 May	16 880	16 580	431 855
28 May	16 800	16 401	265 738
29 May	17 000	16 650	185 341
30 May	17 200	16 800	192 811
31 May	17 040	16 700	89 165

Source: I-Net.

TABLE OF ENTITLEMENT OF IGL MEMBERS IN TERMS OF THE IGL CAPITAL RESTRUCTURE AND THE IGL UNBUNDLING

The table below sets out the number of Investec PLC ordinary shares to which each IGL member, registered as such on the record date for the IGL unbundling, will be entitled to subsequent to the IGL capital restructure, together with the combined holding of IGL ordinary shares and Investec PLC ordinary shares after the IGL capital restructure and the IGL unbundling.

Number of IGL ordinary shares before the IGL capital restructure	Number of IGL ordinary shares after the IGL capital restructure	Entitlement to Investec PLC ordinary shares	Combined holding of IGL ordinary shares and Investec PLC ordinary shares after the IGL capital restructure and the IGL unbundling	Number of IGL ordinary shares before the IGL capital restructure	Number of IGL ordinary shares after the IGL capital restructure	Entitlement to Investec PLC ordinary shares	Combined holding of IGL ordinary shares and Investec PLC ordinary shares after the IGL capital restructure and the IGL unbundling
1	–	1	1	51	19	32	51
2	1	1	2	52	19	33	52
3	1	2	3	53	20	33	53
4	1	3	4	54	20	34	54
5	2	3	5	55	20	35	55
6	2	4	6	56	21	35	56
7	3	4	7	57	21	36	57
8	3	5	8	58	21	37	58
9	3	6	9	59	22	37	59
10	4	6	10	60	22	38	60
11	4	7	11	61	23	38	61
12	4	8	12	62	23	39	62
13	5	8	13	63	23	40	63
14	5	9	14	64	24	40	64
15	6	9	15	65	24	41	65
16	6	10	16	66	24	42	66
17	6	11	17	67	25	42	67
18	7	11	18	68	25	43	68
19	7	12	19	69	26	43	69
20	7	13	20	70	26	44	70
21	8	13	21	71	26	45	71
22	8	14	22	72	27	45	72
23	9	14	23	73	27	46	73
24	9	15	24	74	27	47	74
25	9	16	25	75	28	47	75
26	10	16	26	76	28	48	76
27	10	17	27	77	28	49	77
28	10	18	28	78	29	49	78
29	11	18	29	79	29	50	79
30	11	19	30	80	30	50	80
31	11	20	31	81	30	51	81
32	12	20	32	82	30	52	82
33	12	21	33	83	31	52	83
34	13	21	34	84	31	53	84
35	13	22	35	85	31	54	85
36	13	23	36	86	32	54	86
37	14	23	37	87	32	55	87
38	14	24	38	88	33	55	88
39	14	25	39	89	33	56	89
40	15	25	40	90	33	57	90
41	15	26	41	91	34	57	91
42	16	26	42	92	34	58	92
43	16	27	43	93	34	59	93
44	16	28	44	94	35	59	94
45	17	28	45	95	35	60	95
46	17	29	46	96	36	60	96
47	17	30	47	97	36	61	97
48	18	30	48	98	36	62	98
49	18	31	49	99	37	62	99
50	19	32	50	100	37	63	100

It should be noted that an IGL member's entitlement to IGL ordinary shares and Investec PLC ordinary shares will be rounded down to the nearest whole number if any fraction resulting is less than 0.5 or rounded up to the nearest whole number if any fraction resulting is equal to or greater than 0.5.

IGL members resident in the US, Canada, Australia or Japan are requested to take note of the provisions of paragraph 8.1 of this circular.

EXTRACTS FROM THE IGL ARTICLES

“VOTES OF MEMBERS

63. Votes attaching to shares

- 63.1 Subject to Article 50.4 *[relating to adjournment of general meetings]*, the provisions of Section 41(1) of the Banks Act and to any special rights or restrictions as to voting attached by or in accordance with these Articles to any class of shares:
- (a) on a show of hands every member being an individual who is present in person shall have one vote; and
 - (b) on a poll:
 - (i) every member who is present in person or by proxy (except the holder of the IL Special Converting Shares) shall have one vote for each fully paid share of which he is the holder; and
 - (ii) the holder of the IL Special Converting Shares shall have the Specified Number as defined in Article 63.2 of votes.
- 63.2 Prior to the Conversion Date *[being the time and date of termination of the Sharing Agreement in accordance with its terms]*, the holder of the IL Special Converting Shares shall be entitled to attend at any General Meeting and, subject to the provisions below, to cast on a poll the Specified Number, as set out below, of votes some of which may be cast for and others against any resolution in such numbers as the holder may determine.
- (a) **Joint Electorate Actions:** The Specified Number of votes in relation to a resolution of the Company on a Joint Electorate Action shall be the total number of votes validly cast on the poll on the equivalent resolution at the Parallel General Meeting of PLC (other than any cast in respect of PLC Disenfranchised Shares) multiplied by the Equalisation Fraction in effect at the time of such General Meeting rounded up to the nearest whole number.
 - (b) **Deleted intentionally.**
 - (c) **Procedural Resolutions:** On any procedural resolution put to a General Meeting at which a Joint Electorate Action is to be considered, the Specified Number of votes which may be cast shall be the greatest number of votes cast on any resolution on a Joint Electorate Action at the Parallel General Meeting of PLC or, if the General Meeting of PLC has not been held and such votes counted by the beginning of the relevant General Meeting, the greatest number of such votes as are authorised to be so cast upon proxies lodged with PLC by such time as the Chairman may determine, in each case, multiplied by the Equalisation Fraction in effect at the time of such General Meeting and rounded up to the nearest whole number.
 - (d) **Other decisions:** The Specified Number of votes that may be cast on all other decisions shall be zero.
- The IL Special Converting Shares shall not entitle its holder to vote on any show of hands.
- 63.3 Holders of the SA DAS Share and the SA DAN Share shall, by virtue of their holding respectively of the SA DAS Share and the SA DAN Share, have the right to receive notice of any General Meeting and to attend but not to vote at a General Meeting except if:
- (a) a resolution is to be proposed abrogating, varying or modifying any of the rights or privileges of the holders of the SA DAS Share and/or the SA DAN Share or which otherwise directly affects the rights attached to the SA DAS Share and/or SA DAN Share or the interests of the holders thereof or for the winding-up of the Company in which case they shall only be entitled to vote on such resolution; or
 - (b) any dividend or any part of any dividend or any redemption payment thereon remains in arrear and unpaid for a period of six months.
- 63.4 Where any share is allotted or issued or registered in the name of a person in contravention of the provisions of the Banks Act (“Contravening Shares”), the voting rights attached to the Contravening Shares shall, from the date on which such shares became Contravening Shares be incapable of being exercised and shall not carry any right to any distributions until such time as the Registrar of Banks or the Minister of Finance, as the case may be, has approved the acquisition or registration of the Contravening Shares.

DIRECTORS

76. Number of Directors

Subject as hereinafter provided the Directors shall not be less than four nor more than twenty in number. The Company may by special resolution from time to time vary the minimum number and/or maximum number of Directors.

77. Share qualification

A Director shall not be required to hold any shares in the capital of the Company by way of qualification. A Director who is not a member of the Company shall nevertheless be entitled to attend and speak at General Meetings.

78. Directors' fees

The ordinary remuneration of the Directors shall from time to time be determined by a disinterested quorum of the Directors except that such remuneration for both executive and non-executive Directors shall not exceed R1,000,000 per annum in aggregate or such higher amount as may from time to time be determined by ordinary resolution of the Company and shall, unless such resolution otherwise provides, be divisible among the Directors as they may agree, or, failing agreement, equally, except that any Director who shall hold office for part only of the period in respect of which such remuneration is payable shall be entitled only to rank in such division for a proportion of remuneration related to the period during which he has held office. Any fee payable under this Article shall be distinct from any remuneration or other amounts payable to a Director under other provisions of these Articles or payable by PLC under articles 78 to 80 of the PLC Memorandum and Articles.

79. Other remuneration of Directors

Subject to the JSE Listing Rules, any Director who holds any executive office with the Company or PLC, including for this purpose the office of Chairman or Deputy Chairman whether or not such office is held in an executive capacity, or who serves on any committee of the Board, or who otherwise performs services in relation to the business of the Company and/or PLC which are outside the scope of the ordinary duties of a Director, may be paid such extra remuneration by way of salary, commission or otherwise or may receive such other benefits, including, without limitation, costs associated with residing overseas, as a disinterested quorum of Directors may reasonably determine.

80. Directors' expenses

The Directors may repay to any Director all such reasonable expenses as he may incur in attending and returning from meetings of the Board, meetings of any committees appointed pursuant to Article 103 [*relating to committees of the Directors*] or General Meetings or otherwise in connection with the business of the Company or PLC.

81. Directors' pensions and other benefits

The Directors shall have power to pay and agree to pay gratuities, pensions or other retirement, superannuation, death or disability benefits to or to any person in respect of any Director or ex-Director and for the purpose of providing any such gratuities, pensions or other benefits to contribute to any scheme or fund or to pay premiums.

85. Retirement by rotation

Subject to article 90, each Director shall retire by rotation at the Annual General Meeting held in the third calendar year following the year in which he was elected or last re-elected. A director retiring by rotation shall be eligible for re-election.

87. Re-election of retiring Director

The Company at the meeting at which a Director retires under any provision of these Articles may by ordinary resolution approved in accordance with Article 61.2 fill the office being vacated by electing thereto the retiring Director or some other person eligible for election. The retirement shall not have effect until the conclusion of the meeting except where a resolution is passed to elect some other person in the place of the retiring Director or a resolution for his re-election is put to the meeting and passed and accordingly a retiring Director who is re-elected will continue in office without a break.

89. Nomination of Director for election

89.1 No person other than a Director retiring at a General Meeting shall be eligible for election as a Director at that General Meeting unless there shall have been lodged at the Office [*being the registered office of the company*]:

- (a) notice in writing signed by a member, other than the person to be proposed, duly qualified to attend and vote at the meeting or a Director for which such notice is given of his intention to propose such person for election;
- (b) notice in writing signed by the person to be proposed of his willingness to be elected as a Director of the Company and a director of PLC.

The Directors shall nominate for election as a Director at a General Meeting of the Company any person duly nominated for election at the Parallel General Meeting of

89.2 The notice required under Article 89.1 must be lodged not less than seven and not more than twenty-eight Business Days (inclusive of the date on which notice is given) before the earlier of the date appointed for the meeting and the date appointed for the Parallel General Meeting of PLC.

90. Election or appointment of additional Director

The Company may by ordinary resolution approved in accordance with Article 62 elect, and without prejudice thereto the Directors shall have power at any time to appoint, any person to be a Director either to fill a casual vacancy or as an additional Director; but so that: (i) the total number of Directors shall not thereby exceed the maximum number fixed by or in accordance with these Articles and (ii) the appointment shall not take effect before such Director has been duly appointed as a director of PLC. Any person so appointed by the Directors, except for the directors of PLC appointed as Directors by the Directors on or about the date of the Sharing Agreement, shall hold office only until the next Annual General Meeting and shall then be eligible for re-election, save that the Directors who hold office at the date of adoption of these Articles shall not be required to vote at the next Annual General Meeting and shall for the purposes of Article 85 be deemed to have been elected on 25 July 2002.

100. Directors may have interests

Subject to the provisions of the Statutes, and provided that he has disclosed to the Directors the nature and extent of any interest of his, a Director notwithstanding his office:

- (a) may be a party to, or otherwise interested in, any contract, transaction or arrangement with the Company or PLC or in which the Company or PLC is otherwise interested;
- (b) may be a director or other officer of, or employed by, or a party to any contract, transaction or arrangement with, or otherwise interested in, any body corporate promoted by the Company or PLC in which the Company or PLC is otherwise interested, provided that a Director may not accept such office or employment, enter into any such contract, transaction, or arrangement or take such interest or receive remuneration in relation to any of the foregoing without the prior approval of a disinterested quorum of Directors;
- (c) may (or any firm of which he is a partner, employee or member may) act in a professional capacity for the Company or PLC (other than as Auditor) and be remunerated therefore provided that any appointment so to act and the remuneration for such appointment shall require the prior approval of a disinterested quorum of Directors; and
- (d) shall not, save as otherwise agreed by him, be accountable to the Company for any benefit which he derives from any such contract, transaction or arrangement or from any such office or employment or from any interest in any such body corporate or for such remuneration and no such contract, transaction or arrangement shall be liable to be avoided on the grounds of any such interest or benefit.

101. Restrictions on voting

101.1 Save as herein provided, a Director shall not vote in respect of any contract, transaction or arrangement or any other proposal whatsoever in which he has any material interest otherwise than by virtue of interests in shares or debentures or other securities of, or otherwise in or through, the Company. A Director shall not be counted in the quorum at a meeting in relation to any resolution on which he is not entitled to vote.

- 101.2 Subject to the provisions of the Statutes, a Director shall, in the absence of some other material interest than is indicated below, be entitled to vote and be counted in the quorum in respect of any resolution concerning any of the following matters, namely:
- (a) the giving of any security, guarantee or indemnity in respect of (i) money lent or obligations incurred by him or by any other person at the request of or for the benefit of the Company or any of its Subsidiaries or Associated Companies (ii) a debt or other obligation of the Company any of its Subsidiaries or Associated Companies for which he himself has assumed responsibility, in whole or in part and whether alone or jointly with others, under a guarantee or indemnity or by the giving of security;
 - (b) any proposal concerning an offer of shares or debentures or other securities of or by the Company or any of its Subsidiaries or Associated Companies in which offer he is or may be entitled to participate as a holder of securities or in the underwriting or sub-underwriting of which he is to participate;
 - (c) any proposal concerning any other body corporate in which he is interested, directly or indirectly, and whether as an officer or shareholder, creditor or otherwise, provided that he, together with persons related to him within the meaning given to it in the JSE Listing Rules, does not have an interest (as that term is used in Section 234 of the Act) in one per cent or more of either the issued equity share capital of any class of such body corporate or of any third company through which his interest is derived or of the voting rights available to members of the relevant body corporate, any such interest being deemed for the purpose of this Article to be a material interest in all circumstances;
 - (d) any proposal relating to an arrangement for the benefit of the employees of the Company or any of its Subsidiaries or Associated Companies which does not award him any privilege or benefit not generally awarded to the employees to whom such arrangement relates; and
 - (e) any proposal concerning insurance which the Company proposes to maintain or purchase for the benefit of Directors or for the benefit of persons who include Directors.
- 101.3 Where proposals are under consideration concerning the appointment, including without limitation fixing or varying the terms of appointment, of two or more Directors to offices or employments with the Company or any body corporate in which the Company is interested, the proposals may be divided and considered in relation to each Director separately and in such case each of the Directors concerned, if not debarred from voting under this Article, shall be entitled to vote and be counted in the quorum in respect of each resolution except that concerning his own appointment.
- 101.4 If a question arises at any time as to the materiality of a Director's interest or as to his entitlement to vote and such question is not resolved by his voluntarily agreeing to abstain from voting, such question shall be referred to the chairman of the meeting and his ruling in relation to any Director other than himself shall be final and conclusive except in a case where the nature or extent of the interest of such Director has not been fairly disclosed. If any such question arises in respect of the chairman of the meeting, it shall be decided by resolution of the Directors on which the chairman shall not vote and such resolution will be final and conclusive except in a case where the nature and extent of the interests of the chairman have not been fairly disclosed.
- 101.5 Despite having an interest in any contract or arrangement a Director may participate in the execution of any document evidencing or connected with the contract or arrangement whether by signing or otherwise.

102. Directors' interests – general

For the purposes of the two preceding Articles:

- (a) a general notice given to the Directors that a Director is to be regarded as having an interest of the nature and extent specified in the notice in any contract, transaction or arrangement in which a specified person or class of persons is interested shall be deemed to be a disclosure that the Director has an interest in any such contract, transaction or arrangement of the nature and extent so specified;
- (b) an interest of a person who is related (within the meaning given to it in the JSE Listing Rules) with a Director shall be treated as an interest of the Director; and

- (c) an interest, whether of his or of such a related person, of which a Director has no knowledge and of which it is unreasonable to expect him to have knowledge shall not be treated as an interest of his.

106. Powers and obligations in relation to the DLC Agreements

The Company having entered into the DLC Agreements, the Directors are authorised and directed, subject to Applicable Regulation, to carry into effect the provisions of the DLC Agreements and any further or other agreements or arrangements contemplated by or relating to such agreements and nothing done by any Director in good faith pursuant to such authority and obligations (the "DLC Obligations") shall constitute a breach of the fiduciary duties of such Director to the Company or to the members of the Company. In particular, but without prejudice to the generality of the foregoing, the Directors may in addition to their duties to the Company have regard to the interests of PLC and both the holders of PLC Ordinary Shares and IGL Ordinary Shares as if the Company and PLC were a single unified entity and for that purpose the Directors shall in exercising their powers take into account the interests of the holders of PLC Ordinary Shares;

In the absence of fraud or negligence, neither the Company nor any member(s) shall have the right to bring any proceedings or claims against any Director(s) which arises out of or in connection with anything done in good faith by any Director(s) or the Board pursuant to the DLC Obligations.

111. Borrowing powers and restrictions

Subject to the provisions of the Statutes, the Directors may exercise all the powers of the Company to borrow money, to indemnify, to guarantee, to mortgage or charge its undertaking, property, assets (present and future) or any part or parts thereof and to issue debentures and other securities, whether outright or as collateral security for any debt, liability or obligation of the Company or of any third party.

RIGHTS TO DIVIDENDS

125. Record date for dividends

Any resolution for the declaration or payment of a dividend on shares of any class, whether a resolution of the Company in General Meeting or a resolution of the Directors, may specify that the same shall be payable to the persons registered as the holders of such shares at the close of business on a particular date, provided that it may not be a date prior to that on which the dividend is declared or payment thereof is confirmed, whichever is the later, and thereupon the dividend shall be payable to them in accordance with their respective holdings so registered, but without prejudice to the rights *inter se* in respect of such dividend of transferors and transferees of any such shares.

128. Unclaimed dividend

The payment by the Directors of any unclaimed dividend or other moneys payable on or in respect of a share into a separate account shall not constitute the Company a trustee in respect thereof and any dividend unclaimed after a period of six years from the date on which such dividend was declared or became due for payment shall be forfeited and shall cease to remain owing by the Company. For the purpose of this Article "unclaimed dividends" shall include, if a dividend has been paid in respect of the SA DAN Share and/or the SA DAS Share and part or all of such dividend has not been claimed by the beneficiaries under the SA DANT or SA DAST, as the case may be, within a period of six years from the date on which such dividend was declared or became due for payment, the amounts so unclaimed.

WINDING UP

144. Directors' power to petition

The Directors shall, with the approval of the shareholders in General Meeting, have power in the name and on behalf of the Company to apply to the Court for the Company to be liquidated.

145. Distribution of assets *in specie*

Subject to Article 5.2, if the Company shall be liquidated (whether the liquidation is voluntary, or by the Court) the liquidator may, with the authority of a special resolution, divide among the members *in specie* or kind the whole or any part of the assets of the Company and whether or not the assets shall consist of property of one kind or shall consist of properties of different kinds, and may for such purpose set such value as he deems fair upon any one or

more class or classes of property and may determine how such division shall be carried out as between the members or different classes of members. The liquidator may, with the like authority, vest the whole or any part of the assets in trustees upon such trusts for the benefit of members as the liquidator with the like authority shall think fit, and the liquidation of the Company may be closed and the Company dissolved, but so that no member shall be compelled to accept any shares or other property in respect of which there is a liability.

SHARE CAPITAL

4. IL Special Converting Shares

On the Conversion Date, all of the IL Special Converting Shares shall automatically be converted into and in all respects rank *pari passu* with the IL Ordinary Shares and otherwise the rights of such shares prior to the Conversion Date shall be as set out in these Articles.

5. Income and capital rights

5.1 The rights attaching to the shares as regards participation in the profits of the Company are set out below.

- (a) Prior to the Conversion Date:
 - (i) the profits available for distribution and resolved to be distributed shall be distributed among the holders of the IL Ordinary Shares, the SA DAN Share and the SA DAS Share in such a manner as would ensure that the distributions made, when taken together with any Initial Action or Matching Action, as the case may be, are such that the Company will have complied with its obligations under Clause 3 of the Sharing Agreement; and
 - (ii) the IL Special Converting Shares shall have no right to receive any dividends or other distributions.
- (b) On and from the Conversion Date:
 - (i) the profits available for distribution and resolved to be distributed shall be distributed among the holders of IL Ordinary Shares save as regards any distribution payable by reference to a record date prior to the Conversion Date which shall not be payable to the holders of IL Special Converting Shares which have converted in accordance with Article 4; and
 - (ii) the SA DAN Share and SA DAS Share shall have no right to receive any dividends or other distributions.

5.2 On a winding-up of the Company, the assets of the Company remaining after payment of all amounts payable to the creditors of the Company and prior ranking statutory entitlements shall be distributed,

- (a) first to the holders of the SA DAN Share and the SA DAS Share subject, in each case, to a maximum of the par value of such shares; and
- (b) subject to (a) above, to the holders of IL Ordinary Shares.

UNTRACED SHAREHOLDERS

46. Untraced Shareholders

46.1 The Company shall be entitled to sell, at the best price reasonably obtainable at the time of sale, the shares of a member or the shares to which a person is entitled by virtue of transmission on death or insolvency or otherwise by operation of law if and provided that:

- (a) during the period of six years prior to the date of the publication of the advertisements referred to in Article 46.1(b) below, or, if published on different dates, the first thereof, at least three dividends in respect of the shares in question have become payable and all dividend warrants and cheques which have been sent in the manner authorised by these Articles have remained uncashed; and
- (b) the Company shall as soon as practicable on expiry of such period of six years have inserted advertisements in both a national daily newspaper and in a newspaper circulating in the area in which the last known address of the member or the address at which service of notices may be effected under these Articles is located giving notice of its intention to sell the said shares; and
- (c) during the period of three months following the publication of such advertisements, the Company shall have received no indication either of the whereabouts or of the existence of such member or person.

- 46.2 To give effect to any such sale the Directors may appoint any person to transfer; as transferor; the said shares and such transfer shall be as effective as if it had been carried out by the registered holder of or person entitled by transmission to such shares and the title of the transferee shall not be affected by any irregularity or invalidity in the proceedings relating thereto. The net proceeds of sale shall belong to the Company which shall be obliged to account to the former member or other person previously entitled as aforesaid for an amount equal to such proceeds and shall enter the name of such former member or other person in the books of the Company as a creditor for such amount which shall be a permanent debt of the Company. No trust shall be created in respect of the debt, no interest shall be payable in respect of the same and the Company shall not be required to account for any money earned on the net proceeds of sale, which may be employed in the business of the Company or invested in such investments, other than shares of the Company or its holding company if any, as the Directors may from time to time think fit.
- 46.3 In the case of shares in uncertificated form, the foregoing provisions of this Article are subject to any restrictions applicable under the STRATE Regulations.

VOTING RIGHTS AND PROCEDURES UNDER SHARING AGREEMENT

61. Class Rights Actions

- 61.1 The following matters shall constitute Class Rights Actions:
- (a) amendment or termination of the Sharing Agreement, the Voting Agreement, the SA DAT Deeds, the UK DAT Deeds or the SCS Deeds other than:
 - (i) any amendment to conform the Voting Agreement, the SA DAT Deeds, the UK DAT Deeds or the SCS Deeds with the terms of the Sharing Agreement; or
 - (ii) any amendment which is formal or technical in nature and which would not be materially prejudicial to the interests of the shareholders of the Company or is necessary to correct any inconsistency or manifest error;in each case as agreed between the Board and the Board of PLC;
 - (b) any amendment to, or removal of, or the alteration of the effect of which for the avoidance of doubt shall be taken to include the ratification of any breach of, any PLC Entrenched Provision or IL Entrenched Provision other than:
 - (i) any amendment to conform such provisions with the terms of the Sharing Agreement; or
 - (ii) any amendment which is formal or technical in nature and which would not be materially prejudicial to the interests of the shareholders of the Company or is necessary to correct any inconsistency or manifest error;in each case as agreed between the Board and the Board of PLC;
 - (c) any Action in respect of which a Matching Action or an adjustment to the Equalisation Ratio would be required pursuant to Clause 3 of the Sharing Agreement, but where no such Matching Action is to be taken or adjustment made; and
 - (d) any other action or matter which the Board and the Board of PLC agree, either in a particular case or generally, should be treated as a Class Rights Action.
- 61.2 A Class Rights Action in respect of an action of a kind described in:
- (a) paragraphs 61.1(a) or (b) shall require approval by special resolution;
 - (b) paragraph 61.1(c) shall require approval by ordinary resolution or, if required by Applicable Regulation applying to the Company or PLC or by these Articles or the Investec PLC Memorandum and Articles, by special resolution of the Company or PLC, as so required; and
 - (c) paragraph 61.1(d) shall require approval by ordinary resolution or, if required by Applicable Regulation applying to the Company or PLC or by these Articles or the PLC Memorandum and Articles or if considered appropriate by the Board and the Board of PLC, by special resolution of the Company or PLC, as so required,
- in each case in accordance with the provisions of Articles 61.3 and the percentage vote in favour of the types of resolution specified above shall be referred to as the "**Required Majority**".

- 61.3 Any resolution (a “**Relevant Resolution**”) to approve a Class Rights Action shall not be effective unless it is passed by (i) a vote in favour of at least the Required Majority of the votes cast by the holders of the PLC Ordinary Shares and the PLC Special Voting Share voting as a single class, (ii) a vote in favour of at least the Required Majority of the holders of the IL Ordinary Shares and (iii) the written consent of the holder of the IL Special Converting Shares, and such approvals and consents shall be obtained in accordance with the procedures set out below.
- (a) PLC shall hold a General Meeting at which both the holders of PLC Ordinary Shares and the holder of the PLC Special Voting Share are entitled to vote on a poll as a single class on the Relevant Resolution. The poll shall not be closed in relation to the PLC Special Voting Share until its holder has either cast its vote on such resolution or given written notice that it will not vote in accordance with paragraph 61.3(e).
 - (b) The Company shall hold a Parallel General Meeting of the holders of the IL Ordinary Shares to vote on the Relevant Resolution.
 - (c) When the votes cast by the holders of PLC Ordinary Shares have been determined, PLC will send to the Company and to the holder of the IL Special Converting Shares written notice confirming whether or not the Relevant Resolution has been approved by the Required Majority of the holders of PLC Ordinary Shares.
 - (d) When the result of vote on the Relevant Resolution at the meeting of the holders of IL Ordinary Shares has been declared or determined, the Company will send to PLC and the holder of the PLC Special Voting Share written notice confirming whether or not the Relevant Resolution has been approved by the Required Majority.
 - (e) The holder of the PLC Special Voting Share shall:
 - (i) on receipt of a notice from the Company confirming the Required Majority has been obtained, not vote on the resolution and shall send written notice to PLC to this effect; and
 - (ii) on receipt of a notice from the Company confirming the Required Majority has not been obtained, vote against the relevant transaction and, in accordance with Article 63.2(b), shall have sufficient votes to defeat such resolution.
 - (f) The holder of the IL Special Converting Shares shall:
 - (i) on receipt of a notice from PLC confirming the Required Majority has been obtained, give its written consent to the Relevant Resolution; and
 - (ii) on receipt of a notice from PLC confirming the Required Majority has not been obtained, withhold its written consent to the Relevant Resolution.

151. Class “A” Variable Rate Compulsory Convertible Non-Cumulative Preference Shares

151.21 Notwithstanding the provisions of Article 151.7 [*compulsory conversion*], the Company shall in its sole discretion be entitled to convert all or any part of the Convertible Preference Shares held by any Convertible Preference Shareholder:

- (a) by written notice from the Company to the Convertible Preference Shareholder in a form and manner to be determined by the Directors; or
- (b) at any time after expiry of three years after the date of issue of the Convertible Preference Shares, at the request of such Convertible Preference Shareholder; provided that the Company agrees to such conversion;

on the basis of one Ordinary Share for each Convertible Preference Share held.”

CONTINUING RIGHTS UNDER THE IGL EMPLOYEE OWNERSHIP SCHEMES, THE ADOPTION OF THE IGL 2002 SCHEME AND SALIENT FEATURES OF THE INVESTEC PLC EMPLOYEE SHARE PLANS AND THE INVESTEC PLC EMPLOYEE TRUSTS

The salient features of continuing rights under the IGL employee ownership schemes and the IGL 2002 share scheme are set out below paragraphs 1 – 4 below. Paragraph 5 sets out salient features of the Investec PLC employee share plans and the Investec PLC employee trusts.

1. CONTINUING RIGHTS UNDER THE IGL SHARE SCHEME

The terms and operation of the current IGL share scheme are substantially the same as the IGL Security Purchase and Option Scheme 2002, described in paragraph 4 of this annexure XV below

No further options will be granted under the option scheme part of the IGL share scheme, and no further securities will be offered under the purchase scheme part of the IGL share scheme.

Following Admission, participants in the purchase scheme part of the IGL share scheme will have rights in respect of both IGL ordinary shares and Investec PLC ordinary shares, in the same way as other shareholders. The Investec PLC ordinary shares will be subject to the same terms and conditions as the original IGL ordinary shares to which they relate.

As at 30 April 2002, 492 871 IGL ordinary shares, 4 632 603 Inhold ordinary shares and 1 860 000 debentures convertible on a one for one basis (at the choice of the debenture holder) to IGL ordinary shares are held in the purchase scheme part of the IGL share scheme. Following Admission, there will be 1 657 142 IGL ordinary shares and 2 821 621 Investec PLC ordinary shares held, and 1 860 000 debentures will be held in respect of 1 860 000 IGL ordinary shares, in the purchase scheme part of the IGL share scheme.

It is proposed to vary outstanding options under the IGL share scheme so that they are in respect of both IGL ordinary shares and Investec PLC ordinary shares, on the same basis as applicable to shareholders. It is intended that the varied options shall be of equivalent value to the original options.

As at 30 April 2002, options are outstanding over 2 874 000 IGL ordinary shares and 6 893 Inhold ordinary shares under the option scheme part of the IGL share scheme. Following the proposed variation, there will be 1 065 605 IGL ordinary shares under option and 1 814 410 Investec PLC ordinary shares under option.

2. CONTINUING RIGHTS UNDER FINTIQUE II

Fintique II was constituted as a unit trust, available to selected executives and senior employees of IGL. Investec Bank issued compulsory convertible debentures to IGL. IGL sold the right to the income and the right to receive the redemption monies on redemption of the debentures to third parties, retaining the right to acquire and the obligation to pay for the Investec Bank ordinary shares which would arise on redemption and conversion. IGL sold the Investec Bank ordinary shares to Fintique II.

Initial subscriptions were offered by the trustee of Fintique II (the "Trustee") to participants at the market value of the units. The contributions made by the participants were used by Fintique II to make an initial payment for the Investec Bank ordinary shares and to start a sinking fund, intended to pay the balance of the purchase price of the Investec Bank ordinary shares when due. As security for the contingent obligations to Fintique II (if the sinking fund turns out to be insufficient to pay the cost of acquisition of the Investec Bank ordinary shares), participants are bound jointly for their share of the shortfall as sureties and have pledged their units to Fintique II.

Participants who subscribed for units acquired the benefits and risks of ownership of those units and accordingly, under South African trust law, acquired a personal right against the Trustee, which is an interest in the rights to the Investec Bank ordinary shares acquired by Fintique II. The units cannot be sold, except back to Fintique II if the Trustee agrees, to varying extents and for varying periods. Fintique II will generally repurchase a unit at a price equivalent to the participant's cost, adjusted to take account of the sinking fund. Once the sale restriction ends, units may be traded, but only among the participants. After six years, or earlier in the event of death or retirement, participants may apply to the trustees of the current IGL Share Schemes to exchange their units for shares. Fintique II has agreed with Inhold to

exchange the Investec Bank ordinary shares acquired for shares in Inhold, resulting in participants receiving Inhold ordinary shares. Under the terms of a re-arrangement agreement effective from 18 June 2002, the exchange agreement with Inhold has been cancelled and Fintique II has agreed with IGL to accept shares in IGL in exchange for its Investec Bank ordinary shares on the same basis as if the exchange agreement with Inhold had not been cancelled and the exchange for Inhold ordinary shares had taken place before the Inhold unbundling. Fintique II will swap a percentage of the shares in IGL with the trustees of the IGL share scheme for shares in Investec PLC.

3. CONTINUING RIGHTS UNDER FINTIQUE III

Fintique III was constituted in Guernsey as a unit trust available to employees and directors of IGL invited by the board of directors of IGL to acquire units in the unit trust. Fintique III is the sole owner of Fintique Three BVI Limited ("**Fintique Three BVI**").

The participants in Fintique III subscribed for units and made contributions to Fintique III calculated at the market value of the units and have an unquantified contingent obligation to make up any shortfall in Fintique III. As security for their contingent obligations to Fintique III the participants have pledged their units to Fintique III.

Participants who subscribe for units in Fintique III acquire the benefits and risks of ownership of those units and accordingly under South African trust law acquire a personal right against the trustee of Fintique III which is the interest of Fintique III in Fintique Three BVI.

Units in Fintique III may not be sold by participants for predetermined extents and periods except to Fintique III if the trustee of Fintique III agrees to acquire the units. After the sale restrictions have ended, participants may sell their units but the trustee of Fintique III has a right of first refusal. If the trustee of Fintique III does not choose to acquire the units, the units may be traded, but only, among participants.

If a participant dies or retires or leaves IGL for any other reason, approved by the board of directors of Inhold, the sale restriction on the units ends. The trustee of Fintique III may then acquire the units at their market value. If a participant leaves IGL for any other reason or is declared insolvent, the trustee of Fintique III may require him to sell his units. Those units which are not subject to sale restrictions may be acquired by Fintique III at the then market value, and units which are still subject to sale restrictions may be acquired at the lesser of market value or, usually, the original cost of subscription of the unit.

Investec Bank issued compulsory convertible debentures and Fintique Three BVI acquired the right to receive the redemption moneys on redemption of the debentures and the right to acquire (and the obligation to pay for) the Investec Bank ordinary shares which would arise on redemption and conversion, the rights to the income on the debentures having been sold off.

Fintique Three BVI entered into an agreement with IGL under which the Investec Bank ordinary shares would be exchanged for IGL ordinary shares. Fintique III also entered into an agreement with Inhold under which the IGL ordinary shares which it was to acquire in terms of the exchange agreement would be sold to Inhold for shares in Inhold ("the exchange agreements").

Under the terms of the re-arrangement agreement, Fintique Three BVI has agreed that, effective as from 18 June 2002, the exchange agreements have been cancelled and Fintique Three BVI has ceded its rights to the redemption monies in respect of the debentures and delegate its obligations to subscribe for the Investec Bank ordinary shares to IGL for a consideration which is immediately applied by Fintique Three BVI in the subscription for IGL ordinary shares. The IGL ordinary shares which Fintique Three BVI has acquired will accordingly convert into new IGL ordinary shares and Investec PLC ordinary shares on the same basis as for any other shareholder in IGL.

4. THE IGL SECURITY PURCHASE AND OPTION SCHEME ("THE IGL 2002 SCHEME")

(a) Legal structure

The IGL 2002 scheme is operated by a trust governed by South African trust law. The trustees of the trust ("the Trust") are Werksmans Trustees (Proprietary) Limited and Sam Abrahams (a non-executive director of IGL).

(b) Operation

The trust operates two schemes: a purchase scheme and an option scheme described in paragraphs 4(f) and 4(g) below.

The securities used in the schemes include marketable securities (including convertible shares or debentures) issued by IGL, its holding or controlling company, subsidiaries of IGL or its holding or controlling company, or any associate of those companies; units issued by Fintique II; shares issued by Investec PLC; units in any other trust constituted to assist employees of the IGL group; and listed or unlisted marketable securities issued by companies whose major asset is any interest in a listed instrument issued by IGL or Investec PLC or any of their subsidiary or associated companies. Investec PLC will receive full market value at the relevant time in respect of any shares issued to the trustee of the IGL 2002 scheme to be used for the purposes of the IGL 2002 scheme or issued otherwise in respect of IGL's share plans.

(c) *Eligibility*

Employees and executive directors of IGL and any participating subsidiary who are more than six months before their anticipated retirement date are eligible to participate in the IGL 2002 scheme. An IGL board committee on remuneration, which consists entirely of non-executive directors ("the remuneration committee") will decide which employees or executive directors will participate in the IGL 2002 scheme, whether they will participate in the purchase scheme or the option scheme, and the number of shares to which such employees or executive directors are entitled. Trusts and companies owned by or constituted for the benefit of such persons and their direct families may become participants.

(d) *Individual limits*

The maximum number of securities which any one participant may actually or contingently be entitled to acquire under the IGL 2002 scheme any other incentive schemes established by Investec may not exceed 500,000 IGL ordinary shares and Investec PLC ordinary shares in total, taking into account any conversion rights.

(e) *Plan limit*

No offer of securities may be made to the extent that, after acceptance of such offer, the aggregate number of scheme securities held under the purchase scheme, together with securities which may be acquired on the exercise of options granted and accepted under the option scheme and in terms of all other staff share incentive schemes of IGL would confer the direct or indirect right to or beneficial interest in more than 10% of the ordinary shares in IGL and Investec PLC (direct or indirect and after taking into account of any conversion rights), or such increased percentage of ordinary shares as may from time to time be approved by the JSE.

(f) *Purchase scheme*

The participants agree to purchase the securities and take on the benefits and risks of ownership. Participants in the purchase scheme are loaned the acquisition price by the trustees. They may pay any part of it at any time but must pay at least 10 per cent. of the aggregate amount of such loan each year after an initial two-year period.

The securities are pledged to the trust as security for the participant's loan. The securities may only be released as to:

- up to 25 per cent. of the original number of securities between the second and third anniversaries of the date of acquisition;
- up to 50 per cent. of the original number of securities between the third and fourth anniversaries of the date of acquisition;
- up to 75 per cent. of the original number of securities between the fourth and fifth anniversaries of the date of acquisition; and
- up to 100 per cent. of the original number of securities on and after the fifth anniversary of the date of acquisition.

Securities may only be released on full payment provided the participant remained employed by Investec.

If a participant dies in service, retires or leaves Investec for any reason which the directors deem to be good and sufficient, the participant (or in the case of his death, his executor) has the right to take up and pay for the securities he has purchased, or to resell them to the trust. If a participant is dismissed or leaves Investec for any other reason, the trustees may require him to purchase all or some of the shares at the acquisition price or alternatively the trustees may repurchase the securities. The price at which the trustees repurchase securities is the lesser of the market value of the securities or the outstanding loan obligation adjusted for any payments previously made.

(g) *Option scheme*

Options may be granted by IGL or, with the consent of IGL, by the trustee of an employee benefit trust established by IGL.

The purchase price payable by participants for their securities will be their market price, which is determined as follows: If the securities are listed on the JSE, the closing price of the securities on the trading day immediately prior to the date of the grant of the option or, if the securities are not so listed, the price determined by the directors of IGL as being the fair market price of the securities on the date immediately prior to that on which the option is granted to the participant, having regard to matters including the terms and conditions of the issue of the security and, if applicable, the price of the listed security into which it is convertible.

Options will normally be exercisable while the participant is employed by Investec.

Options become exercisable in tranches of 25 per cent. on each anniversary of the date of grant starting on the second and ending on the fifth anniversary. To the extent that the option has not been exercised within 90 days it will lapse in respect of the securities covered by that tranche.

Options may be exercised if the participant dies in service, retires or leaves Investec for any reason which the directors of IGL deem to be good and sufficient. If he dies, his estate may exercise all his options. If he retires or leaves for any other reason, which the directors of IGL deem to be good and sufficient, options may only be exercised to the extent set out above unless the directors of IGL decide otherwise. If the participant is dismissed or leaves Investec for any other reason, all his options lapse.

Options may also generally be exercised early on a takeover, reconstruction or winding-up of IGL, or if there is a demerger or other significant distribution affecting IGL. If there is a change in control of IGL, and in certain other circumstances, participants may, as an alternative to exercising their options, be allowed or required to exchange their options for options over shares in the acquiring company. Options may be adjusted to take account of a variation in IGL's share capital. In certain specific circumstances, the option price may be adjusted below the nominal value of the IGL shares. Options may also be adjusted in specific circumstances which may arise as a result of economic equalisation mechanics under the DLC Structure (see paragraph 6 of Annexure I).

5. INVESTEC PLC EMPLOYEE SHARE PLANS AND INVESTEC PLC EMPLOYEE TRUSTS

Employees of Investec PLC may be offered participation in some or all of the Investec PLC employee share plans described below.

5.1 Common features

The following features are common to each of the Investec PLC employee share plans (the "Plans").

Shareholder approval will be required to amend certain provisions of the Plans to the advantage of participants. These provisions relate to: eligibility; individual and dilution limits; option price; rights attaching to options or shares; adjustment of options on a variation in Investec PLC's share capital; and the amendment powers. The directors of Investec PLC may make other amendments as they consider appropriate, but alterations to the Investec PLC Share save Option Plan 2002, the Investec PLC Approved Share Option Plan 2002 (the "Approved Plan") and the Investec PLC Share Participation Plan 2002 are generally subject to the prior approval of the UK Inland Revenue.

The directors of Investec PLC can, without seeking further shareholder approval, make amendments to obtain or maintain UK Inland Revenue approval; make minor amendments to benefit the administration of the Plans or which relate to any changes in legislation, or which will obtain or maintain favourable tax, exchange control or regulatory treatment for any participant; and adopt further plans, based on the Plans, to take account of tax, exchange control or securities laws which apply to non-United Kingdom employees.

Options and other rights granted under the Plans are not pensionable and are granted for no consideration.

In any ten-year period, not more than 10 per cent. of the issued ordinary share capital of Investec PLC may be issued or issuable under the Plans and all other employees' share plans operated by Investec PLC. In addition, in any ten year period, not more than 5 per cent. of the issued ordinary share capital of Investec PLC may be issued or be issuable under all discretionary share plans adopted by Investec PLC. These limits do not include options or other rights which have lapsed or been surrendered, nor will they include options or other rights which may

only be satisfied using shares purchased in the market, or Investec PLC ordinary shares issued in respect of obligations entered into before Admission, including Investec PLC ordinary shares to be issued on the exercise of options granted under the Investec PLC Share Option Plan 2002 in conjunction with the adjustment of IGL options (see paragraph 5.9 below). These limits do not, however, apply under the Investec PLC Share Appreciation Option Plan 2002, under which employees have a right to receive a cash sum by reference to IGL ordinary shares. These limits do not include any Investec PLC ordinary shares issued pursuant to the IGL 2002 scheme or any other employee share plan or trust operated by IGL (see paragraph 4 above).

Any Investec PLC ordinary shares issued under the Plans will rank equally with Investec PLC ordinary shares of the same class in issue on that date of allotment except in respect of rights arising by reference to a prior record date. Application will be made to the UK Listing Authority for the Investec PLC ordinary shares to be admitted to the Official List and to the London Stock Exchange for the Investec PLC ordinary shares to be admitted to trading.

All the Plans will terminate ten years after their approval by Investec PLC's shareholders, or earlier if the directors of Investec PLC decide. Termination will not affect outstanding options and other rights, but no new rights may be granted under the Plans after termination.

5.2 The Investec PLC Share Option Plan 2002 (the "Option Plan")

(a) Operation

Options under the Option Plan may be granted on Investec PLC ordinary shares or other shares or debentures in Investec PLC (all referred to as "shares" in this paragraph 5.2)

Options may be granted by Investec PLC, or with the consent of the directors of Investec PLC, be granted by the trustee of an employee trust established by Investec PLC. Apart from initial grants following UK Inland Revenue approval of the Approved Plan, options will normally only be granted within 42 days of the announcement of Investec PLC's results to the London Stock Exchange for any period. It is not intended to grant options under the Option Plan immediately following Admission, apart from the grant of some options in connection with continuing rights under the IGL UK Share Option Plan (see paragraph 5.9 below).

The Option Plan will be operated by the directors of Investec PLC (or a duly authorised committee of the Investec PLC Board). It is intended that the operation of the Option Plan in respect of executive directors of Investec PLC will be supervised by the remuneration committee of Investec PLC, which consists entirely of non-executive directors.

(b) Eligibility

Employees and executive directors of Investec PLC and, if so designated by the directors of Investec PLC as a participating company, any subsidiary or other company, who are more than six months before their anticipated retirement date are eligible to participate in the Option Plan.

(c) Option price

The option price must be not less than the market value of the shares on the date when options are granted (and if shares are to be subscribed, must not be less than their nominal value).

Market value in relation to Investec PLC ordinary shares, means the average of the middle-market quotations (derived from the London Stock Exchange Daily Official List) over the five preceding business days, or the middle-market quotation on the immediately preceding business day, as the directors of Investec PLC may decide.

(d) Performance conditions

When granting an option, the directors of Investec PLC will make its exercise conditional on the satisfaction of appropriate conditions relating to Investec PLC's performance. These conditions must be objective and specified at the date of grant of the option and will be based on significant and sustained improvement in the underlying financial performance of Investec PLC. The directors of Investec PLC may waive or change the conditions in accordance with their terms or if any event happens which causes the directors of Investec PLC to reasonably consider that changed conditions would be a fairer measure of performance, and would be no more difficult to satisfy, or the conditions should be waived.

(e) Individual limits

Subject to a cumulative limit of 500,000 Investec PLC ordinary shares and IGL ordinary shares in total, the total market value of Investec PLC ordinary shares and IGL ordinary shares in respect of which an individual

may participate in incentive plans in any financial year is limited to the participant's annual remuneration, including salary, bonuses, commission and benefits-in-kind. "Incentive Plans" means share based employee incentive plans (including the Option Plan, the Investec PLC Share Appreciation Option Plan 2002 and share purchase type plans such as the Investec PLC Share Purchase Plan 2002) established by the Investec PLC or IGL which confer an element of benefit on the participant, but excluding "all-employee" plans and "Fintique" type plans.

This limit may be exceeded if the directors of Investec PLC determine that exceptional circumstances make it desirable that options should be granted in excess of the limit. This would enable options to be granted, for example, to recruit or retain key executives.

(f) *Exercise of options*

Options will normally be exercisable as set out below (or in accordance with a vesting schedule set at the time of grant of the option). Exercise is also subject to the satisfaction of any performance conditions and while the optionholder is employed by Investec.

Options become exercisable in tranches of 25 per cent. on each anniversary of the date of grant starting on the second and ending on the fifth anniversary. To the extent that the option has not been exercised within 90 days it will lapse in respect of the shares covered by that tranche.

Options may be exercised (subject to the satisfaction or waiver of any performance conditions) if a participant leaves employment with Investec for any reason (except for misconduct, in which case all options immediately lapse). In these circumstances, options may only be exercised to the extent and during the period set out above, unless the remuneration committee decides otherwise. If a participant dies, his options become exercisable in full (excluding any shares in respect of which the options have previously lapsed) and may be exercised by his personal representatives, irrespective of the satisfaction or waiver of any performance conditions.

Options may also generally be exercised in full (excluding any shares in respect of which the options have previously lapsed), subject to the satisfaction or waiver of any performance conditions, on a takeover, reconstruction or winding-up of Investec PLC, or if there is a demerger or other significant distribution affecting Investec PLC. If there is a change in control of Investec PLC, and in certain other circumstances, participants may, as an alternative to exercise of their options, be allowed or required to exchange their options for options over shares in the acquiring company.

(g) *Variation in share capital*

Options may be adjusted to take account of a variation in Investec PLC's share capital. In certain specific circumstances, the option price may be adjusted below the nominal value of the shares. There is also a special adjustment facility to deal with the adjustment of options in specific circumstances which may arise as a result of economic equalisation mechanics under the DLC Structure (see paragraph 6 of Annexure 1).

(h) *Schedules*

There are currently two schedules to the Option Plan, under which options can be granted on substantially the same terms as under the Option Plan, subject to certain changes which are summarised below.

- (i) The Approved Plan has been drafted to comply with the relevant UK tax legislation so that options granted under it will attract UK tax benefits. Options may be granted in respect of Investec PLC ordinary shares only.

An individual's participation in the Approved Plan is limited so that the total value of shares (as at the date of grant) under option at any one time under the Approved Plan and any other UK Inland Revenue approved discretionary share option plans established by Investec PLC, its subsidiaries or its associated companies, does not exceed £30,000.

Options under the Approved Plan become exercisable up to 20 per cent., 50 per cent. and 100 per cent. on the third, sixth and ninth anniversaries of grant respectively, and to the extent that portion is unexercised, lapse on the expiry of 90 days after each of those anniversaries.

The special adjustment facility referred to in 5.2(g) above will only apply if the UK Inland Revenue approve, or if the Approved Plan ceases to be tax-approved.

- (ii) The Discounted Share Option Plan 2002 schedule enables the remuneration committee to grant options with an option price which is less than the market value of the shares at the date of grant. This facility has been included to accommodate the grant of options over Investec PLC ordinary shares in conjunction with the option adjustments under the IGL UK Share Option Plan referred to under the section "Continuing rights under the IGL Share Scheme" at paragraph 1 above. It is not intended to grant options under the Discounted Share Option Plan 2002 as part of Investec PLC's normal share option programme.

5.3 The Investec PLC Share Appreciation Option Plan 2002 (the "Share Appreciation Plan")

The Share Appreciation Plan is based on the Investec PLC Share Option Plan 2002, but options are granted in respect of shares (including debentures) in IGL. Under the Share Appreciation Plan, instead of a right to receive shares, eligible employees are granted a right to receive a cash amount on the exercise of the option, equal to the difference between the market value of the shares in respect of which the option is exercised (calculated at the time of exercise) and the option exercise price.

5.4 The Investec PLC Sharesave Option Plan 2002 (the "Sharesave Plan")

(a) General

The Sharesave Plan has been drafted to comply with the relevant UK tax legislation so that options granted under it will attract UK tax benefits.

Under the Sharesave Plan employees are granted an option to acquire Investec PLC ordinary shares in the future at a price determined at the date of invitation or date of grant of the option. The option price may be set at a discount to market value at that time. Employees are required to save monthly through a contractual savings arrangement over a period of either three or five years. At the end of the savings contract the employee may either exercise the option using the savings contributions and interest (or an equivalent amount) or have the savings and accrued interest repaid. In the case of a five-year contract, the participant can elect to leave the savings in his account for a further two years.

(b) Operation

The directors of Investec PLC, or with the consent of the directors of Investec PLC, the trustee of an employee benefit trust, may issue invitations and grant options under the Sharesave Plan. Apart from initial invitations following UK Inland Revenue approval, invitations will normally only be issued within 42 days of the announcement of Investec PLC's results to the London Stock Exchange for any period.

(c) Eligibility

All United Kingdom based employees and full-time directors of Investec PLC and, if so designated by the directors of Investec PLC, any subsidiary or other company which the UK Inland Revenue permit, may participate in the Sharesave Plan. However, the directors of Investec PLC may set a qualifying period of continuous employment (not exceeding five years) for eligibility. When the Sharesave Plan is operated, all eligible employees must be invited to participate. Participation may also be offered to any other employees.

(d) Option price

The directors of Investec PLC set the option price, which must not be manifestly less than 80 per cent. of the market value of an Investec PLC ordinary share on the business day before the date of invitation or the average market values over the three preceding business days.

(e) Employee contributions

The maximum amount an employee may save monthly over the three-year or five-year period is the maximum allowed under a UK Inland Revenue approved savings-related share option plan, which is currently £250 per month. The minimum amount which may be saved under the Sharesave Plan is £10 per month.

(f) *Exercise of options*

Options can normally only be exercised for six months starting either three, five or seven years after the start of the savings contract. Options may, however, be exercised early in certain circumstances. These include an employee leaving employment with Investec PLC or any of its subsidiaries or associated companies, (or if permitted by UK Inland Revenue, with Investec) due to injury, disability, redundancy or retirement, or following the sale of his employing company or business. On cessation of employment for any other reason, options will normally lapse.

Options may generally be exercised early on a takeover, scheme of arrangement, merger or other corporate reorganisation, or on a winding-up of Investec PLC. Alternatively, if there is a change in control of Investec PLC, and in certain other circumstances, participants may be allowed or required to exchange their options for options over shares in the acquiring company.

(g) *Variation of share capital*

Options may be adjusted to take account of a variation in Investec PLC's share capital. In certain specific circumstances, the option price may be adjusted below the nominal value of the Investec PLC ordinary shares. Options may also be adjusted in specific circumstances which may arise as a result of economic equalisation mechanics under the DLC Structure (see paragraph 6 of Annexure I) if UK Inland Revenue so permit or the Sharesave Plan ceases to be tax-approved.

5.5 The Investec PLC Share Purchase Plan 2002 (the "Purchase Plan")

(a) *Operation*

The Purchase Plan will be operated by the directors of Investec PLC (or a duly authorised committee of the Investec PLC Board). It is intended that the operation of the Purchase Plan in respect of executive directors of Investec PLC will be supervised by the remuneration committee. It is not intended to operate the Purchase Plan immediately following Admission.

(b) *Eligibility*

The Purchase Plan offers employees and executive directors of Investec PLC and any participating subsidiaries the opportunity to buy shares and debentures in Investec PLC (both referred to as "shares" in this paragraph 5.5) at the market price at the time the offer is made. The individual limits set out in paragraph 5.2(e) apply to the Purchase Plan. Employees must not be within six months of retirement. Individual participation in the Purchase Plan is limited as described in paragraph 5.2(e) above.

(c) *Payment for the shares*

Participants are loaned the purchase price by the trustees. Interest may be charged on the outstanding loan. Participants may pay any part of the aggregate amount of such loan at any time, but must pay at least 10 per cent. of the aggregate amount of the loan by the second anniversary of the offer date and on each subsequent anniversary until the tenth anniversary when the whole amount is payable.

(d) *Holding of the shares*

The shares which the participant has agreed to buy are registered in the name of the trustee or a nominee on the participant's behalf, and are held as security against the loan made to the participant.

(e) *Rights to the shares*

The participant's rights to the shares are restricted until the shares are released in accordance with the terms of the Purchase Plan. In the meantime, the trustee has the right to vote on the shares, lend or sell or pledge the shares. Participants are not entitled to delivery of specific shares, but rather to delivery of a number of shares of a given class. Participants are entitled to dividends.

(f) *Release of the shares*

The participant becomes entitled to have the shares released in tranches of 25 per cent. on each anniversary of the offer date between the second and fifth anniversaries and, provided certain conditions are satisfied, in particular, the participant remaining in employment and repaying the appropriate part of the loan plus interest.

If a participant leaves employment with Investec due to death, retirement or for any other reason which the directors of Investec PLC, in their discretion, deem to be good and sufficient, the participant has the right to take up and pay for all the shares. Alternatively, he can force the trustee to buy the shares back from him. If a participant leaves employment with Investec in any other circumstances (including misconduct), he must repay the loan plus interest in respect of all the shares. Alternatively, the trustee can force him to sell the shares back to the trust.

(g) *Repurchase price*

The price at which the shares are repurchased by the trust is the lesser of the market value of the shares and the outstanding loan plus interest payable by the participant in respect of the purchase price.

5.6 The Investec PLC Share Participation Plan 2002 (the “SPP”)

(a) *General*

The SPP offers three ways to provide Investec PLC ordinary shares (referred to as “shares” in this paragraph 5.6) to employees – free, partnership and matching shares. The SPP contains all three elements and the directors of Investec PLC will decide which, if any, should be implemented. The SPP operates in conjunction with a trust, which will hold shares on behalf of participants. It is intended that UK Inland Revenue approval for the SPP will be sought if it is decided to operate the SPP.

(b) *Operation*

The SPP may be operated by the directors of Investec PLC (or a duly authorised committee of the Investec PLC Board). It is intended that the operation of the SPP in respect of executive directors of Investec PLC will be supervised by the Remuneration Committee.

If it is decided to offer free shares, apart from initial awards of free shares following UK Inland Revenue approval, free share awards will normally only be made within 42 days of the announcement of Investec PLC’s results to the London Stock Exchange for any period.

(c) *Eligibility*

All United Kingdom based employees and full-time executive directors of Investec PLC and any subsidiaries designated by the directors of Investec PLC as participating companies must be eligible to join the SPP. The directors of Investec PLC may set a qualifying period of continuous employment which may not exceed 18 months. Participation may also be offered to other employees who have satisfied the qualifying period of service, if any.

(d) *Free shares*

The SPP provides for the award of free shares in Investec PLC with a market value limited by the tax legislation to, currently, £3,000 for each participant each year. The free shares must generally be offered to all eligible employees on similar terms, but the number of free shares can vary by reference to the participant’s remuneration, length of service or hours worked. The directors of Investec PLC may make the awards of free shares subject to performance targets.

Free shares must generally be held in trust for between three and five years at the discretion of Investec PLC and will be free of income tax and national insurance if held in trust for five years. If a participant leaves employment with Investec PLC or any of its subsidiaries or associated companies (“the Employment Group”), or if permitted by UK Inland Revenue, with Investec, his shares cease to be subject to the SPP. The directors of Investec PLC may require free shares to be forfeited if the participant leaves the Employment Group or, if permitted by UK Inland Revenue, Investec, within three years other than through death, retirement, redundancy, injury or disability or his employing company or business being sold outside the Employment Group or, if permitted by the UK Inland Revenue, Investec.

(e) *Partnership shares*

Employees may be offered the opportunity to purchase shares out of monthly contributions taken from pre-tax salary of up to the maximum set by legislation (currently £1,500 in each tax year, or 10 per cent. of salary if less). Employees can stop saving at any stage. The employees’ contributions may be used to buy

partnership shares immediately or accumulated for up to 12 months before they are used to buy shares. Where they are accumulated the price at which they are acquired is the lesser of the price at the beginning of the accumulation period and the end.

Partnership shares can be withdrawn from the SPP by the participant at any time, but there will be an income tax and national insurance liability if the shares are withdrawn before five years.

(f) *Matching shares*

The SPP provides that where employees buy partnership shares, the directors of Investec PLC may award additional free shares on a matching basis, up to a current maximum of two matching shares for each partnership shares. Matching shares must be offered on the same basis to each participant purchasing partnership shares on each occasion. Matching shares must generally be held in trust for a minimum of three years and will be free of income tax if held in trust for five years.

The directors of Investec PLC may decide that if a participant withdraws his partnership shares within a period not exceeding three years, he will forfeit the linked matching shares. In addition, the directors of Investec PLC may decide that if the participant ceases to be employed in the Employment Group or, if permitted by the UK Inland Revenue, in Investec within three years (or within such shorter period as the directors of Investec PLC may decide) other than for a specified reason such as retirement, redundancy or disability, his matching shares will be forfeited.

(g) *Dividends*

The SPP provides that directors of Investec PLC may permit any dividends paid on the free, partnership or matching shares to be re-invested in the purchase of additional shares, which must be held in the SPP for a period of three years.

(h) *Voting rights*

Participants may direct the trustees how to exercise the voting rights attributable to the shares held on their behalf. The trustees will not exercise the voting rights unless they receive the participants' instructions.

5.7 Investec PLC employee trusts

(a) *Introduction*

Investec PLC has established the Investec PLC employee trusts to operate in conjunction with the Investec PLC employee share plans. This will provide Investec PLC with flexibility in the sourcing of shares (including debentures) to satisfy options and other rights granted under the Investec PLC employee share plans.

(b) *The Investec PLC Jersey Trust Number 1 ("Jersey Trust Number 1")*

Jersey Trust Number 1 is a Jersey resident discretionary trust for the benefit of employees and former employees of Investec PLC and its subsidiaries, together with their spouses and children under the age of 18 years. The Trustee is Theodores Trustees (Jersey) Limited (the "Trustee").

Investec PLC and its subsidiaries may fund Jersey Trust Number 1 by loan or gift to acquire shares or debentures in Investec PLC group companies, either by market purchase or by subscription. The Trustee may use the securities, for the purposes of incentive plans established or to be established by Investec PLC, or its subsidiaries for employees in the United Kingdom or overseas, such as option plans, share purchase plans and bonus plans. However, shareholder approval will be sought for any plans which constitute a "long-term incentive scheme" (as defined in the UK Listing Rules) in which directors of Investec PLC are to participate, where required by the UK Listing Rules.

(c) *The Investec PLC Jersey Trust Number 2 ("Jersey Trust Number 2")*

Investec PLC has also established Jersey Trust Number 2, which is similar in structure to Jersey Trust Number 1, but which may subscribe, acquire and hold shares or debentures in IGL group companies. In particular, the class of beneficiaries under Jersey Trust Number 2 is the same as under Jersey Trust Number 1, and the Trustee is also trustee for Jersey Trust Number 2. It is desirable to have separate trusts for United Kingdom legal reasons.

It is intended that Jersey Trust Number 2 will be used for incentive plans established by Investec PLC or its subsidiaries which are designed to deliver benefits to Investec PLC's employees, in the United Kingdom or overseas, by reference to IGL share performance, such as the Investec PLC Share Appreciation Option Plan 2002. However, shareholder approval will be sought for any plans which constitute a "long-term incentive scheme" (as defined in the UK Listing Rules) in which the directors of Investec PLC are to participate, where required by the UK Listing Rules.

(d) *Other Investec PLC employee trusts*

For Jersey tax reasons, employees resident in Jersey are excluded from the class of beneficiaries of Jersey Trust Number 1 and Jersey Trust Number 2. They are instead beneficiaries of two Guernsey resident trusts which are otherwise identical to Jersey Trust Number 1 and Jersey Trust Number 2. The trustee of those Guernsey trusts are Guinness Flight Trustees S.a.r.l.

If appropriate, Investec PLC may also establish a qualifying employee share ownership trust ("QUEST"), to operate in conjunction with the Investec PLC Sharesave Plan 2002 and any sharesave option plan established by Investec PLC or its subsidiaries.

(e) *Limits on shareholding*

Any Investec PLC ordinary shares issued to the Investec PLC employee trusts (including, if established, the QUEST) will be treated as counting towards the 10 per cent. in 10 years dilution limit referred to in paragraph 5.1 above. Similarly, any IGL ordinary shares issued to the Investec PLC employee trusts will be treated as counting towards the limit required by the JSE.

Investec PLC has obtained shareholder approval for the Investec PLC employee trusts (and any other employee trusts which Investec PLC may establish in the future) to hold a total of up to (but not including) 10 per cent. of Investec PLC's issued share capital at any one time. This limit will not be exceeded without prior shareholder approval.

5.8 Investec PLC shareholder approval

The Investec PLC employee share plans and the establishment of the Investec PLC employee trusts will all be approved by Investec PLC's shareholders on 12 July 2002. The directors of Investec PLC will thereafter adopt and establish the Investec PLC employee trusts.

5.9 Continuing rights under the IGL UK Share Option Plan (the "IGL UK Plan")

Options have been granted under the IGL UK Plan at market value to employees and full-time directors of IGL and participating companies, and are either UK Inland Revenue approved options or were granted on an unapproved basis. There are no performance conditions attaching to the options.

The options will normally be exercisable up to 25 per cent., 50 per cent., 75 per cent. and 100 per cent. on the second, third, fourth and fifth anniversary of the grant of the option respectively. All options which have not been exercised within ten years from the date on which they were granted automatically lapse. Options may be adjusted in the event of any capitalisation (other than a scrip issue), rights issue, consolidation, subdivision, reduction or other variation of the share capital of IGL, subject to the confirmation of IGL's auditors that the adjustments are fair and reasonable and, in respect of approved options, the approval of the UK Inland Revenue.

It is proposed to adjust options under the IGL UK Plan to take account of the IGL capital restructure. It is intended to reduce the number of IGL ordinary shares under option and leave the option price unchanged. This will, in respect of UK Inland Revenue approved options, be done on a tax-approved basis if the UK Inland Revenue agree. If the UK Inland Revenue do not agree, the adjustment will take place on an unapproved basis, which will result in the approved options losing their tax-approved status. The confirmation of Ernst & Young as auditors, that the proposed adjustment is, in their opinion, fair and reasonable will be obtained.

In conjunction with the adjustment mentioned above, it is intended that Investec PLC will grant new unapproved options under the Investec PLC Share Option Plan 2002 to individuals whose options are adjusted under the IGL UK Plan, in respect of the balance of the original IGL options. It is intended that the adjusted IGL options and the new options over Investec PLC ordinary shares should together be of equivalent value to the original IGL options. To reflect the terms of the original IGL options, the new Investec PLC options will have the same vesting schedule as the original IGL options, and will not be subject to performance conditions.

In addition, the IGL Board have approved the amendment of the rules of the IGL UK Plan to allow exercise by a participant while a director or employee of Investec. This will enable participants to maintain their adjusted options over IGL ordinary shares. In respect of options granted under the Approved Plan, this amendment will be done on a tax-approved basis if the UK Inland Revenue agree. If the UK Inland Revenue do not agree, the amendment will be made on an unapproved basis, which will result in the approved options losing their tax-approved status.

As at 31 May 2002, options are outstanding over 2 644 638 IGL ordinary shares under the IGL UK Plan. Following the proposed adjustment, there will be 978 516 IGL ordinary shares under option and 1 666 122 Investec PLC ordinary shares under replacement options granted under the Investec PLC Share Option Plan 2002. No further options will be granted under the IGL UK Plan.

TERMS AND CONDITIONS OF SHARES HELD IN THE NOMINEE

IGL members and Inhold members are referred to the contents of the circular of which this Annexure XVI forms part and are advised that if such members' entitlement to ordinary share(s) in IGL or Investec PLC is/are registered in the name of the nominee, the following terms and conditions shall be deemed to apply (hereinafter, for the purposes of this Annexure, IGL and Investec PLC are each referred to as "the respective company"):

1. INTERPRETATION

- 1.1 Unless otherwise expressly stated, or the context otherwise requires, the words and expressions listed below shall, when used in these terms and conditions, bear the meanings ascribed to them in the circular dated 20 June 2002 of which this Annexure XVI forms part.
- 1.2 When any number of days is prescribed such number shall exclude the first and include the last day unless the last day falls on a Saturday, Sunday, or a public holiday in South Africa, in which case the last day shall be the next succeeding day which is not a Saturday, Sunday or a public holiday in South Africa.

2. OWNERSHIP OF SHARES

- 2.1 The nominee will appear in the sub-register on the respective company's shareholders register as the holder of the shareholder's shares.
- 2.2 The nominee will keep a separate register showing how many shares it holds on behalf of the shareholder.
- 2.3 Neither the respective company nor the nominee will recognise any right claimed by a trust or any other right in respect of shares, unless such right is reflected in their respective share registers.
- 2.4 If a shareholder of the respective company wishes to give any instruction in relation to his shares, such instruction must be in the nominee's prescribed format, which format shall be made known to the shareholder of the respective company by the nominee from time to time.
- 2.5 In respect of any instruction received, the nominee may require the shareholder of the respective company to prove that he has the necessary authority to give such an instruction. The nominee shall not be obliged to carry out the instruction until the shareholder of the respective company has furnished the required proof.
- 2.6 The nominee shall not be obliged to take any action in terms of these terms and conditions which in their sole and absolute discretion is or may be contrary to any law, regulation or rule, with which rule it is obliged to comply with, or which is or may be contrary to its articles of association.

3. DIVIDENDS

- 3.1 The nominee will pay all dividends received on behalf of the shareholder from the respective company into the bank account advised to the nominee from time to time as his settlement account.
- 3.2 If the respective issuer gives its shareholders' the option to receive dividends either in the form of cash or in the form of additional shares, the nominee will notify the shareholder of such an option, and request instructions. If no instructions are received from the shareholder of the respective company, the nominee will elect the default option and in the case of shares being the default, the nominee will receive the shares and hold the shares on behalf of the shareholder of the respective company, in accordance with these terms and conditions.
- 3.3 Where applicable, exchange control legislation and regulations will require dividend payments to be made to an appropriate "blocked account".

4. ISSUE OF NEW SHARES AND OTHER OFFERS

- 4.1** If the respective company's shareholders become entitled to additional shares, which shares are to be issued without payment, the nominee will receive the shares and hold the shares on behalf of the shareholder of the respective company, in accordance with these terms and conditions.
- 4.2** If the respective company's shareholders become entitled to purchase additional shares, the nominee will notify the shareholder of the respective company of the new share issue and request instructions as to whether the shareholder wishes the nominee to exercise the option on behalf of the shareholder or not. Alternatively a shareholder of the respective company may require the nominee to assign the option to the shareholder. The nominee will hold any shares purchased by the shareholder of the respective company, unless the shareholder instructs otherwise. The shareholder of the respective company will be required to make arrangements for the necessary payment in cleared funds in order for the nominee to exercise the option or rights on the shareholder's behalf.
- 4.3** If any offer relevant to the respective company's shareholders is made, the nominee will advise such shareholder of the offer and of the courses of action available to such shareholder and will request instructions.
- 4.4** Where any other rights are offered in connection with the shares, the nominee will take all reasonable steps to ensure that the shareholder receives, as far as is practically possible, the same rights he would have received, had the shareholder held the shares in his own name.
- 4.5** If the nominee is required by the respective company, or any other person, to give warranties or to enter into any other agreement before acting for the shareholder under these terms and conditions, the nominee may require the shareholder to give similar warranties or to enter into similar agreements with it, before it agrees to act on behalf of the shareholder.
- 4.6** Where the shareholder of the respective company is asked to give instructions and he fails to do so, or fails to give the required instructions in time, the nominee will not take any action on behalf of the shareholder.

5. INFORMATION

- 5.1** The nominee will arrange for the respective company to send the shareholder of the respective company the same information it sends to all its shareholders holding shares in certificated form.
- 5.2** The nominee will send the shareholder of the respective company a regular share statement in accordance with the guidelines promulgated from time to time in regulations under the Companies Act, (Act 61 of 1973), as amended, but at least twice per annum, showing the number of shares it holds on behalf of the shareholder of the respective company, provided that the nominee may send any regular statement together with the statement advising the payment of any dividend.
- 5.3** The nominee will send the shareholder of the respective company a statement reflecting the amended number of shares it holds on behalf of the shareholder of the respective company following every purchase or sale of shares by such shareholder.

6. VOTING AT SHAREHOLDER MEETINGS

- 6.1** The nominee will send the shareholder of the respective company information about the respective company's shareholder meetings and a form on which the shareholder of the respective company can note his voting instructions or indicate his preference to attend and speak at the meeting on his own behalf.
- 6.2** The nominee will vote at the respective company's shareholders meeting in accordance with the shareholder's instructions. If a shareholder does not give any instructions or does not give instructions in time, the nominee will not vote on behalf of the shareholder of the respective company.
- 6.3** A shareholder of the respective company may attend and speak at any of the respective company's shareholders meetings as a proxy of the nominee, provided that the shareholder provides the nominee with a written request to this effect in order for the nominee to prepare the necessary letter of representation in favour of the shareholder.

7. LEAVING “THE ISSUER SPONSORED NOMINEE”

- 7.1** If a shareholder of the respective company at any time no longer wishes his shares to be held by the nominee, such shareholder may either ask to receive a share certificate in respect of the shares held or may request that such shares be transferred to another uncertificated securities account in either his own name at Computershare Custodial Services or at another CSDP or stockbroker.
- 7.2** In the event that the issuer decides to terminate the services of the nominee, the nominee will arrange for the shares to be transferred into the name of the shareholder of the respective company at the CSDP and may if so requested in writing by the shareholder of the respective company deliver a share certificate in certificated form to the shareholder free of charge, provided that any charge levied by STRATE shall be paid by the shareholder of the respective company.
- 7.3** All share certificates either requested by a shareholder of the respective company or issued as a consequence of the termination of the nominee's services, will be sent within 7 days of such request or issue, to the shareholder, address as set out in the sub-register maintained by the nominee.
- 7.4** In respect of any request by a shareholder of the respective company for share certificates such shareholder will be issued with the first share certificate free of charge, save that any charge levied by STRATE shall at all times be for such shareholder's own account. Thereafter the nominee reserves the right to charge the shareholder of the respective company for any subsequent share certificates issued.

8. CHARGES

- 8.1** Shareholders of the respective company will initially not be charged for any service described in this circular. The nominee, however, reserves the right to introduce a charge at any time for particular services not provided for in this circular. The imposition of such a fee will not be done without first giving the shareholder of the respective company notice and the option to withdraw from the nominee without charge within thirty days of receiving the notice.
- 8.2** The nominee reserves the right to charge a fee if the shares are withdrawn from the nominee in circumstances other than those referred to in clause 8.1.
- 8.3** The shareholder of the respective company will be obliged to pay any Value Added Tax and/or any other taxes due in respect of the services provided to such shareholder.

9. FAILURE TO TRACE

- 9.1** If on two or more occasions the nominee:
- 9.1.1** has sent documents to the shareholder's registered address and such documents have been returned;
 - 9.1.2** has sent dividend cheques or made any electronic payment and such cheques or payments have either been returned, have not been presented for payment or remain unpaid;
 - 9.1.3** the nominee shall, after having made reasonable enquiries to establish the shareholders of the respective company's current address, not be required to send the shareholder any further documentation or dividend cheques until the shareholder has notified the nominee of his new address.
- 9.2** If so permitted by the articles of association of the respective company:
- 9.2.1** after a twelve year period during which at least three dividends have been paid and none has been claimed, the nominee announces that it intends to sell the shareholder's shares, which announcement is made by placing an advertisement in a national newspaper and in at least one newspaper appearing in the area of the shareholder's last address on the nominee's share register; and
 - 9.2.2** for a period of three months after the advertisement appears, the nominee has not received any communication from the shareholder or any other person legally entitled to the shares; and

- 9.2.3** all other reasonable efforts to locate the shareholder of the respective company have been unsuccessful; and
- 9.2.4** the nominee has advised the JSE that it intends to sell the shareholder of the respective company's shares; and
- 9.2.5** the nominee may sell the shareholder of the respective company's shares and pay the proceeds to the respective company.

10. VARIATION AND ENFORCEMENT

- 10.1** The nominee may, on notice to the shareholder of the respective company, change these terms and conditions. Such change shall take effect 14 days after dispatch of the notice, unless such shareholder gives written notice within the 14 day period that the change is unacceptable, in which event such shareholder will be sent a share certificate recording that the shares held by the nominee on behalf of the shareholder have been transferred into the shareholder's own name in the register of shareholders of the respective company.
- 10.2** If the nominee does not or cannot enforce any of these terms and conditions, this will not affect its right to enforce any other term or condition of this Agreement or to enforce the same term on another occasion.

11. OTHER TERMS AND CONDITIONS

- 11.1** Any shareholder may apply to have their shares held by the nominee in terms of the Issuer-Sponsored Nominee programme. The nominee may, in its absolute discretion, refuse to accept any application to hold shares in the respective company on behalf of the shareholder of the respective company.
- 11.2** The nominee can employ agents on such terms as it deems fit and may delegate any discretion it may have under these terms and conditions to the agent, to the extent that such delegation is permitted by law or regulation.
- 11.3** The respective company and the nominee may, as a consequence of these terms and conditions, disclose information about the shareholder of the respective company:
 - 11.3.1** to each other or to their agents for the purposes of these terms and conditions; or
 - 11.3.2** where such disclosure is required by law or regulation.
- 11.4** All cheques, share certificates, statements and other documents sent to the shareholder of the respective company under these terms and conditions, are sent at the shareholder's own risk.
- 11.5** All payments to the shareholder of the respective company under these terms and conditions will be made after making such deductions or withholdings as are required by law or are necessary to meet any liability of the respective company or the nominee arising out of the holding of the shares by the nominee.
- 11.6** The shareholder of the respective company is responsible for obtaining all approvals that are necessary for such shareholder to hold his shares in, or to transfer them out of the nominee. If there is any inconsistency between the shareholder's rights under these terms and conditions and his rights in terms of the respective company's articles of association, the provisions of the articles of association will prevail.
- 11.7** Neither the respective company nor the nominee will be liable to the shareholder of the respective company for any loss or liability, whether direct or consequential, and the shareholder hereby indemnifies the respective company, the nominee and their respective agents, against any loss or liability suffered or incurred as a result of:
 - 11.7.1** acting on the shareholder's instructions;
 - 11.7.2** the failure of the shareholder of the respective company to give instructions;
 - 11.7.3** late instructions from the shareholder of the respective company;
 - 11.7.4** the nominee following the terms of these terms and conditions;
 - 11.7.5** the respective company, the nominee or any person acting on behalf of the shareholder of the respective company, being unable to perform any of the services under these terms and conditions due to circumstances beyond its reasonable control.
- 11.8** These terms and conditions and all obligations thereunder are binding on all successors, executors, administrators and other legal representatives.

12. NOTICES

12.1 Each party chooses as its address for all purposes under these terms and conditions ("chosen address"), whether for serving any court process or documents, giving any notice, or making any other communications of whatsoever nature and for any other purpose arising from these terms and conditions ("notice"), as follows:

The nominee 3rd Floor, Edura, 41 Fox Street, Johannesburg, 2001;

The shareholder the address from time to time registered in the share register of the respective company maintained by the nominee.

12.2 Any notice required or permitted under these terms and conditions shall be valid and effective only if in writing.

12.3 Any party may by notice to the other party change its chosen address to another physical address in the Republic of South Africa and such change shall take effect on the seventh day after the date of receipt by the party who last receives the notice.

12.4 Any notice to a party contained in a correctly addressed envelope and:

12.4.1 sent by prepaid registered post to it at its chosen address; or

12.4.2 delivered by hand to a responsible person during ordinary business hours at its chosen address, shall be deemed to have been received, in the case of 12.4.1, on the seventh business day after posting (unless the contrary is proved) and, in the case of 12.4.2, on the date of delivery.

12.5 Notwithstanding anything to the contrary herein, a written notice actually received by a party, including a notice sent by telefax ("the first notice"), shall be an adequate notice to it notwithstanding that it was not sent or delivered to its chosen address, provided that, within the next three succeeding business days, a copy of the first notice is delivered to the chosen address, accompanied by a notice giving the following particulars:

12.5.1 where the first notice was sent by telefax, the date and time of despatch and the telefax number to which it was sent; and

12.5.2 where the first notice was delivered in a manner other than by telefax, the manner of delivery, the date on which it was delivered, the person by whom it was received and where it was received.

13. GENERAL

13.1 These terms and conditions constitute the sole record of the agreement between the parties with regard to the subject matter hereof. No party shall be bound by any express or implied term, representation, warranty, promise or the like not recorded in these terms and conditions.

13.2 No addition to, variation of, or agreed cancellation of, these terms and conditions shall be of any force or effect unless in writing.

13.3 No relaxation or indulgence which any party may grant to any other shall constitute a waiver of the rights of that party and shall not preclude that party from exercising any rights which may have arisen in the past or which might arise in future.

13.4 Any provision of these terms and conditions which contemplates performance or observance subsequent to any termination or expiration of these terms and conditions shall survive any termination or expiration of these terms and conditions and continue in full force and effect.

13.5 Unless expressly provided as being in the sole discretion of a party, where approval, acceptance, consent or similar action by a party is required under these terms and conditions, such action shall not be unreasonably delayed or withheld. An approval or consent given by a party under these terms and conditions shall only be valid if in writing and shall not relieve the other party from responsibility for complying with the requirements of these terms and conditions nor shall it be construed as a waiver of any rights under these terms and conditions except as and to the extent otherwise expressly provided in such approval or consent, or elsewhere in these terms and conditions.

TERMS AND CONDITIONS OF THE CUSTODY AGREEMENT

IGL members and Inhold members are referred to the contents of the circular of which this Annexure XVII forms part and are advised that the following terms and conditions shall be deemed to apply should they appoint Computershare Custodial as their CSDP:

I. INTERPRETATION

- 1.1** Unless otherwise expressly stated, or the context otherwise requires, the words and expressions listed below shall, when used in this Agreement, bear the meanings ascribed to them:
- 1.1.1** "Agreement" means this private investor custody and settlement agreement between the Client and Computershare;
 - 1.1.2** "Client" means the contracting natural person or juristic person identified in Part A of the applicable surrender forms;
 - 1.1.3** "Issuer-Sponsored Nominee" means the nominee company appointed by an issuer of securities to hold securities in the Issuer on behalf of its holders of securities;
 - 1.1.4** "Bank Account" means the Clients' nominated bank account detailed in Part B of the applicable surrender form or as may be amended and advised in writing to Computershare from time to time;
 - 1.1.5** "Computershare" means Computershare Custodial Services Limited (registration number 2000/006082/06);
 - 1.1.6** "Custody Act" means the Custody and Administration of Securities Act (Act 85 of 1992) as amended;
 - 1.1.7** "JSE" means the JSE Securities Exchange South Africa;
 - 1.1.8** "Securities" means securities as defined from time to time in the Custody Act;
 - 1.1.9** "Securities Legislation" means the Companies Act (Act 61 of 1973) as amended, the Custody Act, the Rules and Directives of the JSE or any other applicable stock exchange and the Rules and Directives of any central securities depository made under section 12(2) of the Custody Act.
- 1.2** Clause and paragraph headings are for purposes of reference only and shall not be used in interpretation.
- 1.3** Unless the context clearly indicates a contrary intention, any word connoting any gender includes the other two genders, the singular includes the plural and *vice versa* and natural persons includes artificial persons and *vice versa*;
- 1.4** When any number of days is prescribed such number shall exclude the first and include the last day unless the last day falls on a Saturday, Sunday, or a public holiday in the Republic of South Africa, in which case the last day shall be the next succeeding day which is not a Saturday, Sunday or a public holiday in the Republic of South Africa.

2. APPOINTMENT

- 2.1** Subject to the terms of this Agreement, the Client appoints Computershare as its agent, custodian and administrator for the safe keeping and administration of securities, and for the settlement of transactions in those securities and to attend to certain incidental matters detailed in this Agreement.
- 2.2** The parties shall at all times be bound by the provisions of the Securities Legislation.

3. SECURITIES DEPOSITED FOR SAFE CUSTODY

- 3.1** Securities that Computershare may accept on behalf of the Client in accordance with this Agreement shall be securities of a type and form determined from time to time by Computershare and may include either certificated or uncertificated securities.
- 3.2** Computershare shall not be obliged to accept any security remitted in terms of this Agreement. In the event that any security remitted for entry into a Securities Account is not good for delivery or has a defect in relation to the Client's title thereto, Computershare shall not accept such security for entry into a Securities Account until such defect has been corrected to the satisfaction of Computershare. Computershare shall return to the Client any securities not accepted by Computershare in accordance with this Agreement or the Securities Legislation.
- 3.3** The Client warrants to Computershare that the Securities deposited for safe custody from time to time will be and remain free from any charge or other encumbrance, other than as provided for in this Agreement.

4. CONFLICT

In the event of any conflict between the provisions of this Agreement and the Securities Legislation, the provisions of the Securities Legislation shall prevail.

5. SECURITIES ACCOUNT

- 5.1** Computershare shall in accordance with its standard operating procedures open and maintain a securities account(s) in its records in the name of the Client or his duly designated nominee to record the number or nominal value of securities of each kind deposited by the Client with Computershare and to record all transactions and entries made in respect of such securities ("the Securities Account").
- 5.2** Any entry made in a Securities Account shall be made only in accordance with authenticated instructions given by the Client and the provisions of the Securities Legislation.
- 5.3** Computershare shall not be obliged to make any entry in a Securities Account unless it conforms to clause 9 (nine) of this Agreement.
- 5.4** Computershare shall not give effect to any instruction that will result in a debit balance in respect of any security held in a Securities Account.

6. SAFEKEEPING OF SECURITIES

- 6.1** Records of uncertificated securities held by Computershare shall be kept and maintained in the manner provided for in the Securities Legislation.
- 6.2** Securities held by Computershare shall at all times be held in accordance with the election detailed in Part D of the applicable surrender form. Any Security held under an issuer-sponsored nominee program shall be subject to the terms and conditions from time to time under which such issuer-sponsored nominee program is administered, and the Client shall by instructing Computershare to register securities using this service be deemed thereby to agree to such terms and conditions.
- 6.3** Computershare shall take such steps to protect securities held under custody against theft, loss or destruction as provided for in the Custody Act.

7. SETTLEMENT OF TRANSACTIONS

- 7.1** The Client shall designate a current banking account at a registered bank as a settlement account for the purposes of this Agreement. The Client designates the bank account indicated in Part B of the applicable surrender form as the settlement account. The designated bank account may be amended from time to time by completing the necessary instruction in writing to Computershare.

- 7.2** Computershare shall credit the designated bank account with all proceeds received by Computershare in respect of the securities held in or transacted through the Securities Account. The Client authorises Computershare or its agent to debit the designated bank account with any amount owing by the Client.
- 7.3** Notwithstanding the provisions of paragraph 7.1, the Client shall ensure that in respect of any purchase of securities by the Client in respect of which Computershare is required to act as settlement agent, the Client shall immediately upon acceptance of the purchase order deposit cleared funds to cover the purchase consideration to the **Computershare Custodial Services Ltd – Client Trust Account**, being account number **62022148151** held at **First National Bank**, branch code **25-50-05**. The Client acknowledges that he is conversant with his responsibility to provide settlement instructions to Computershare in accordance with the provisions from time to time of Directive E of the JSE Rules.
- 7.4** Unless settlement instructions and cleared funds are received by Computershare in accordance with Clause 7.3, Computershare shall not be under any obligation to confirm settlement to a central securities depository and the Client shall be liable for any resultant penalties levied by a settlement authority pursuant to any failed trade.

8. SECURITIES STATEMENTS

- 8.1** Computershare shall provide the Client with periodic statements reflecting all entries in the Securities Account and the applicable bank accounts during the relevant period.
- 8.2** Unless an objection is made in writing by the Client to any entry contained in any statement of a Securities Account within 60 days after the statement date, the statement shall, in the absence of fraud or any manifest error, be treated as *prima facie* evidence of the entries indicated therein and the Client shall not thereafter be entitled to make any claim against Computershare or to any other action in respect thereof.

9. INSTRUCTIONS BY THE CLIENT

- 9.1** All instructions given by the Client shall be sent to Computershare at the address set out at clause 14 of this Agreement. All instructions shall be sent in writing, by such means as may be approved by Computershare from time to time in writing. Computershare shall not be obliged to carry out any instruction that does not comply with this Agreement, the Securities Legislation or Computershare's standard operating procedures.
- 9.2** On each occasion on which an instruction is given, the Client will be regarded as having confirmed that he has the necessary authority. Computershare may record telephonic or electronic conversations with the Client and its representatives and the Client agrees that such recordings or transcripts thereof may be used as evidence in any dispute with the Client.
- 9.3** In the event that the Client gives to Computershare an instruction to buy or sell securities on behalf of the Client, subject to the limited mandate to carry out such instruction without having to exercise any independent discretion and in terms of a particular service offered by Computershare, then the Client gives to Computershare the right to appoint and pay brokers and other agents to carry out such instruction, to receive and give receipts in respect of such purchases or sales and to do all such things incidental thereto in order to give effect to such instruction.

10. DEALING ROUTING SERVICE

- 10.1** By submitting any instruction to transact in securities using the Computershare Dealing Routing Service ("dealing service") the Client agrees to the following provisions:
- 10.2** The Client may only give instructions to transact in any security in writing or by means of the telephonic service when operational. Instructions will not be accepted by any other means, including without limitation, fax, electronic mail, and photocopied forms or through the Internet. Computershare reserves the right to alter the times that the telephonic service is available.
- 10.3** Computershare will not carry out any instruction to transact securities on behalf of the Client unless it is satisfied that the Client has been recorded as the owner of the securities in Computershare's records.

- 10.4** The Client may only use the dealing service if his securities are registered in the South African sub-register maintained and operated by Computershare.
- 10.5** Computershare will endeavor to inform the Client if an instruction given by the Client will not be carried out unless Computershare has good reason for not doing so. Computershare will not be liable for refusing to carry out any instruction if it has good reason for not doing so.
- 10.6** Any instruction submitted by another person on behalf of the Client should not be recognised unless an original power of attorney or other appropriate authority (or a complete copy thereof certified by a Commissioner of Oaths) has been received and accepted by Computershare.
- 10.7** All instructions given by the Client to the dealing service are irrevocable and shall be dealt with on the business day immediately following the business day on which they were received and failing that as soon as reasonably possible thereafter:
- 10.8** No limit order or raise order will be accepted by Computershare. The Client acknowledges that prices may fluctuate from the time the instruction is given until the time that the transaction is executed.
- 10.9** By submitting an instruction to Computershare to arrange to sell any security on his behalf, the Client warrants that –
- 10.9.1** he has not sold or purported to sell the securities or the interest in any security to any third party;
 - 10.9.2** the securities will be sold free from all liens, charges or other third party rights or any encumbrance of any kind;
 - 10.9.3** he is entitled to sell the securities;
 - 10.9.4** the sale will not constitute a breach by the Client of any applicable laws and regulations; and
 - 10.9.5** he is not a minor, or if he is a minor, that he is properly assisted by a parent or court appointed guardian.
- 10.10** The Client irrevocably undertakes that he will do, or procure to be done, all acts and things, and execute or procure the execution of all such documents as Computershare may from time to time require to give effect to any instruction by the Client.
- 10.11** The Dealing Service shall be operated strictly on an “execution only” basis. Computershare shall not provide, or have any responsibility to or provide any financial, taxation or other advice to the Client.
- 10.12** A transaction in any security through the dealing service will be executed by a stockbroker appointed by Computershare. By submitting an instruction to Computershare the Client irrevocably authorises Computershare to appoint a stockbroker to execute the transaction on behalf of the Client on the basis that –
- 10.12.1** Computershare will instruct a stockbroker to obtain the best price reasonably available in the market at the time of dealing. If no such price can be ascertained, the stockbroker will take reasonable care to carry out the instruction at a price which is fair and reasonable; and
 - 10.12.2** Computershare shall, to the exclusion of all others including the Client, be entitled to bring any action, suit or proceedings (“Actions”) against the stockbroker arising out of or in connection with the sale. Computershare shall, in its sole discretion, determine the nature and scope of such Actions. By submitting an instruction to Computershare the Client waives his right in relation to such Actions.
- 10.13** The stockbroker appointed by Computershare may aggregate any instruction with those of other holders of securities transacting securities through the dealing service but may not aggregate the sale with any other clients of the stockbroker, provided that any aggregation shall take place in accordance with the Rules of the JSE.
- 10.13.1** The price per security that the Client will receive in the case of transactions that are aggregated will be the total proceeds of all aggregated transactions in the relevant period less all costs of the transactions divided by the number of securities sold in such transactions;
 - 10.13.2** The price per security that the Client will receive where transactions are not aggregated will be the price at which such security is sold in the relevant period less all costs of the sale;

- 10.13.3** The proceeds payable to the Client shall be rounded down, where necessary, to the nearest whole Rand. Resulting fractions of any Rand will be aggregated and may be retained by Computershare.
- 10.13.4** Each security aggregated with other security being transacted through the dealing service in any relevant period will only be treated as sold when it is actually sold by the dealing service.
- 10.14** Orders executed through the dealing service shall be subject to the charges published from time to time, initially as set out in Schedule A to this Agreement (refer to Annexure XVIII to this circular).
- 10.15** Computershare may vary the amount, rate or basis of charges from time to time and may introduce new charges.
- 10.16** Fees, taxes, charges and other expenses of whatever nature incurred on behalf of the Client will be deducted from the proceeds of any transaction.
- 10.17** Instructions to carry out more than one transaction will be treated as separate transactions and each such transaction shall be charged separately.
- 10.18** All transactions will take place on the JSE.
- 10.19** Computershare will subject to applicable exchange control legislation and regulations, pay to the Client the proceeds of any sale in accordance with the Client's instructions detailed in Part B of the applicable surrender form.
- 10.20** Advice of any transaction will be included in a transaction statement sent to the Client.
- 10.21** Computershare may terminate the dealing service at any time without giving notice thereof to the Client. All valid instructions given to the dealing service in accordance with this Agreement before termination will be carried out.
- 10.22** Transactions will be carried out and records relating to instructions by the Client will be kept according to the rules, customs and practices of the JSE.
- 10.23** If the dealing service cannot perform any of its services under this Agreement due to circumstances beyond its reasonable control, Computershare will take all reasonable steps to bring such circumstances to an end, but Computershare shall not be liable for any non-performance of the dealing service.
- 10.24** Without prejudice to any stockbroker's obligations to execute transactions on the JSE, when a stockbroker executes an instruction given to the dealing service the Client acknowledges that the stockbroker could be acting as principal for its own account. By submitting an instruction to the dealing service the Client consents, where applicable, to the stockbroker acting as principal for its own account.
- 10.25** The Client indemnifies Computershare and those persons acting on his behalf in relation to the provision of the dealing service and their respective directors, employees and agents against any liability (except to the extent that the liability is caused by Computershare or such persons' own default, negligence or fraud) which it or they may incur as a result of the Dealing Service.

II. CHARGES

- 11.1** The Client shall pay the fees and charges published from time to time by Computershare and notified to the Client.
- 11.2** Computershare may increase or vary the charges on 60 days written notice to the Client and may thereafter levy such fees or charges.
- 11.3** Notwithstanding anything to the contrary in this Agreement, Computershare shall not be obliged to act upon any instruction given by the Client or to deliver to the Client any securities or monies until all the amounts due and owing by the Client to Computershare have been discharged in full.

12. INDEMNITY

- 12.1** The Client hereby indemnifies and agrees to hold Computershare harmless against all liability, costs or expenses incurred by Computershare or its nominees or agents in connection with the due and proper performance by Computershare of its obligations pursuant to this Agreement.
- 12.2** The Client accepts the risk of loss or damage arising directly or indirectly as a result of any failure in, misuse of, or any fraud or misrepresentation due to his not giving a valid instruction in accordance with the terms of this Agreement.

13. TERMINATION

Either party may terminate this Agreement at any time by giving to the other party at least 30 days' written notice of termination to the other party.

14. NOTICES

- 14.1** The Client chooses the physical address detailed in Part A of the applicable surrender form or such amendment thereto as advised in writing to Computershare from time to time as the address for the receipt of all notices and legal process. Any notice by Computershare to the Client shall, if sent by facsimile or by e-mail, be deemed to have been received by the Client on the day of transmission of the facsimile or e-mail and if sent by post, on the seventh day after posting.
- 14.2** Any notices by Computershare to the client given either orally or by electronic means shall be deemed to have been received by the client.
- 14.3** Computershare chooses as the address for the receipt of all notices and legal process 2nd Floor, Edura, 41 Fox Street, Johannesburg 2001.

15. VARIATION

No addition to, variation or consensual cancellation of this Agreement shall be of any force or effect unless in writing and signed by or on behalf of both parties.

16. GOVERNING LAW

This Agreement shall be construed in accordance with the laws of the Republic of South Africa.

SERVICE AND SETTLEMENT FEES OF COMPUTERSHARE CUSTODIAL SERVICES LIMITED FOR MEMBERS

Inhold members and IGL members are referred to the contents of the circular of which this Annexure XVIII forms part and are advised that the following services and settlement fees of Computershare Custodial will apply to member should they elect to appoint Computershare Custodial as their CSDP:

As from 1 June 2002

Fee description	Issuer-sponsored Nominee Programme (using Computershare Dealing Service)	Computershare Nominee Service	Own Name Custody Service
Dematerialisation fee	Not applicable.*	Not applicable.*	Not applicable.*
Service fee	Not applicable.*	0,005% per annum (excluding VAT) on average daily market value of securities portfolio under administration with a minimum of R200.00 + R28.00 (VAT) = R228.00 per month.	Private Investors (natural persons) – Not applicable.* Other shareholders – 0,005% per annum (excluding VAT) on average daily market value of securities portfolio under administration with a minimum of R200.00 + R28.00 (VAT) = R228.00 per year payable in advance.
Transaction and settlement fee	Not applicable.*	On Exchange: R60.00 + R8.40 (VAT) = R68.40 per transaction. Off Exchange: R80.00 + R11.20 (VAT) = R91.20 per transaction.	On Exchange: R60.00 + R8.40 (VAT) = R68.40 per transaction. Off Exchange: R80.00 + R11.20 (VAT) = R91.20 per transaction.
Dealing fee	R0 to R25 000 = R90.00 + R12.60 (VAT) = R102.60 R25 000.01 to R50 000 = R130.00 + R18.20 (VAT) = R148.20 R50 000.01 to R100 000 = R200.00 + R28.00 (VAT) = R228.00 R100 000.01 + = 0,25% max R500 + R70.00 (VAT) = R570.00 These fees exclude any tax and STRATE transaction cost.	No Computershare fee. (The Client pays the fee agreed with his stockbroker.)	No Computershare fee. (The Client pays the fee agreed with his stockbroker.)
Issuing payments by cheque rather than electronic transfer	R20.00 + R2.80 (VAT) = R22.80.	Not applicable.	R20.00 + R2.80 (VAT) = R22.80.
Certificate withdrawal fee (Rematerialisation)	No Computershare charge for the first certificate. (However, STRATE fee of R200.00 + R28.00 (VAT) = R228.00 per certificate is payable). Thereafter R250.00 + R35.00 (VAT) = R285.00 per certificate.	No Computershare charge for the first certificate. (However, STRATE fee of R200.00 + R28.00 (VAT) = R228.00 per certificate is payable.) Thereafter R250.00 + R35.00 (VAT) = R285.00 per certificate.	No Computershare charge for the first certificate. (However, STRATE fee of R200.00 + R28.00 (VAT) = R228.00 per certificate is payable.) Thereafter R250.00 + R35.00 (VAT) = R285.00 per certificate.
Transfer holdings to broker or other CSDP	R50.00 + R7.00 (VAT) = R57.00		

*Fees sponsored by the issuer of the security.

All fees quoted, unless otherwise indicated, include any STRATE processing or transaction costs.

DEFINITIONS

“Act”	the Companies Act, 1973 (Act 61 of 1973), as amended;
“Action”	any distribution or any action affecting the amount or nature of or economic benefit derived from issued equity share capital, including any cash dividend, distribution <i>in specie</i> , offer by way of rights, bonus issue or capitalisation issue, repayment or reduction of capital, sub-division or consolidation, share buy-back or amendment of the rights of any shares or a series of one or more of such actions, but excluding any change in the Equalisation Ratio;
“Admission”	the admission of the Investec PLC ordinary shares to the Official List becoming effective in accordance with the UK Listing Rules and admission of the Investec PLC ordinary shares to trading on the London Stock Exchange;
“Applicable Regulation”	<p>(a) applicable law and regulations (including, without limitation, the requirements of the UK City Code and the SRP Code); and</p> <p>(b) directives, notices or requirements of any Governmental Agency having jurisdiction over IGL or Investec PLC, as the case may be; and</p> <p>(c) the rules, regulations, and guidelines of:</p> <p>(i) any stock exchange on which either the Investec PLC ordinary shares or the IGL ordinary shares are listed or quoted;</p> <p>(ii) any other body with which entities with securities listed or quoted on such exchanges customarily comply,</p> <p>(but, if not having the force of law, only if compliance with such directives, notices, requirements, rules, regulations or guidelines is in accordance with the general practice of persons to whom they are intended to apply) in each case for the time being in force and taking account of all exemptions, waivers or variations from time to time applicable (in particular situations or generally) to Investec PLC or, as the case may be, to IGL;</p>
“best endeavours”	in relation to an obligation of either Investec PLC or IGL, a requirement for such company to do all such things as are or may be necessary or desirable so as to comply with satisfaction of that obligation unless the companies agree that it is not reasonable to take the action or assume the obligation;
“Boards of Investec PLC and IGL” or “Boards”	the IGL Board and the Investec PLC Board and/or, in either case, a duly constituted committee thereof;
“BSE”	the Botswana Stock Exchange;
“certificated IGL members”	IGL members who hold paper share certificates;
“certificated Inhold members”	Inhold members who hold paper share certificates;
“this circular”	this circular to Inhold members and IGL members dated 20 June 2002, including the annexures hereto, the notice of the Inhold general meeting, the notice of the IGL general meeting, the forms of proxy and the forms of surrender;
“Class Rights Actions”	as described in paragraph 2.5 of Annexure I;
“common monetary area”	collectively, South Africa, the Republic of Namibia and the Kingdoms of Lesotho and Swaziland;
“Computershare Custodial”	Computershare Custodial Services Limited (registration number 2000/006082/06);

“Conversion Date”	the time and date of the Conversion Event;
“Conversion Event”	as described in paragraph 12 of Annexure I;
“CSDP”	Central Securities Depository Participant acting as custodian to shareholders under the STRATE environment;
“custody terms and conditions”	the terms and conditions set out in Annexure XVII to this circular;
“dematerialised Inhold members”	Inhold members who have replaced paper share certificates with electronic records of ownership;
“dematerialised IGL members”	IGL members who have replaced paper share certificates with electronic records of ownership;
“Dividend Access Shares”	in relation to IGL, the SA DAN Share and the SA DAS Share and in relation to Investec PLC, the UK DAN Share and the UK DAS Share;
“Dividend Access Trust Deeds”	the SA DAN Share Trust Deed, the SA DAS Share Trust Deed, the UK DAN Share Trust Deed and the UK DAS Share Trust Deed;
“DLC”	Dual Listed Companies;
“DLC Agreements”	the Sharing Agreement; the Voting Agreement; the Dividend Access Trust Deeds and the Special Converting Shares Trust Deeds; as more fully described in Annexure I and, in each case, substantially in the form submitted to the IGL general meeting;
“DLC Equalisation Principles”	the principles described in paragraph 6.1 of Annexure I;
“DLC Structure”	the arrangement whereby, <i>inter alia</i> , IGL and Investec PLC agree to operate as a single corporate group with each company observing the DLC Structure Principles in accordance with the provisions of the Sharing Agreement;
“DLC Structure Principles”	the principles which are essential to the implementation, management and operation of the DLC Structure, and which are described in paragraph 4 of Annexure I;
“Equalisation Fraction”	the Equalisation Ratio expressed as a fraction with the numerator being the number relating to the IGL ordinary shares and the denominator being the number relating to the Investec PLC ordinary shares;
“Equalisation Ratio”	as described in paragraph 2.4 of Annexure I;
“Equalisation Share”	as described in paragraph 7.5 of Annexure I;
“EXCON”	the South African Reserve Bank Exchange Control Department;
“Fintique II”	the Investec Group Limited Fintique II Scheme;
“Fintique III”	the Investec Group Limited Fintique III Scheme;
“FSA”	the UK Financial Services Authority;
“FSMA”	the United Kingdom Financial Services and Markets Act 2000;
“Governmental Agency”	any government or representative of a government or any governmental, semi-governmental, supra-national, provincial, statutory, administrative, fiscal, regulatory or judicial body, department, commission, authority, tribunal, agency or entity or trade agency, and will include, without limitation, competition authorities, the UK Takeover Panel, the London Stock Exchange, the FSA (including the UK Listing Authority), SARB, the South African Financial Services Board, the JSE, and the SRP;
“IGL” or “the company”	Investec Group Limited (registration number 1925/002833/06), a public company registered in South Africa and listed on the JSE, the BSE and the NSX;
“IGL Articles”	the new articles of association of IGL to be adopted by a resolution of IGL members at the IGL general meeting;

"IGL Board"	the board of directors of IGL from time to time;
"IGL capital reduction"	the cancellation of 89 944 500 000 IGL ordinary shares of 0,1 cent each in the authorised share capital of IGL and the cancellation of 62 230 295 772 IGL ordinary shares of 0.1 cent each in the issued share capital of IGL after the IGL share split by means of a reduction of share capital of IGL and a transfer to reserves without a distribution to shareholders;
"IGL capital restructure"	collectively, the IGL share split and the IGL capital reduction;
"IGL convertible preference shares"	class "A" variable rate compulsorily convertible non-cumulative preference shares of 60 cents each in the issued share capital of IGL;
"IGL convertible preference shareholders"	holders of IGL convertible preference shares;
"IGL distribution"	the distribution of the Investec PLC ordinary shares in terms of the IGL unbundling to IGL members registered as such on the record date for the IGL unbundling;
"IGL employee ownership schemes"	Fintique II, Fintique III, IGL share scheme and the IGL 2002 share scheme;
"IGL Equivalent Number"	in relation to IGL Special Converting Shares, such number as equals the number of Investec PLC ordinary shares then in issue divided by the Equalisation Fraction then applicable;
"IGL general meeting"	the general meeting of IGL members to be held at 09:30, or as soon thereafter as the Inhold general meeting is concluded, on Friday, 12 July 2002 in the Auditorium of Investec Bank Limited, Ground Floor, 100 Grayston Drive, Sandown, Sandton, 2196, for the purposes of approving, with or without modification, the resolutions required to implement, <i>inter alia</i> , the IGL internal restructure, the IGL capital restructure, the IGL unbundling, the implementation of the DLC Structure and the proposed Investec PLC capital raising;
"IGL group"	IGL, its subsidiary companies and associated undertakings from time to time;
"IGL internal restructure"	the intra-group disposal by IGL of the PLC operations to Investec PLC;
"IGL internal restructure agreements"	the agreements to be entered into by IGL and Investec PLC to give effect to the IGL internal restructure;
"IGL Memorandum"	the memorandum of association of IGL to be adopted by a resolution of IGL members at the IGL general meeting;
"IGL Memorandum and Articles"	the IGL Memorandum and the IGL Articles;
"IGL members"	IGL convertible preference shareholders and IGL shareholders;
"IGL ordinary shares"	ordinary shares of 60 cents each in the issued share capital of IGL before the IGL capital restructure or of 0,1 cent each after the IGL capital restructure, as the case may be;
"IGL reorganisation"	the reorganisation of IGL as described in paragraph 4.2 of this circular;
"IGL share scheme"	the Investec Group Limited Security and Purchase Option Scheme, as amended;
"IGL shareholders"	registered holders of IGL ordinary shares;
"IGL share split"	the proposed subdivision and conversion of each IGL ordinary share into 600 ordinary shares of 0,1 cent each as at the record date for the IGL capital restructure
"IGL Special Converting Shares"	as described in paragraph 2.5 of Annexure 1;
"IGL Special Converting Shares Trust Deed"	the declaration of trust to be entered into by Investec PLC, IGL and SA Trust Co which sets out the parties' rights and obligations in relation to the IGL Special Converting Shares;

“IGL 2002 scheme”	IGL Security Purchase and Option Scheme 2002;
“IGL qualifying member”	IGL members registered as such on the record date for IGL unbundling;
“IGL unbundling”	the distribution by IGL 65 382 130 Investec PLC ordinary shares to IGL members registered as such on the record date for the IGL unbundling in terms of the unbundling legislation;
“Income Tax Act”	the South African Income Tax Act, 1962 (Act 58 of 1962), as amended;
“Inhold”	Investec Holdings Limited (registration number 1985/005574/06), a public company registered in South Africa and listed on the JSE;
“Inhold delisting”	the delisting of Inhold from the JSE with effect from the commencement of business (09:00) on Friday, 26 July 2002;
“Inhold distribution”	the distribution of the IGL ordinary shares held by Inhold subsequent to the Inhold reorganisation in terms of the Inhold unbundling, to Inhold members registered as such on the record date for the Inhold unbundling;
“Inhold general meeting”	the general meeting of Inhold members to be held at 09:00 on Friday, 12 July 2002 in the Auditorium of Investec Bank Limited, Ground Floor, 100 Grayston Drive, Sandown, Sandton, 2196, for the purposes of approving, with or without modification, the resolutions required to implement, <i>inter alia</i> , the Inhold unbundling, the Inhold delisting and the Inhold winding-up;
“Inhold members”	registered holders of Inhold ordinary shares;
“Inhold reorganisation”	the reorganisation of Inhold as described in paragraph 4.1.1 of this circular;
“Inhold ordinary shares”	ordinary shares of 10 cents each in the issued share capital of Inhold;
“Inhold unbundling”	the distribution by Inhold of its entire holding of IGL ordinary shares subsequent to the Inhold reorganisation to Inhold members registered as such on the record date for the Inhold unbundling in terms of the unbundling legislation;
“Inhold winding-up”	the members' voluntary winding-up of Inhold in terms of sections 349 and 350 of the Act subsequent to the Inhold delisting;
“Insolvency Event”	in relation to any person (the “Insolvent Party”), any of the following events: <ul style="list-style-type: none"> (a) a provisional liquidator is appointed to the Insolvent Party; (b) except to reconstruct or amalgamate while solvent on terms approved by the other party, the Insolvent Party enters into a scheme of arrangement, or composition with, or assignment for the benefit of its creditors generally; (c) an administration order is made in respect of the Insolvent Party or a receiver is appointed in relation to the whole or substantially the whole of the property, assets or undertaking of the Insolvent Party; (d) the appointment of a curator to the Insolvent Party pursuant to Section 69(1)(a) of the Banks Act of South Africa (No. 94 of 1990); and (e) anything analogous or having a substantially similar effect to any of the events specified above happens under the requirements of Applicable Regulation;
“Investec” or “Group”	Investec PLC and IGL and, where the context requires, their subsidiaries and subsidiary undertakings and their associated undertakings or any of them, as the case may be;
“Investec Bank”	Investec Bank Limited (registration number 1969/004763/06), a public company registered in South Africa and a wholly-owned subsidiary of IGL;

“Investec Bank ordinary shares”	ordinary shares of 50 cents each in Investec Bank;
“Inhold qualifying member”	Inhold members registered as such on the record date for the Inhold unbundling;
“Investec PLC”	Investec PLC (registration number 3633621), a company incorporated in England and Wales under the UK Companies Act and, at the date of this circular, a wholly-owned subsidiary of IGL;
“Investec PLC Articles”	the articles of association of Investec PLC to be adopted by special resolution of the Investec PLC shareholders on or about 5 July 2002;
“Investec PLC Board”	the board of directors of Investec PLC from time to time;
“Investec PLC capital raising”	the proposed capital raising by Investec PLC by way of an issue of up to 10 million Investec PLC ordinary shares, as set out in paragraph 4.9 of this circular;
“Investec PLC ordinary shares”	ordinary shares of £0.001 each in Investec PLC;
“Investec PLC employee share plans”	the Investec PLC Share Option Plan 2002 (including schedules for the Approved Share Option Plan 2002 and the Discounted Option Plan 2002), the Investec PLC Sharesave Option Plan 2002, the Investec PLC Share Purchase Plan 2002, the Investec PLC Share Participation Plan and the Investec PLC Share Appreciation Option Plan 2002 as detailed in Annexure XV to this circular;
“Investec PLC employee trusts”	the Investec PLC Jersey Trust Number 1, the Investec PLC Jersey Trust Number 2, the Investec PLC Guernsey Trust Number 1 and the Investec PLC Guernsey Trust Number 2 as detailed in Annexure XV to this circular;
“Investec PLC Equivalent Number”	in relation to Investec PLC Special Converting Shares, such number as equals the number of IGL ordinary shares then in issue multiplied by the Equalisation Fraction then applicable;
“Investec PLC group”	Investec PLC and its subsidiary undertakings from time to time;
“Investec PLC Memorandum”	the memorandum of association of Investec PLC to be adopted by special resolution of the Investec PLC shareholders on or about 5 July 2002;
“Investec PLC Memorandum and Articles”	the Investec PLC Memorandum and the Investec PLC Articles;
“Investec PLC shareholders”	holders of Investec PLC ordinary shares from time to time;
“Investec PLC Special Converting Shares”	the special converting shares in the capital of Investec PLC to be issued to UK Trust Co having the rights set out in the Investec PLC Articles;
“Investec PLC Special Converting Shares Trust Deed”	the declaration of trust to be entered into between Investec PLC, IGL and UK Trust Co which sets out the parties' rights and obligations in relation to the Investec PLC Special Converting Shares;
“Investec PLC Special Voting Share”	as described in paragraph 2.5 of Annexure I;
“issuer-sponsored nominee programme”	the issuer-sponsored nominee programme to be offered to Inhold members and IGL members in terms of which Inhold members and IGL members who subscribe to such programme will be allocated their IGL ordinary shares and Investec PLC ordinary shares in a dematerialised form to be held by the nominee in accordance with the nominee terms and conditions;
“Joint Electorate Actions”	as described in paragraph 2.5 of Annexure I;
“JSE”	JSE Securities Exchange South Africa;
“Listings Requirements” or “JSE Listings Requirements”	the Listings Requirements of the JSE, BSE and NSX;

“Liquidation Event”	in relation to any person (the “Insolvent Party”), an order is made or an effective resolution is passed for winding-up of the Insolvent Party or a liquidator is appointed to the Insolvent Party;
“London Stock Exchange”	London Stock Exchange Plc;
“Matching Action”	in relation to an Action in respect of Investec PLC shareholders or IGL members (the “Initial Action”), an Action in respect of the shareholders in the other company in relation to which the Boards of Investec PLC and IGL resolve that it has as far as is practicable an economic effect on the shareholders of such other company equivalent, but not necessarily identical, to the economic effect of the Initial Action on the shareholders of the company undertaking the Initial Action;
“Matching Dividend”	as described in paragraph 7.2 of Annexure I;
“new IGL ordinary share certificates”	IGL ordinary share certificates to be issued pursuant to the implementation of the Inhold unbundling;
“new Investec PLC ordinary share certificates”	Investec PLC ordinary share certificates, to be issued pursuant to the implementation of the IGL unbundling and the IGL capital restructure;
“new Investec PLC ordinary shares”	Investec PLC ordinary shares to be issued pursuant to the proposed Investec PLC capital raising;
“nominee”	Computershare Nominees (Proprietary) Limited;
“nominee terms and conditions”	the terms and conditions set out in Annexure XVI to this circular;
“NSX”	the Namibian Stock Exchange;
“Office for Banks”	the Banks Supervisory Department of the South African Reserve Bank;
“Official List”	the official list maintained by the UK Listing Authority for the purposes of Part VI of FSMA;
“PLC operations”	IGL’s operations outside continental Southern Africa excluding GDM Finance (UK) Limited, The Global Investec Bond Limited, Investec Private Equity Management (Ireland) Limited, Investec Investment Management Ireland Limited, Nesa Ventures Inc., Investec International Holdings (Gibraltar) Limited, Investec Bank (Mauritius) Limited, Investec Finance Services (Indian Ocean) Limited, Vulcan Leasing Limited, Mineco Limited, Oreco Leasing Limited, Laroc Aviation Limited, Churchill Finance Services Two Limited, Churchill Finance Services Three Limited, Marvel Resources Limited, Investec International BV, Investec (Hong Kong) (Pty) Limited and Fedsure Investments (UK) Limited and its subsidiaries;
“pounds”, “pounds sterling” or “£”	the official currency of the United Kingdom;
“qualifying IGL members”	IGL members registered as such on the record date for the IGL unbundling;
“qualifying Inhold members”	Inhold members registered as such on the record date for the Inhold unbundling;
“Rand” or “R”	the official currency of South Africa;
“record date for the IGL capital restructure”	the date on which IGL members must be registered as such in order to participate in the IGL capital restructure, being 17:00 on Friday, 26 July 2002;
“record date for the Inhold unbundling”	the date on which Inhold members must be registered as such in order to participate in the Inhold distribution, being 17:00 on Thursday, 25 July 2002;
“record date for the IGL unbundling”	the date on which IGL members must be registered as such in order to participate in the IGL unbundling, being 17:00 on Friday, 26 July 2002;
“Restricted Jurisdiction”	any jurisdiction in respect of which the Investec PLC Board or the IGL Board (as the case may be) consider, in its absolute discretion, that the requirements of Applicable Regulation would mean that a transfer of Special Converting Shares to the shareholders entitled to such shares who are resident in that jurisdiction would be impracticable or unlawful;

“SA DAN Share”	as described in paragraph 7.4 of Annexure I;
“SA DAN Share Trust Deed”	the declaration of trust to be entered into between Investec PLC, IGL and SA Trust Co which sets out the parties' rights and obligations in relation to the SA DAN Share;
“SA DAS Share”	as described in paragraph 7.4 of Annexure I;
“SA DAS Share Trust Deed”	the declaration of trust to be entered into between Investec PLC, IGL and SA Trust Co which sets out the parties' rights and obligations in relation to the SA DAS Shares;
“SA GAAP”	generally accepted accounting principles in South Africa;
“SARB”	the South African Reserve Bank;
“SARS”	the South African Revenue Service;
“SA Trust Co”	the South African company established for the purpose of holding the SA DAN Share, the SA DAS Share and the IGL Special Converting Shares;
“SENS”	Stock Exchange News Service, a division of the JSE;
“shareholder” or “shareholders”	an Investec PLC shareholder or an IGL member or both (as the case may be);
“Sharing Agreement”	the DLC Structure Sharing Agreement entered into between Investec PLC and IGL;
“share statement”	a statement confirming ownership of electronic scrip in Inhold, IGL or Investec PLC, as the case may be, held on behalf of an Inhold member, an IGL member or an Investec PLC shareholder; respectively by a CSDP or broker;
“Significant Bank”	in relation to IGL, a bank registered under the Banks Act of South Africa (No. 94 of 1990) and, in relation to Investec PLC, an entity authorised by the FSA to accept deposits;
“South Africa” or “SA”	the Republic of South Africa;
“South African stamp duty”	the duty leviable in terms of item 15 of Schedule 1 to the Stamp Duties Act, 1968 (Act 77 of 1968), as amended;
“Southern Africa”	includes South Africa, Botswana, Namibia and Mauritius;
“Special Converting Shares”	as described in paragraph 2.7 of Annexure I;
“Special Converting Shares Trust Deeds”	the IGL Special Converting Shares Trust Deed and the Investec PLC Special Converting Shares Trust Deed;
“SRP”	the Securities Regulation Panel of South Africa established under the provisions of section 440B of the Act;
“SRP Code”	the code compiled by and the rules made by the SRP under Sections 440C(1), (3) and 440C(4) of the Act;
“STRATE”	Share TRANsactions Totally Electronic, the electronic settlement system used by the JSE;
“subsidiary”	in relation to: (a) IGL, a “subsidiary” has that term is defined in section 1(3) of the Act; and (b) Investec PLC, a “subsidiary” has that term is defined in section 736 of the UK Companies Act;
“suspensive conditions”	the suspensive conditions to the transactions as set out in paragraph 10 of this circular;
“Taxation Laws Amendment Act”	the South African Taxation Laws Amendment Act, 1994 (Act 20 of 1994), as amended;

“transactions”	collectively, the Inhold reorganisation, the Inhold unbundling, the Inhold delisting, the Inhold winding-up, the IGL reorganisation, the IGL internal restructure, the IGL capital restructure, the IGL unbundling, the implementation of the DLC Structure and the IGL name change and the proposed Investec PLC capital raising;
“transfer secretaries”	the registrars of IGL namely Computershare Investor Services Limited (registration number 1958/003546/06) in South Africa and The Transfer Secretaries (Proprietary) Limited (registration number 93/713) in Namibia and, in respect of Investec PLC, Computershare Investor Services PLC (registered number 3498808);
“Trust Company” or “Trust Companies”	SA Trust Co or UK Trust Co or both (as the context may require);
“Trust Corporation”	the independent trustee that holds all the issued shares in the Trust Companies who initially will be Mourant Holdings Limited;
“UK Companies Act”	the United Kingdom Companies Act 1985, as amended;
“UK City Code”	the UK City Code on Takeovers and Mergers;
“UK DAN Share”	as described in paragraph 7.4 of Annexure I;
“UK DAN Share Trust Deed”	the declaration of trust to be entered into between Investec PLC, IGL and UK Trust Co which sets out the parties’ rights and obligations in relation to the UK DAN Share;
“UK DAS Share”	as described in paragraph 7.4 of Annexure I;
“UK DAS Share Trust Deed”	the declaration of trust to be entered into between Investec PLC, IGL and UK Trust Co which sets out the parties’ rights and obligations in relation to the UK DAS Share;
“UK GAAP”	generally accepted accounting principles in the United Kingdom;
“UK Listing Authority” or “UKLA”	the Financial Services Authority in its capacity as competent authority under the Financial Services and Markets Act 2000;
“UK Listing Rules”	the Listing Rules made by the UK Listing Authority under Section 74(4) of FSMA;
“UK Takeover Panel”	the UK Panel on Takeovers and Mergers;
“UK Trust Co”	the UK company established for the purpose of holding the Investec PLC Special Voting Share, the UK DAN Share, the UK DAS Share and the Investec PLC Special Converting Shares;
“Unadjusted Action”	as described in paragraph 6.3 of Annexure I;
“unbundling legislation”	section 60 of the South African Income Tax Act, 1993 (Act 113 of 1993), as amended;
“United Kingdom” or “UK”	United Kingdom of Great Britain and Northern Ireland;
“US” or “United States”	the United States of America, its territories and possessions and the District of Columbia;
“VAT”	Value Added Tax; and
“Voting Agreement”	the agreement entered into between IGL, SA Trust Co, Investec PLC and UK Trust Co which sets out the parties’ rights and obligations in relation to the Investec PLC Special Voting Share and the voting rights attached to the IGL Special Converting Shares.



Investec

Holdings Limited

(Incorporated in the Republic of South Africa)
(Registration number: 1985/005574/06)
Share code on the JSE: INH ISIN code: ZAE000003562
("Inhold")

NOTICE OF GENERAL MEETING OF INHOLD MEMBERS

Notice is hereby given that a general meeting of Inhold members will be held in the Auditorium of Investec Bank Limited, Ground Floor, 100 Grayston Drive, Sandown, Sandton, 2196 at 09:00 on Friday, 12 July 2002, for the purpose of considering and, if deemed fit, passing, with or without modification, the following special and ordinary resolutions:

Special resolution number 1

"RESOLVED THAT:

In terms of section 62(1) of the Companies Act No 61 of 1973, as amended, the articles of association of Investec Holdings Limited ("Inhold") be and are hereby amended by the insertion of the following new article 113 after article 112:

"113. Fractions

Notwithstanding anything to the contrary contained in these articles in respect of fractions arising on implementation of any corporate action, such fractions will be rounded down to the nearest whole number if any fraction resulting is less than 0,5, or rounded up to the nearest whole number if any fraction resulting is equal to or greater than 0,5."

The reason for and effect of this special resolution number 1 is to amend the articles of association of Inhold to conform with the Corporate Action Rules of STRATE Limited.

Special resolution number 2

"RESOLVED THAT:

Subject to the passing and registration of special resolution number 1 set out in the notice convening the general meeting at which this special resolution number 2 will be considered and in terms of section 60 of the Income Tax Act, No. 113 of 1993, as amended, and articles 69 and 16.5 of the articles of association of Investec Holdings Limited ("Inhold") with effect from after the close of business (17:00) on the last day to trade in Inhold shares on the JSE Securities Exchange South Africa ("JSE"), in order to participate in the unbundling which is the subject of this special resolution number 2, which is expected to be on 18 July 2002 (which date is subject to change), Inhold hereby –

1. declares a dividend to the ordinary members of Inhold of an aggregate amount to be determined by the Board of Directors in Inhold out of Inhold's distributable reserves; and
2. in so far as Inhold's distributable reserves are insufficient to accommodate the unbundling which is the subject of this special resolution number 2, reduces its ordinary share capital and the share premium relating thereto by an aggregate amount to be determined by the Board of Directors of Inhold,

such dividend and capital reduction to be settled and discharged *in specie* by the distribution to the ordinary members of Inhold of 86.04 ordinary shares of R0.60 each in the share capital of Investec Group Limited for every 100 ordinary shares of R0.10 each in the share capital of Inhold registered in the name of an ordinary member in Inhold on the record date for the Inhold unbundling as defined in the circular to which the notice convening the general meeting at which this special resolution number 2 will be considered is attached (the "Record Date for the Inhold Unbundling"), (which date is subject to change). Where the distribution of the Investec Group Limited ordinary shares to any one or more ordinary member of Inhold is impractical and/or unlawful (such ordinary members hereinafter referred to as "Restricted Members") and the shares which are the subject of the prohibition (such shares hereinafter referred to as "Restricted Shares"), Inhold shall

procure that no Restricted Shares are delivered to Restricted Members and shall cause all Restricted Shares to be delivered to a trustee, which trustee shall hold the Restricted Shares in trust for Restricted Members in proportion to the Restricted Member's shareholding of ordinary shares in Inhold on the Record Date for the Inhold Unbundling; and shall dispose of the Restricted Shares on the JSE at market related prices, and pay the net proceeds, after deduction of all costs of such disposal or placement, to Restricted Members."

The reason for and effect of this special resolution number 2 is to authorise and effect the unbundling of the Investec Group Limited ordinary shares held by Inhold partially by way of a dividend in specie and partially by a capital reduction to be settled in specie.

Ordinary resolution number 1

"RESOLVED THAT:

Subject to the passing and registration of special resolution numbers 1 and 2 set out in the notice convening the general meeting at which this ordinary resolution number 1 will be considered and in terms of Rule 1.13 of the Listings Requirements of the JSE Securities Exchange South Africa ("JSE"), the directors of Investec Holdings Limited ("Inhold") be and are hereby authorised to make a request to the JSE for the termination of the JSE listing of the ordinary shares in Inhold with effect from the commencement of business (09:00) on the first business day following the date on which Inhold members must be registered as such in order to participate in the unbundling by Inhold of its holding of Investec Group Limited ordinary shares, which is to take place in terms of special resolution number 2 set out in the notice convening the general meeting at which this ordinary resolution number 1 will be considered, which date is excepted to be on 25 July 2002 (which date is subject to change)."

Special resolution number 3

"RESOLVED THAT:

Subject to the passing and, where applicable, registration of special resolution numbers 1 and 2 and ordinary resolution number 1 set out in the notice convening the general meeting at which this special resolution number 3 will be considered and in terms of sections 349 and 350 of the Companies Act No. 61 of 1973, as amended ("Companies Act"):

- 3.1 Investec Holdings Limited ("Inhold") be and is hereby placed in members' voluntary winding-up in terms of sections 349 and 350 of the Companies Act.
- 3.2 That Mr Norman Klein of Westrust (Proprietary) Limited be and is hereby appointed liquidator of Inhold ("the Liquidator").
- 3.3 The Liquidator shall not be required to furnish security to the Master of the High Court or to any other official in terms of section 375(1) of the Companies Act, or otherwise.
- 3.4 The remuneration of the Liquidator of R10,000 plus Value Added Tax, with any excess based on his customary professional fees on the basis of time spent on the liquidation, plus expenses plus Value Added Tax thereon, be authorised pursuant to section 384(1) of the Companies Act.
- 3.5 The Liquidator shall have all the powers conferred by the Companies Act including, specifically, those mentioned in section 386 of the Companies Act.
- 3.6 The Liquidator, without sanction of the High Court of South Africa, shall have and exercise all powers given by the Companies Act to a liquidator in a winding-up by Court.
- 3.7 Without prejudice to the generality of the powers hereby conferred on the Liquidator, the Liquidator shall be and is hereby authorised and empowered to –
 - 3.7.1 abandon or dispose of any secured asset of Inhold to the creditor holding security over such asset at an agreed value or at an amount to settle the claim with the creditor concerned;
 - 3.7.2 continue and prosecute to the final end or determination thereof, including any appeals, or to compromise, settle or adjust or to abandon any claim by or against Inhold as he in his discretion may deem fit in the best interest of Inhold; and/or
 - 3.7.3 engage the services of attorneys and counsel in connection with any matters arising out of or relating to the affairs of Inhold and to agree with such attorney and/or counsel the tariff and/or scale of fees to be charged and to pay such fees with or without taxation.
- 3.8 In terms of section 422(1)(b) of the Companies Act, the Liquidator shall be authorised, at his discretion, once Inhold has been finally wound-up and dissolved, to destroy all books, records, papers and other documents of Inhold.

3.9 The directors of Inhold shall not be required to furnish security in terms of the provisions of section 350(1)(b)(i) of the Companies Act and the directors shall lodge an affidavit confirming that to the best of their knowledge and belief Inhold has no debts in terms of section 350(1)(b)(ii)(aa) of the Companies Act and the auditors certify to the best of their knowledge and belief and in accordance with the books and records that Inhold has no debts in terms of section 350(1)(b)(ii)(bb).

3.10 The directors of Inhold be authorised pursuant to section 353(2)(b) of the Companies Act to exercise all the powers of Inhold subject to section 353(1) of the Companies Act, until the Liquidator informs Inhold that a certificate of appointment of liquidator has been duly issued by the Master of the High Court."

The reason for and effect of this special resolution number 3 is to provide for the members' voluntary winding-up of Inhold after the unbundling of the Investec Group Limited shares held by Inhold and the delisting of Inhold from the JSE Securities Exchange South Africa has been given effect to and to authorise the directors of Inhold and the Liquidator, as defined in this special resolution number 3, to attend to all matters incidental to the winding-up of Inhold.

Ordinary resolution number 2

"RESOLVED THAT:

Subject to the passing and, where applicable, registration of special resolution numbers 1, 2 and 3 and ordinary resolution number 1 set out in the notice convening the general meeting at which this ordinary resolution number 2 will be considered, the Liquidator; as defined in special resolution number 3 set out in the notice convening the general meeting at which this ordinary resolution number 2 will be considered, be authorised, if the amount of any cash that remains in Investec Holdings Limited ("Inhold") after the discharge of all liabilities of Inhold is such that in the Liquidator's opinion it would not be warranted to distribute same to the members of Inhold by reason of the small amount thereof and the costs involved in distributing same to the members, to pay such amount instead to a charitable organisation of the Liquidator's choice."

Ordinary resolution number 3

"RESOLVED THAT:

Subject to the passing and, where applicable, registration of ordinary resolution numbers 1 and 2 and special resolution numbers 1 and 2 set out in the notice convening the general meeting at which this ordinary resolution number 3 will be considered and in accordance with the requirements of the JSE Securities Exchange South Africa, the proposed capital raising by Investec PLC ("Investec PLC"), described in the circular to which the notice convening the general meeting at which this ordinary resolution number 3 is attached, of up to 10 000 000 ordinary shares in the share capital of Investec PLC on terms and conditions to be approved by the directors of Investec PLC, be and is hereby approved."

In order for ordinary resolution number 3 to be passed a 75% majority of the votes of all members present or represented by proxy at the general meeting excluding controlling shareholders, their associates and any party acting in concert, must be cast in favour of ordinary resolution number 3 to issue the new Investec PLC ordinary shares.

Ordinary resolution number 4

"RESOLVED THAT:

Subject to the passing and, where applicable, registration of special resolution numbers 1, 2 and 3 and ordinary resolution numbers 1, 2 and 3 set out in the notice convening the general meeting at which this ordinary resolution number 4 will be considered, any director or the company secretary of Investec Holdings Limited be and is hereby authorised to do all things and sign all documents which may be necessary to carry into effect the aforesaid resolutions."

Voting and proxies

Inhold members holding certificated Inhold ordinary shares Central Securities Depository Participants ("CSDP") who are unable to attend the general meeting of Inhold members, but wish to be represented thereat, should complete and return the form of proxy (blue), in accordance with the instructions contained therein, so as to be received at the office of the transfer secretaries, Computershare Investor Services Limited, 2nd Floor, Edura, 41 Fox Street, Johannesburg, 2001 (PO Box 61051, Marshalltown, 2107) by no later than 09:00 on Thursday, 11 July 2002.

Inhold members who have already dematerialised their Inhold ordinary shares through a Central Securities Depository Participants ("CSDP") or broker and who wish to attend the general meeting of Inhold members must instruct their CSDP or broker to issue them with the necessary authority to attend. Should Inhold members who have already dematerialised

their Inhold ordinary shares wish to vote by way of proxy, they must provide their CSDP or broker with their voting instructions in terms of the custody agreement entered into between them and their CSDP or broker; except for Inhold members who have elected "own name" registration in the sub-register through a CSDP or broker; which members must complete the form of proxy and return it in accordance with the instructions contained therein to the office of the transfer secretaries, Computershare Investor Services Limited, 2nd Floor, Edura, 41 Fox Street, Johannesburg, 2001 (PO Box 61051, Marshalltown, 2107) by no later than 09:00 on Thursday, 11 July 2002, or in terms of the custody agreement entered into between such dematerialised "own name" members and their CSDP or broker.

In respect of dematerialised Inhold ordinary shares, it is important to ensure that the person or entity (such as a nominee), whose name has been entered into the relevant sub-register maintained by a CSDP, completes the form of proxy in terms of which he appoints a proxy to vote at the general meeting of Inhold members in accordance with the instructions received from dematerialised beneficial holders.

A proxy need not also be an Inhold member.

On a show of hands every Inhold member present in person or represented by proxy shall have one vote and, on a poll, every Inhold member present in person or represented by proxy shall have one vote for every Inhold share held.

By order of the board

INVESTEC HOLDINGS LIMITED

Selwyn Noik

Company Secretary

Sandton

20 June 2002

Transfer secretaries

Computershare Investor Services Limited

2nd Floor, Edura

41 Fox Street

Johannesburg, 2001

(PO Box 61051, Marshalltown, 2107)



Investec

Holdings Limited

(Incorporated in the Republic of South Africa)
 (Registration number 1985/005574/06)
 Share code on the JSE: INH ISIN code: ZAE000003562
 ("Inhold")

FORM OF PROXY FOR THE GENERAL MEETING OF INHOLD MEMBERS

For use only by Inhold members holding certificated Inhold ordinary shares, nominee companies of Central Securities Depository Participants ("CSDP"), broker's nominee companies and Inhold members who have dematerialised their Inhold ordinary shares and who have elected "own name" registration, at the general meeting of members of Inhold, to be held at 09:00 on Friday, 12 July 2002, in the Auditorium of Investec Bank Limited, Ground Floor, 100 Grayston Drive, Sandown, Sandton, 2196.

Inhold members who have already dematerialised their Inhold ordinary shares through a CSDP or broker must not complete this form of proxy and must provide their CSDP or broker with their voting instructions, except for Inhold members who have elected "own name" registration in the sub-register through a CSDP or broker, which members must complete this form of proxy and lodge it with their CSDP or broker in terms of the custody agreement entered into between them and their CSDP or broker. Holders of dematerialised Inhold ordinary shares who have not elected "own name" registration and who wish to attend the Inhold general meeting must inform their CSDP or broker to issue them with the necessary authorisation to attend.

I/We (BLOCK LETTERS)

of

Telephone: (Work)

Telephone: (Home)

being the holder(s) of ordinary shares in Inhold, hereby appoint:

1. _____ or failing him/her;

2. _____ or failing him/her;

3. the chairman of the general meeting,

as my/our proxy to vote for me/us on my/our behalf at the general meeting of Inhold members to be held at 09:00 on Friday, 12 July 2002 and at every adjournment of that meeting.

Signed at _____ this _____ day of _____ 2002

Signature

Assisted by me (if applicable)

Please indicate with an "X" or the number of shares in the appropriate space below how you wish your votes to be cast. If you return this form duly signed, without any specific directions, the proxy shall be entitled to vote as he/she thinks fit.

	In favour of resolution	Against resolution	Abstain from voting
Special resolution number 1			
Special resolution number 2			
Ordinary resolution number 1			
Special resolution number 3			
Ordinary resolution number 2			
Ordinary resolution number 3			
Ordinary resolution number 4			

Please read the notes on the reverse side hereof.

Notes:

1. A certificated Inhold member and dematerialised "own name" Inhold member may insert the name(s) of one or more proxies (who need not be a member(s) of Inhold) in the space provided, with or without deleting the words "the chairman of the general meeting". The person whose name appears first on the form of proxy and has not been deleted and who is present at the general meeting will be entitled to act in priority to those whose names follow. In the event that no names are indicated, the proxy shall be exercised by the chairman of the general meeting.
2. A certificated Inhold member's or a dematerialised "own name" Inhold member's instructions to the proxy must be indicated by the insertion of an "X" or the relevant number of shares in the appropriate box provided. Failure to comply with the above will be deemed to authorise the proxy to vote as he/she thinks fit. However, where the proxy is the chairman, such failure shall be deemed to authorise the chairman to vote in favour of the relevant resolutions. A certificated Inhold member or a dematerialised "own name" Inhold member or his/her proxy is not obliged to use all the votes exercisable by the certificated Inhold member or dematerialised "own name" Inhold member or his/her proxy.
3. The completion and lodging of this form of proxy shall in no way preclude the certificated Inhold member or dematerialised "own name" Inhold member from attending, speaking and voting in person at the general meeting to the exclusion of any proxy appointed in terms hereof.
4. Should this form of proxy not be completed and/or received in accordance with these notes, the chairman may accept or reject it, provided, that in respect of its acceptance, he is satisfied as to the manner in which the certificated Inhold member or dematerialised "own name" Inhold member wishes to vote.
5. This form of proxy shall be valid for any adjournment of the general meeting as well as the meeting to which it relates, unless the contrary is stated hereon.
6. Where this form of proxy is signed under power of attorney, such power of attorney must accompany this form unless it has previously been registered with Inhold.
7. Where Inhold ordinary shares are held jointly, all joint holders are required to sign.
8. This form of proxy must be lodged at or posted to the transfer secretaries of Inhold, Computershare Investor Services Limited, 2nd Floor, Edura, 41 Fox Street, Johannesburg, 2001 (PO Box 61051, Marshalltown, 2107) so as to be received by not later than 09:00 on Thursday, 11 July 2002.



Investec

Group Limited

(Incorporated in the Republic of South Africa)
(Registration number 1925/002833/06)
Share code on the JSE: INT ISIN code: ZAE000012555
Share code on the NSX: IVC
Share code on the BSE: INV,BT
("IGL" or "the company")

NOTICE OF GENERAL MEETING OF IGL MEMBERS

Notice is hereby given that a general meeting of IGL members will be held in the Auditorium of Investec Bank Limited, Ground Floor, 100 Grayston Drive, Sandown, Sandton, 2196 at 09:30, or as soon thereafter as the general meeting of Investec Holdings Limited members is concluded, on Friday, 12 July 2002, for the purpose of considering and, if deemed fit, passing, with or without modification, the following special and ordinary resolutions:

Ordinary resolution number 1

"RESOLVED THAT:

In terms of section 228 of the Companies Act, No. 61 of 1973, as amended, the disposal by Investec Group Limited of all its operations outside continental Southern Africa, excluding GDM Finance (UK) Limited, The Global Investec Bond Ltd, Investec Private Equity Management (Ireland) Ltd, Investec Investment Management Ireland Ltd, Nesa Ventures Inc., Investec Finance Services (Indian Ocean) Ltd, Investec International Holdings (Gibraltar) Limited, Investec Bank (Mauritius) Limited, Vulcan Leasing Limited, Mineco Limited, Oreco Leasing Limited, Laroc Aviation Limited, Churchill Finance Services Two Limited, Churchill Finance Services Three Limited, Marvel Resources Ltd, Investec International BV, Investec (Hong Kong) (Pty) Ltd, and Fedsure Investments (UK) Ltd and its subsidiaries, to Investec PLC or subsidiaries of Investec PLC in terms of the to be signed/signed agreements tabled at the general meeting at which this ordinary resolution number 1 will be considered and copies of which specimen agreements have been initialled by the chairman of this general meeting for the purposes of identification, be and is hereby approved or, so far as necessary or as appropriate, be and is hereby ratified."

Special resolution number 1

"RESOLVED THAT:

Subject to the passing of ordinary resolution number 1 set out in the notice convening the general meeting at which this special resolution number 1 will be considered and in terms of section 55(1) and 62(1) of the Companies Act, No. 61 of 1973, as amended, the memorandum and the articles of association of Investec Group Limited be and are hereby replaced with a new memorandum and articles of association, copies of which have been tabled at the general meeting at which this special resolution number 1 will be considered and have been initialled by the chairman of the general meeting for the purposes of identification."

The reason for and effect of this special resolution number 1 is to replace IGL's current memorandum and articles of association with a new memorandum of association (updated in accordance with the resolutions set out in this notice of general meeting) and new articles of association, which are more reflective of the Dual Listed Companies Structure in which IGL will operate and which are updated in accordance with the resolutions set out in this notice of general meeting and with the recent amendments to the Companies Act, No. 61 of 1973, as amended, and the Listings Requirements of the JSE Securities Exchange South Africa.

Special resolution number 2

"RESOLVED THAT:

Subject to the passing and, where applicable, registration of ordinary resolution number 1 and special resolution number 1 set out in the notice convening the general meeting at which this special resolution number 2 will be considered and with effect from after the close of business (17:00) on the last day to trade, in order to participate in the capital restructure which is the subject of this special resolution number 2, which last day to trade is expected to be on 19 July 2002 (which date is subject to change):

- In terms of section 75(1)(e) of the Companies Act, No. 61 of 1973, as amended, and articles 8.1(c) of the articles of association of Investec Group Limited (“IGL”) adopted in terms of special resolution number 1 set out in notice convening the general meeting at which this special resolution number 2 will be considered, the 150 000 000 ordinary shares of R0.60 each in the authorised share capital of IGL and the 103 781 158 ordinary shares of R0.60 each in the issued share capital of IGL be and are hereby subdivided by a factor of 600: 1 into 90 000 000 000 ordinary shares of R0.001 each in the authorised share capital of IGL and 62 268 694 800 ordinary shares of R0.001 each in the issued share capital of IGL.
- In terms of article 10 of the articles of association of IGL, adopted in terms of special resolution number 1 set out in the notice convening the general meeting at which this special resolution number 2 will be considered, the share capital of IGL be and is hereby reduced by the cancellation of 62 230 295 772 issued ordinary shares of R0.001 each, without a distribution of capital to the members of IGL and with a concomitant transfer of the amount by which share capital is reduced to reserves, and the cancellation of 89 944 500 000 authorised ordinary shares of R0.001 each, with the effect that the authorised share capital of IGL will consist of 55 500 000 ordinary shares of R0.001 each and the issued share capital of IGL will consist of 38 399 028 ordinary shares of R0.001 each.”

The reason for and effect of this special resolution number 2 is to reduce the par value of the ordinary shares in the authorised and issued capital of IGL from R0.60 each to R0.001 each and to reduce each 100 ordinary shares in the authorised and issued share capital of IGL to 37 ordinary shares to facilitate the unbundling and subsequent listing of Investec PLC.

Special resolution number 3

“RESOLVED THAT:

Subject to the passing and, where applicable, registration of ordinary resolution number 1 and special resolution numbers 1 and 2 set out in the notice convening the general meeting at which this special resolution number 3 will be considered and in terms of section 75(1)(a) of the Companies Act, No. 61 of 1973, as amended, and article 7 of the articles of association of Investec Group Limited (“IGL”), adopted in terms of special resolution number 1 set out in the notice convening the general meeting at which this special resolution number 3 will be considered, with effect from the close of business (17:00) on the date on which IGL members must be registered as such in order to participate in the IGL distribution which is to take place in terms of special resolution number 4 set out in the notice convening the general meeting at which this special resolution number 3 will be considered, which date is expected to be on Friday, 26 July 2002 (which date is subject to change), the authorised share capital of IGL of R6 085 500 consisting of 55 500 000 ordinary shares of R0.001 each, 10 000 000 class “A” variable rate compulsory convertible non-cumulative preference shares of R0.60 each and 50 000 variable rate cumulative redeemable preference shares of R0.60 each, be and are hereby increased to a nominal value of R6 197 504 by the creation of –

- 1 Dividend Access (South African Resident) Redeemable Preference Share with a par value of R1.00, the rights and conditions attaching to which are set out in articles 5.1(a)(i), 5.1(b)(ii), 5.2, 6, 38.5(a) and 63.3 of the articles of association of IGL adopted in terms of special resolution number 1 set out in the notice convening the general meeting at which this special resolution number 3 will be considered;
- 1 Dividend Access (Non-South African Resident) Redeemable Preference Share with a par value of R1.00, the rights and conditions attaching to which are set out in articles 5.1(a)(i), 5.1(b)(ii), 5.2, 6, 38.5(a) and 63.3 of the articles of association of IGL adopted in terms of special resolution number 1 set out in the notice convening the general meeting at which this special resolution number 3 will be considered; and
- 112 000 000 Special Convertible Redeemable Preference Shares with a par value of R0.001 each, the rights and conditions attaching to which are set out in articles 4.5.1(a)(ii), 5.1(b)(i), 6, 34.4, 38.5(b), 57.4, 60, 61.3, 62.2, 62.3, 63.1, 63.2, 69.1 and 72 of the articles of association of IGL adopted in terms of special resolution number 1 set out in the notice convening the general meeting at which this special resolution number 3 will be considered.”

The reason for and effect of this special resolution number 3 is to increase IGL’s authorised ordinary share capital by the creation of 1 Dividend Access (South African Resident) Redeemable Preference Share (which has been defined as the SA DAS Share in the circular of which this notice of general meeting forms part), 1 Dividend Access (Non-South African Resident) Redeemable Preference Share (which has been defined as the SA DAN Share in the circular of which this notice of general meeting forms part) and 112 000 000 Special Convertible Redeemable Preference Shares (which have been defined as to IGL Special Converting Shares in the circular of which this notice of general meeting forms part) in order to facilitate the implementation of the Dual Listed Companies Structure.

Ordinary resolution number 2

“RESOLVED THAT:

Subject to the passing and, where applicable, registration of ordinary resolution number 1 and special resolution numbers 1, 2 and 3 set out in the notice convening the general meeting at which this ordinary resolution number 2 will be considered, the members of Investec Group Limited (“IGL”) approve the Dual Listed Companies (“DLC”) Structure

between IGL and Investec PLC, as described in the circular to which the notice convening the general meeting at which this ordinary resolution number 2 will be considered is attached, including, without limitation, the allotment and issue of a Dividend Access (South African Resident) Redeemable Preference Share, a Dividend Access (Non-South African Resident) Redeemable Preference Share and 70 633 746 Special Convertible Redeemable Preference Shares and the execution of, and compliance by IGL with the following agreements:

- the Sharing Agreement;
- the Voting Agreement;
- the UK DAS Share Trust Deed;
- the SA DAS Share Trust Deed;
- the UK DAN Share Trust Deed;
- the SA DAN Share Trust Deed;
- the Investec PLC Special Converting Shares Trust Deed; and
- the IGL Special Converting Shares Trust Deed,

in each case substantially in the form that has been available for inspection, submitted to the general meeting at which this ordinary resolution number 2 will be considered and initialled by the chairman of this general meeting for the purposes of identification, provided that the directors of IGL shall be and are hereby authorised to make such non-material modifications, variations, waivers, amendments and revisions as they in their absolute discretion think fit.”

Special resolution number 4

“RESOLVED THAT:

Subject to the passing and, where applicable, registration of ordinary resolution numbers 1 and 2 and special resolution numbers 1, 2 and 3 set out in the notice convening the general meeting at which this special resolution number 4 will be considered and in terms of section 60 of the Income Tax Act, No. 113 of 1993, as amended, and articles 120 and 10 of the adopted articles of association of Investec Group Limited (“IGL”) adopted in terms of special resolution number 1 set out in the notice convening the general meeting at which this special resolution number 4 will be considered, and with effect from after the close of business (17:00) on the last day to trade in IGL ordinary shares on the JSE Securities Exchange South Africa (“the JSE”) in order to participate in the IGL distribution which is to take place in terms of this special resolution number 4 which last day to trade is expected to be on 19 July 2002 (which date is subject to change), IGL hereby –

- declares a dividend to the ordinary members of IGL in an aggregate amount to be determined by the Board of Directors of IGL out of its distributable and non-distributable reserves; and

- reduces its share premium,

by an aggregate amount and in the proportion to be determined by the Board of Directors of IGL, such dividend and capital reduction to be settled and discharged *in specie* by the distribution to the ordinary members of IGL of 63 ordinary shares of £0.001 (one thousandth of a Pound) each in the share capital of Investec PLC for every 37 ordinary shares of R0.001 each in the share capital of IGL held by an ordinary member in IGL on the record date as defined in the circular to which the notice convening the general meeting at which this special resolution number 4 will be considered is attached, (“the Record Date for the IGL Unbundling”), provided that where distribution of the Investec PLC ordinary shares to any one or more ordinary members of IGL is impractical and/or unlawful (such members hereinafter referred to as “Restricted Members”) and the shares which are the subject of the prohibition (such shares hereinafter referred to as “Restricted Shares”), IGL shall procure that no Restricted Shares are delivered to Restricted Members and shall cause all Restricted Shares to be delivered to a trustee, which trustee shall hold the Restricted Shares in trust for Restricted Members in proportion to the Restricted Members’ shareholding of ordinary shares in IGL on the Record Date for the IGL Unbundling; and shall dispose of the Restricted Shares on the JSE at market related prices, and pay the net proceeds, after deduction of all costs of such disposal or placement, to Restricted Members.”

The reason for and effect of this special resolution number 4 is to authorise and effect the unbundling by IGL of Investec PLC ordinary shares partially by way of a dividend in specie and partially by a capital reduction to be settled in specie.

Ordinary resolution number 3

“RESOLVED THAT:

Subject to the passing and, where applicable, registration of ordinary resolution numbers 1 and 2 and special resolution numbers 1, 2, 3 and 4 set out in the notice convening the general meeting at which this ordinary resolution number 3 will be considered and in terms of the Listings Requirements of the JSE Securities Exchange South Africa, Investec Group Limited (“IGL”), and hereby ratifies and/or adopts, as may be appropriate, all share schemes relating to IGL, and hereby ratifies and/or approves, as will be appropriate, all share schemes relating to Investec PLC which share schemes are all referred to in the circular to which the notice convening the general meeting at which this ordinary resolution number 3 will be considered is attached, tabled at the general meeting at which this ordinary resolution number 3 will be considered and which have been initialled by the chairman of this general meeting for the purposes of identification.”

Ordinary resolution number 4

“RESOLVED THAT:

Subject to the passing and, where applicable, registration of ordinary resolution numbers 1, 2 and 3 and special resolution numbers 1, 2, 3 and 4 set out in the notice convening the general meeting at which this ordinary resolution number 4 will be considered all classes of unissued shares in the authorised share capital of Investec Group Limited (“IGL”), be and are hereby placed under the control of the directors of IGL who are authorised to allot and issue the same at their discretion until the next annual general meeting of IGL subject to the provisions of the Companies Act, No. 61 of 1973, as amended, and the Listings Requirements of the JSE Securities Exchange South Africa.”

Ordinary resolution number 5

“RESOLVED THAT:

Subject to the passing and, where applicable, registration of ordinary resolution numbers 1, 2, 3 and 4 and special resolution numbers 1, 2, 3 and 4 set out in the notice convening the general meeting at which this ordinary resolution number 5 will be considered and the Listings Requirements of the JSE Securities Exchange South Africa, the directors of Investec Group Limited (“IGL”) be and they are hereby authorised to allot and issue ordinary shares of R0.001 each for cash as and when suitable situations arise, subject to the Companies Act, No. 61 of 1973, as amended, and subject to the following limitations –

1. this authority shall not extend beyond 15 months from the date of this general meeting;
2. a paid press announcement giving full details including the impact on net asset value and earnings per share, will be published at the time of an issue representing, on a cumulative basis within 1 financial year, 5% or more of the number of shares in issue prior to such issue;
3. that issues in the aggregate in any one financial year will not exceed 15% of the number of ordinary shares in issue, including instruments which are compulsorily convertible;
4. that, in determining the price at which an allotment and issue of shares may be made in terms of this authority, the maximum discount permitted will be 10% of the weighted average ruling price of the shares in question as determined over the 30 days prior to the date of announcement or where no announcement is made, the date of allotment and issue of the shares.”

In order for ordinary resolution number 5 to be passed a 75% majority of the votes of all members present or represented by proxy at the general meeting excluding controlling shareholders, their associates and any party acting in concert, must be cast in favour of the ordinary resolution number to issue the new Investec PLC ordinary shares.

Ordinary resolution number 6

“RESOLVED THAT:

Subject to the passing and, where applicable, registration of ordinary resolution numbers 1, 2, 3, 4 and 5 and special resolution numbers 1, 2, 3 and 4 set out in the notice convening the general meeting at which this ordinary resolution number 6 will be considered and in accordance with the requirements of the JSE Securities Exchange South Africa, the proposed capital raising by Investec PLC (“Investec PLC”), described in the circular to which the notice convening the general meeting at which this ordinary resolution number 6 is attached, of up to 10 000 000 ordinary shares in the share capital of Investec PLC on terms and conditions to be approved by the directors of Investec PLC, be and is hereby approved.”

In order for ordinary resolution number 6 to be passed a 75% majority of the votes of all members present or represented by proxy at the general meeting excluding controlling shareholders, their associates and any party acting in concert, must be cast in favour of ordinary resolution number 6 to issue the new Investec PLC ordinary shares.

Special resolution number 5

“RESOLVED THAT:

Subject to the passing and, where applicable, registration of ordinary resolution numbers 1, 2, 3, 4, 5 and 6 and special resolution numbers 1, 2, 3 and 4 set out in the notice convening the general meeting at which this special resolution number 5 will be considered and in terms of section 44(1)(a) of the Companies Act, No. 61 of 1973, as amended, and with effect from the commencement of business (09:00) on the first business day following the last day on which Investec Group Limited (“IGL”) members can trade in IGL ordinary shares on the JSE in order to participate in the IGL distribution which is to take place in terms of special resolution number 4 set out in the notice convening the general meeting at which this special resolution number 5 will be considered, which last day to trade is expected to be on 19 July 2002 (which date is subject to change), the name of Investec Group Limited be and is hereby changed to Investec Limited.”

The reason for and effect of this special resolution number 5 is to change the name of IGL to Investec Limited in order to align the name of IGL with that of Investec PLC, the company with whom it is tied in the Dual Listed Companies structure.

Ordinary resolution number 7

“RESOLVED THAT:

Subject to the passing and, where applicable, registration of ordinary resolution numbers 1, 2, 3, 4, 5 and 6 and special resolution numbers 1, 2, 3, 4 and 5 set out in the notice convening the general meeting at which this ordinary resolution number 7 will be considered, any director or the company secretary of Investec Group Limited (whose name will be changed to Investec Limited in terms of special resolution number 5 set out in the notice convening the general meeting at which this ordinary resolution number 7 will be considered) be and is hereby authorised to do all things and sign all documents which may be necessary to carry into effect the aforesaid resolutions.”

Voting and proxies

IGL members holding certificated IGL ordinary shares who are unable to attend the general meeting of IGL members, but wish to be represented thereat, should complete and return the form of proxy (yellow), in accordance with the instructions contained therein, so as to be received at the office of the transfer secretaries, in respect of holdings of IGL ordinary shares that are listed on the JSE and BSE, Computershare Investor Services Limited, 2nd Floor, Edura, 41 Fox Street, Johannesburg, 2001 (PO Box 61051, Marshalltown, 2107) or, in respect of holdings of IGL ordinary shares that are listed on the NSX, The Transfer Secretaries (Proprietary) Limited, Shop 12, Kaiserkrone Centre, Post Street Mall, Windhoek, Namibia (PO Box 2401, Windhoek, Namibia) by no later than 09:00 on Thursday, 11 July 2002.

IGL members who have already dematerialised their IGL ordinary shares through a Central Securities Depository Participant (“CSDP”) or broker and who wish to attend the general meeting of IGL members must instruct their CSDP or broker to issue them with the necessary authority to attend. Should IGL members who have already dematerialised their IGL ordinary shares wish to vote by way of proxy, they must provide their CSDP or broker with their voting instructions in terms of the custody agreement entered into between them and their CSDP or broker, except for IGL members who have elected “own name” registration in the sub-register through a CSDP or broker, which members must complete the form of proxy and return it in accordance with the instructions contained therein to the office of the transfer secretaries, in respect of holdings of IGL ordinary shares listed on the JSE and BSE, Computershare Investor Services Limited, 2nd Floor, Edura, 41 Fox Street, Johannesburg, 2001 (PO Box 61051, Marshalltown, 2107) or, in respect of holdings of IGL ordinary shares listed on the NSX, The Transfer Secretaries (Proprietary) Limited, Shop 12, Kaiserkrone Centre, Post Street Mall, Windhoek, Namibia (PO Box 2401, Windhoek, Namibia) by no later than 09:30 on Thursday, 11 July 2002 or in terms of the custody agreement entered into between such dematerialised “own name” members and their CSDP.

On a show of hands every IGL member present in person or represented by proxy shall have one vote and, on a poll, every IGL member present in person or represented by proxy shall have one vote for every IGL ordinary share held.

A proxy need not also be an IGL member.

By order of the board

INVESTEC GROUP LIMITED

Selwyn Noik

Company Secretary

Sandton
20 June 2002

Transfer secretaries

Computershare Investor Services Limited
2nd Floor, Edura
41 Fox Street
Johannesburg, 2001
(PO Box 61051, Marshalltown, 2107)

or

The Transfer Secretaries (Proprietary) Limited
Shop 12, Kaiserkrone Centre
Post Street Mall
Windhoek, Namibia
(PO Box 2401, Windhoek, Namibia)



Investec

Group Limited

(Incorporated in the Republic of South Africa)
(Registration number 1925/002833/06)
Share code on the JSE: INT ISIN code: ZAE000012555
Share code on the NSX: IVC
Share code on the BSE: INV.BT
("IGL" or "the company")

FORM OF PROXY FOR THE GENERAL MEETING OF IGL MEMBERS

For use only by IGL members holding certificated IGL ordinary shares and class "A" variable rate compulsory convertible non-cumulative preference shares in the company, nominee companies of Central Securities Depository Participants ("CSDP"), broker's nominee companies and IGL members who have dematerialised their IGL ordinary shares and who have elected "own name" registration at the general meeting of IGL members, to be held at 09:30, or as soon thereafter as the general meeting of Investec Holdings Limited ("Inhold") members (to be held at 09:00 on Friday, 12 July 2002) is concluded, on Friday, 12 July 2002, in the Auditorium of Investec Bank Limited, Ground Floor, 100 Grayston Drive, Sandown, Sandton, 2196.

IGL members who have already dematerialised their IGL ordinary shares through a CSDP or broker must not complete this form or proxy and must provide their CSDP or broker with their voting instructions, except for IGL members who have elected "own name" registration in the sub-register through a CSDP or broker; which members must complete this form of proxy and lodge it with their CSDP or broker in terms of the custody agreement entered into between them and their CSDP or broker. Holders of dematerialised IGL ordinary shares who have not elected "own name" registration and who wish to attend the general meeting of IGL members must inform their CSDP or broker to issue them with the necessary authorisation to attend.

I/We (BLOCK LETTERS)

of

Telephone: (Work)

Telephone: (Home)

being the holder(s) of ordinary shares in IGL; and/or

the holder(s) of class "A" variable rate compulsory convertible non-cumulative preference shares in the company

hereby appoint:

1. _____ or failing him/her,

2. _____ or failing him/her,

3. the chairman of the general meeting,

as my/our proxy to vote for me/us on my/our behalf at the general meeting of IGL members to be held at 09:30, or as soon thereafter as the general meeting of Inhold members is concluded, on Friday, 12 July 2002 and at every adjournment of that meeting.

Signed at _____ this _____ day of _____ 2002

Signature _____

Assisted by me (if applicable) _____

Please indicate with an "X" or the number of shares in the appropriate space below how you wish your votes to be cast. If you return this form duly signed, without any specific directions, the proxy shall be entitled to vote as he/she thinks fit.

	In favour of resolution	Against resolution	Abstain from voting
Ordinary resolution number 1			
Special resolution number 1			
Special resolution number 2			
Special resolution number 3			
Ordinary resolution number 2			
Special resolution number 4			
Ordinary resolution number 3			
Ordinary resolution number 4			
Ordinary resolution number 5			
Ordinary resolution number 6			
Special resolution number 5			
Ordinary resolution number 7			

Please read the notes on the reverse side hereof.

Notes:

1. A certificated IGL member or a dematerialised "own name" IGL member may insert the name(s) of one or more proxies (who need not be a member(s) of the company) in the space provided, with or without deleting the words "the chairman of the general meeting". The person whose name appears first on the form of proxy and has not been deleted and who is present at the general meeting will be entitled to act in priority to those whose names follow. In the event that no names are indicated, the proxy shall be exercised by the chairman of the general meeting.
2. A certificated IGL member's or a dematerialised "own name" IGL member's instructions to the proxy must be indicated by the insertion of an "X" or the relevant number of shares in the appropriate box provided. Failure to comply with the above will be deemed to authorise the proxy to vote as he/she thinks fit. However, where the proxy is the chairman, such failure shall be deemed to authorise the chairman to vote in favour of the relevant resolutions. A certificated IGL member or a dematerialised "own name" IGL member or his/her proxy is not obliged to use all the votes exercisable by the certificated IGL member or his/her proxy.
3. The completion and lodging of this form of proxy shall in no way preclude the certificated IGL member or the dematerialised "own name" IGL member from attending, speaking and voting in person at the general meeting to the exclusion of any proxy appointed in terms hereof.
4. Should this form of proxy not be completed and/or received in accordance with these notes, the chairman may accept or reject it, provided, that in respect of its acceptance, he is satisfied as to the manner in which the certificated IGL member or the dematerialised "own name" IGL member wishes to vote.
5. This form of proxy shall be valid for any adjournment of the general meeting as well as the meeting to which it relates, unless the contrary is stated hereon.
6. Where this form of proxy is signed under power of attorney, such power of attorney must accompany this form unless it has previously been registered with IGL.
7. Where IGL ordinary shares or the IGL compulsory convertible non-cumulative preference shares are held jointly, all joint holders are required to sign.
8. This form of proxy must be lodged at or posted to the transfer secretaries of the company, in respect of holdings of IGL ordinary shares that are listed on the JSE Securities Exchange South Africa or the Botswana Stock Exchange, Computershare Investor Services Limited, 2nd Floor, Edura, 41 Fox Street, Johannesburg, 2001 (PO Box 61051, Marshalltown, 2107) or; in respect of holdings of IGL ordinary shares that are listed on the Namibian Stock Exchange, The Transfer Secretaries (Proprietary) Limited, Shop 12, Kaiserkrone Centre, Post Street Mall, Windhoek, Namibia (PO Box 2401, Windhoek, Namibia) so as to be received by not later than 09:30 on Thursday, 11 July 2002.

FORM OF SURRENDER FOR USE BY CERTIFICATED INHOLD MEMBERS ONLY IN RESPECT OF THEIR ENTITLEMENT TO INVESTEC GROUP LIMITED ("IGL") ORDINARY SHARES AND INVESTEC PLC ("INVESTEC PLC") ORDINARY SHARES

1. Inhold members who wish to participate in the issuer-sponsored nominee programme and who are eligible to do so should, after reading, understanding and agreeing to be bound by the terms and conditions relating to the issuer-sponsored nominee programme (detailed in Annexure XVI of the circular of which this form of surrender forms part) and the Custody Service (detailed in Annexure XVII of the circular of which this form of surrender forms part) tick [✓] box [C(i)] to clearly indicated their instruction as to the registration of their uncertificated IGL ordinary shares and uncertificated Investec PLC ordinary shares and send this form, together with their Inhold share certificate(s) and/or other documents of title, to Computershare Investor Services Limited, 2nd Floor, Edura House, 41 Fox Street, Johannesburg, 2001 (PO Box 61051, Marshalltown, 2107).
2. Inhold members who wish to appoint Computershare Custodial Services Limited as their CSDP and wish to have their uncertificated IGL ordinary shares and uncertificated Investec PLC ordinary shares held in their own name in the sub-register of members held by Computershare Custodial Services Limited and who are eligible to do so should, after reading, understanding and agreeing to be bound by the terms and conditions relating to the Custody Service (detailed in Annexure XVII of the circular of which this form of surrender forms part) tick [✓] box [C(ii)] to clearly indicate their instruction and send this form, together with their Inhold share certificate(s) and/or other documents of title, to Computershare Investor Services Limited, 2nd Floor, Edura, 41 Fox Street, Johannesburg, 2001 (PO Box 61051, Marshalltown, 2107).
3. Inhold members who wish to receive a new IGL share certificate and new Investec PLC share certificate should tick [✓] box [C(iii)] and send this form, together with their Inhold share certificate(s) and/or other documents of title, to Computershare Investor Services Limited, 2nd Floor, Edura, 41 Fox Street, Johannesburg, 2001.

The attention of Inhold members is drawn to the fact that those Inhold members who elect to receive a new IGL share certificate and new Investec PLC share certificate will be required to dematerialise such share certificates in order to trade their IGL ordinary shares and Investec PLC ordinary shares on the JSE Securities Exchange South Africa ("JSE"). The dematerialisation process can take between 24 hours and 10 days depending on the volumes being processed by STRATE at the time of the dematerialisation.

Inhold members should surrender their Inhold share certificate(s) by no later than 17:00 on Thursday, 25 July 2002 and failure to do so will result in their Inhold ordinary shares no longer being good for delivery in respect of transactions entered into on the JSE on or after the close of business (17:00) on Thursday, 25 July 2002.

C: PLEASE TICK [√] THE BOX WITH THE APPROPRIATE INSTRUCTION

(i)

I/We agree to hold my/our IGL ordinary shares and Investec PLC ordinary shares under the issuer-sponsored nominee programme offered by such issuers and administered by Computershare Custodial Services Limited in accordance with the nominee terms and conditions. I/We consent to my/our shares being transferred to Computershare Nominees (Proprietary) Limited to be held on my/our behalf under the issuer-sponsored nominee programme and instruct Computershare Custodial Services Limited to give effect to this instruction. I/We further agree to appoint Computershare Custodial Services Limited as my/our CSDP. **(Please note that this option is only available to private investors who are not non-resident or emigrant holders of Inhold ordinary shares for purposes of the South African Exchange Control Regulation.)**

OR

(ii)

I/We do not wish to hold my/our shares under the issuer-sponsored nominee programme and wish to hold my/our uncertificated IGL ordinary shares and uncertificated Investec PLC ordinary shares in my own name in the sub-register maintained by Computershare Custodial Services Limited in accordance with the custody terms and conditions. I/We agree to pay the applicable custody and service fees to Computershare Custodial Services Limited as set out in the custody terms and conditions:

Name of stockbroker: _____ Contact number (including area code): _____

OR

(iii)

I/We wish to receive a share certificate in respect of my/our entitlement to IGL ordinary shares and Investec PLC ordinary shares.

D: ISSUER COMMUNICATION SELECTION (This section must only be completed if you elected option C(i) or C(ii))

[√] (TICK THE APPLICABLE BOX)

I/We wish to receive an annual report for securities maintained in terms of this custody mandate.

I/We do not wish to receive an annual report for securities maintained in terms of this security mandate.

If available, I/We wish to receive annual reports and other documentation in electronic format.

I/We, the undersigned person(s) indicated in Part A above have read this entire election and surrender form (and if the election made in C(i) or C(ii) above has been made have read the nominee terms and conditions and the custody terms and conditions to which this form is attached and agree to be bound by the election made by me/us.

E: APPLICABLE TO NON-RESIDENT INHOLD MEMBERS ONLY

I.1 Non-residents who are emigrants from the Republic of South Africa (“South Africa”)

New IGL shares certificates and new Investec PLC share certificates and share statements will be sent to the authorised dealer in foreign exchange in South Africa controlling such shareholders' blocked assets and will be restrictively endorsed in terms of the South African Exchange Control Regulations. Such non-residents must give the following information:

Name and address of authorised dealer in South Africa _____

Account number _____

In respect of the Investec PLC ordinary shares due to them, the attention of non-residents is drawn to the provisions of paragraph 8.5(b) of the circular of which this form of surrender forms part.

1.2 All other non-residents

New IGL share certificates and share statements will be sent to the registered address of the non-resident concerned or any other address in accordance with the posting instructions given on the face of this form and will be restrictively endorsed in terms of the South African Exchange Control Regulations. The new Investec PLC share certificates or share statements will, in accordance with paragraph 4.7.2.7 of the circular of which this form of surrender forms part, be posted by registered post, at the risk of the member, to the address set out in the register, on or about Monday, 29 July 2002.

Name and address of authorised dealer in South Africa

Account number

Dated at _____ this day of _____ 2002

Signature _____

Note:

A share statement reflecting the IGL ordinary shares and Investec PLC ordinary shares held on your behalf in the issuer-sponsored nominee programme or in custody in your own name with Computershare Custodial Services Limited or new IGL share certificates and new Investec PLC share certificates, as the case may be, will be posted by ordinary post on Monday, 29 July 2002 if such documents of title are received before the close of business (17:00) on Thursday, 25 July 2002, or within five business days of receipt of the existing documents of title, if received after the close of business (17:00) on Thursday, 25 July 2002.

FORM OF SURRENDER FOR USE BY CERTIFICATED IGL MEMBERS ONLY IN RESPECT OF THEIR IGL ORDINARY SHARES AND THEIR ENTITLEMENT TO INVESTEC PLC ("INVESTEC PLC") ORDINARY SHARES

1. IGL members who wish to participate in the issuer-sponsored nominee programme and who are eligible to do so, should, after reading, understanding and agreeing to be bound by the terms and conditions relating to the issuer-sponsored nominee programme (detailed in Annexure XVI of the circular of which this form of surrender forms part) and the Custody Service (detailed in Annexure XVII of the circular of which this form of surrender forms part) tick box [C(i)] to clearly indicate their instruction as to the registration of their uncertificated IGL ordinary shares and uncertificated Investec PLC ordinary shares and send this form, together with their IGL share certificate(s) and/or other documents of title to, in respect of holdings of IGL ordinary shares listed on the JSE Securities Exchange South Africa ("the JSE") or the Botswana Stock Exchange, ("BSE") Computershare Investor Services Limited, 2nd Floor, Edura, 41 Fox Street, Johannesburg, 2001 (PO Box 61051, Marshalltown, 2107) or, in respect of holdings of IGL ordinary shares listed on the Namibian Stock Exchange ("NSX") to The Transfer Secretaries (Proprietary) Limited, Shop 12, Kaiserkrone Centre, Post Street Mall, Windhoek, Namibia (PO Box 2401, Windhoek, Namibia).
2. IGL members who wish to appoint Computershare Custodial Services Limited as their CSDP and wish to have their uncertificated IGL ordinary shares and uncertificated Investec PLC ordinary shares held in their own name in the sub-register of members held by Computershare Custodial Services Limited and who are eligible to do so should, after reading, understanding and agreeing to be bound by the terms and conditions relating to the Custody Service (detailed in Annexure XVII of the circular of which this form of surrender forms part) tick box (C(ii)) to clearly indicate their instruction and send this form together with their IGL share certificate(s) and/or other documents of title, to in respect of holdings of IGL ordinary shares listed on the JSE or the BSE, Computershare Investor Services Limited, 2nd Floor, Edura, 41 Fox Street, Johannesburg, 2001 (PO Box 61051, Marshalltown, 2107) or, in respect of holdings of IGL ordinary shares listed on the NSX to The Transfer Secretaries (Proprietary) Limited, Shop 12, Kaiserkrone Centre, Post Street Mall, Windhoek, Namibia (PO Box 2401, Windhoek, Namibia).
3. IGL members who wish to receive a new IGL share certificate and new Investec PLC share certificate should tick box (C(iii)) and send this form together with their IGL share certificate(s) and/or other documents of title, to Computershare Services Limited, 2nd Floor, Edura, 41 Fox Street, Johannesburg, 2001.

The attention of IGL members is drawn to the fact that those IGL members who elect to receive a new IGL share certificate and new Investec PLC share certificate will be required to dematerialise such share certificates in order to trade their IGL ordinary shares and Investec PLC ordinary shares on the JSE. The dematerialisation process can take between 24 hours and 10 days depending on the volumes being processed by STRATE at the time of the dematerialisation.

IGL members should surrender their Inhold share certificate(s) by no later than 16:00 on Friday, 26 July 2002 and failure to do so will result in their IGL ordinary shares no longer being good for delivery in respect of transactions entered into on the JSE on or after the close of business (17:00) on Friday, 26 July 2002.

C: PLEASE TICK [√] THE BOX WITH THE APPROPRIATE INSTRUCTION

(i)

I/We agree to hold my/our IGL ordinary shares and Investec PLC ordinary shares under the issuer-sponsored nominee programme offered by such issuers and administered by Computershare Custodial Services Limited in accordance with the nominee terms and conditions. I/We consent to my/our shares being transferred to Computershare Nominees (Proprietary) Limited to be held on my/our behalf under the issuer-sponsored nominee programme and instruct Computershare Custodial Services Limited to give effect to this instruction. I/We further agree to appoint Computershare Custodial Services Limited as my/our CSDP. **(Please note that this option is only available to private investors who are not non-resident or emigrant holders of IGL ordinary shares for purposes of the South African Exchange Control Regulation.)**

OR

(ii)

I/We do not wish to hold my/our shares under the issuer-sponsored nominee programme and wish to hold my/our uncertificated IGL ordinary shares and uncertificated Investec PLC ordinary shares in my own name in the sub-register maintained by Computershare Custodial Services Limited in accordance with the custody terms and conditions. I/We agree to pay the applicable custody and service fees to Computershare Custodial Services Limited as set out in the custody terms and conditions:

Name of stockbroker: _____

Contact number (including area code): _____

OR

(iii)

I/We wish to receive a share certificate in respect of my/our entitlement to IGL ordinary shares and Investec PLC ordinary shares.

D: ISSUER COMMUNICATION SELECTION (This section must only be completed if you elected option C(i) or C(ii))

[√] (TICK THE APPLICABLE BOX)

I/We wish to receive an annual report for securities maintained in terms of this custody mandate.

I/We do not wish to receive an annual report for securities maintained in terms of this security mandate.

If available, I/We wish to receive annual reports and other documentation in electronic format.

I/We, the undersigned person(s) indicated in Part A above have read this entire election and surrender form (and if the election made in [C(i) or C(ii)] above has been made have read the nominee terms and conditions and the custody terms and conditions to which this form is attached and agree to be bound by the election made by me/us.

E: APPLICABLE TO NON-RESIDENT IGL MEMBERS ONLY

I.1 Non-residents who are emigrants from the Republic of South Africa (“South Africa”)

New IGL shares certificates and new Investec PLC share certificates and share statements will be sent to the authorised dealer in foreign exchange in South Africa controlling such shareholders' blocked assets and will be restrictively endorsed in terms of the South African Exchange Control Regulations. Such non-residents must give the following information:

Name and address of authorised dealer in South Africa

Account number

In respect of the Investec PLC ordinary shares due to them, the attention of non-residents is drawn to the provisions of paragraph 8.5(b) of the circular of which this form of surrender forms part.

1.2 All other non-residents

New IGL share certificates and share statements will be sent to the registered address of the non-resident concerned or any other address in accordance with the posting instructions given on the face of this form and will be restrictively endorsed in terms of the South African Exchange Control Regulations. The new Investec PLC share certificates or share statements will, in accordance with paragraph 4.7.2.7 of the circular of which this form of surrender forms part, where applicable, be posted by registered post, at the risk of the member, to the address set out in the register of members, on or about Monday, 29 July 2002.

Name and address of authorised dealer in South Africa

Account number

Dated at _____ this day of _____ 2002

Signature _____

Note:

A share statement reflecting the IGL ordinary shares and Investec PLC ordinary shares held on your behalf in the issuer-sponsored nominee programme or in custody in your own name with Computershare Custodial or new IGL share certificates and new Investec PLC share certificates, as the case may be, will be posted by ordinary post on Monday, 29 July 2002 if such documents of title are received before the close of business (17:00) on Friday, 26 July 2002, or within five business days of receipt of the existing documents of title, if received after the close of business (17:00) on Friday, 26 July 2002.

